

**CM Synchronous Servomotors**

**Edition**

*12/2007*



**Operating Instructions**

10566112 / US

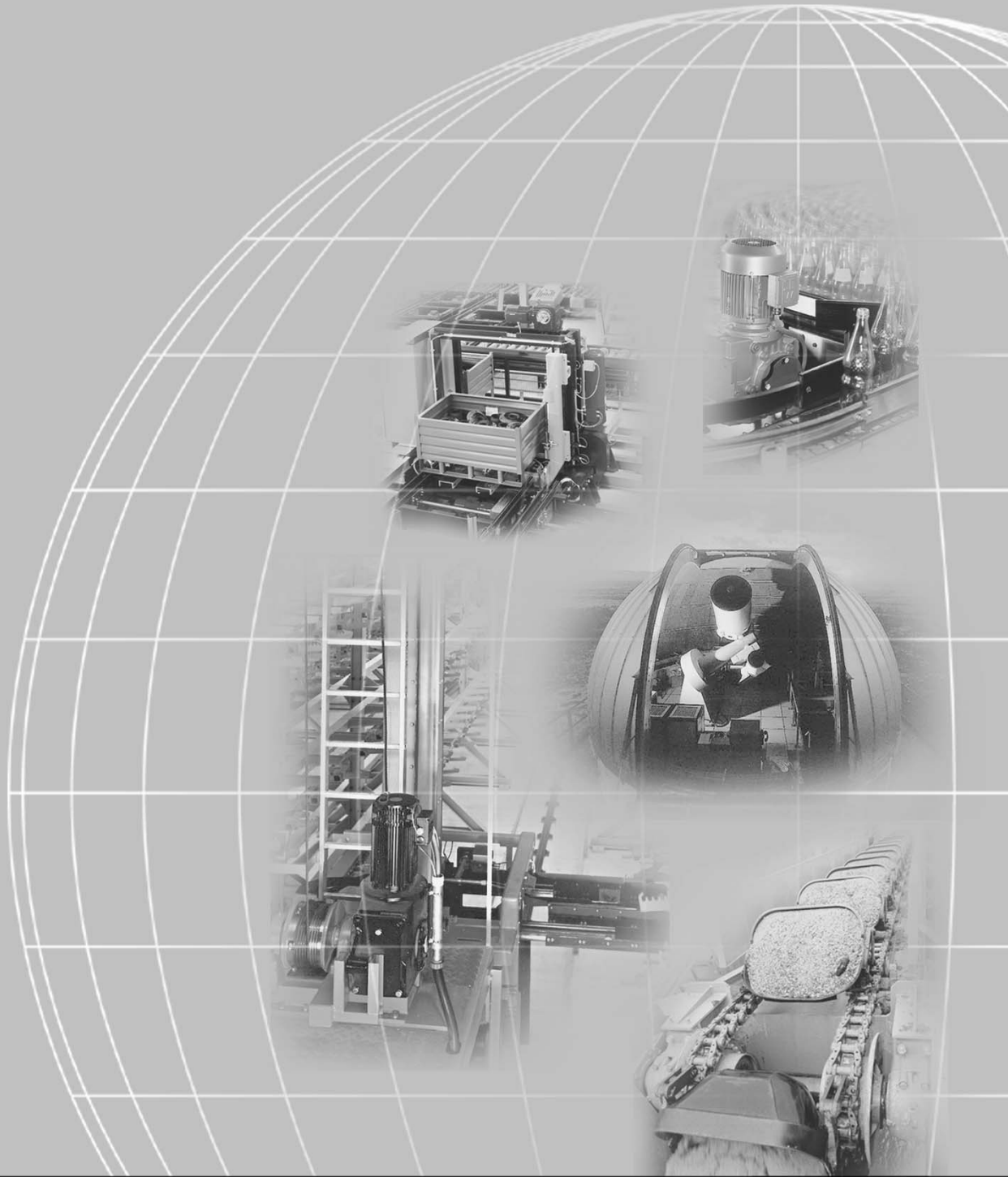

## SEW-EURODRIVE

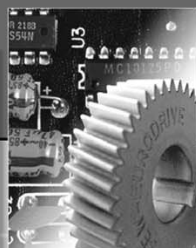



**1 Important Notes..... 4**



**2 Safety Notes ..... 5**



**3 Motor Design ..... 6**

3.1 Basic design of CM synchronous servomotor..... 6  
3.2 Nameplate, type designation ..... 7



**4 Mechanical Installation..... 8**

4.1 Required tools / resources ..... 8  
4.2 Before you begin..... 8  
4.3 Preliminary work ..... 8  
4.4 Installing the motor..... 10  
4.5 Installation tolerances ..... 10



**5 Electrical Installation ..... 11**

5.1 Wiring notes ..... 11  
5.2 Connecting motor and encoder system via SM.. / SB.. plug connector.. 12  
5.3 Connecting the motor via terminal box ..... 16  
5.4 Connecting the brake via plug connector..... 19  
5.5 Connecting the brake via terminal box..... 23  
5.6 Optional equipment..... 24



**6 Startup..... 28**

6.1 Prerequisites for startup..... 28



**7 Malfunctions ..... 29**

7.1 Motor faults ..... 29  
7.2 Faults during operation with servo controller ..... 29  
7.3 Brake faults ..... 30



**8 Inspection and Maintenance ..... 31**

8.1 Inspection intervals ..... 31  
8.2 BR brake inspection work ..... 31



**9 Technical Data..... 33**

9.1 Plug connector ..... 33  
9.2 Connection with terminal box..... 33  
9.3 Work done, braking torques of BR brake..... 34  
9.4 Brake coil resistances ..... 34  
9.5 BR brake operating currents ..... 35



**10 Appendix..... 36**

10.1 Installation of power plug connectors SM5. / SM6. and SB5. / SB6. .... 36  
10.2 Installation of signal plug connectors ..... 37  
10.3 Wiring diagrams for CM synchronous servomotors ..... 38  
10.4 Wiring diagram for CM motors with plug connector ..... 39  
10.5 Wiring diagram for CM motors with signal plug connector..... 39  
10.6 Wiring diagram for CM motors with terminal box ..... 41  
10.7 Wiring diagram for VR forced cooling fan ..... 43

**11 Index..... 44**

11.1 Index of changes..... 44



## 1 Important Notes

### **Safety and warning instructions**

**Always observe the safety and warning instructions in this publication!**



#### **Electrical hazard**

Possible consequences: Severe or fatal injuries.



#### **Hazard**

Possible consequences: Severe or fatal injuries.



#### **Hazardous situation**

Possible consequences: Slight or minor injuries.



#### **Harmful situation**

Possible consequences: Damage to the drive and the environment.



Tips and useful information.



A requirement of fault-free operation and fulfillment of any rights to claim under guarantee is that you adhere to the information in the operating instructions. Consequently, read the operating instructions before you start operating the drive!

The operating instructions contain important information about servicing and should be kept in the vicinity of the unit.

### **Waste disposal**



#### **This product consists of:**

- Iron
- Aluminum
- Copper
- Plastic
- Electronics components

**Please dispose of the parts in accordance with the applicable regulations.**



## 2 Safety Notes

### **Preliminary remarks**

The following safety notes are principally concerned with the use of motors. If using **geared motors**, please also refer to the safety notes for gear units in the corresponding operating instructions.

**Please also take account of the supplementary safety notes in the individual sections of these operating instructions.**

### **General information**

During and after operation, motors and geared motors have live and moving parts and their surfaces may be hot.

**All work related to transportation, putting into storage, setting up/mounting, connection, startup, maintenance and repair should only be performed by trained personnel observing**

- the corresponding detailed operating instructions and wiring diagrams,
- the warning and safety signs on the motor/geared motor,
- the specific regulations and requirements for the system and
- national/regional regulations governing safety and the prevention of accidents.

**Severe injuries and damage to property may result from**

- incorrect use,
- incorrect installation or operation,
- removal of required protective covers or the housing when this is not permitted.

### **Intended usage**

These electric motors are intended for operation in industrial systems. They comply with the applicable standards and regulations and meet the requirements of the Low Voltage Directive 73/23/EEC.

The technical data and the information about permitted operating conditions can be found on the nameplate and in the documentation.

**It is essential to observe all specified information!**

### **Transportation / putting into storage**

**Inspect the delivery for any shipping damage as soon as you receive the delivery. Inform the shipping company immediately. It may be necessary to preclude startup.**

Tighten transportation lugs firmly. They are only designed for the weight of the motor/geared motor; do not attach any additional loads.

**The built-in lifting eyebolts meet DIN 580. The loads and regulations listed must always be observed. If the geared motor is equipped with two suspension eye lugs or lifting eyebolts, then both of the suspension eye lugs should be used for transportation. In this case, the tension force vector of the slings must not exceed a 45° angle in accordance with DIN 580.**

Use suitable, sufficiently rated handling equipment if necessary. Remove any transport fixtures prior to startup.

### **Installation / mounting**

Follow the instructions in the section 'Mechanical Installation'!

### **Inspection and maintenance**

Follow the instructions in the section 'Inspection and Maintenance'!



### 3 Motor Design



The following figure is a general representation of a motor. It serves as an allocation aid to the spare parts list. Possible deviations depend on motor size and design type!

#### 3.1 Basic design of CM synchronous servomotor

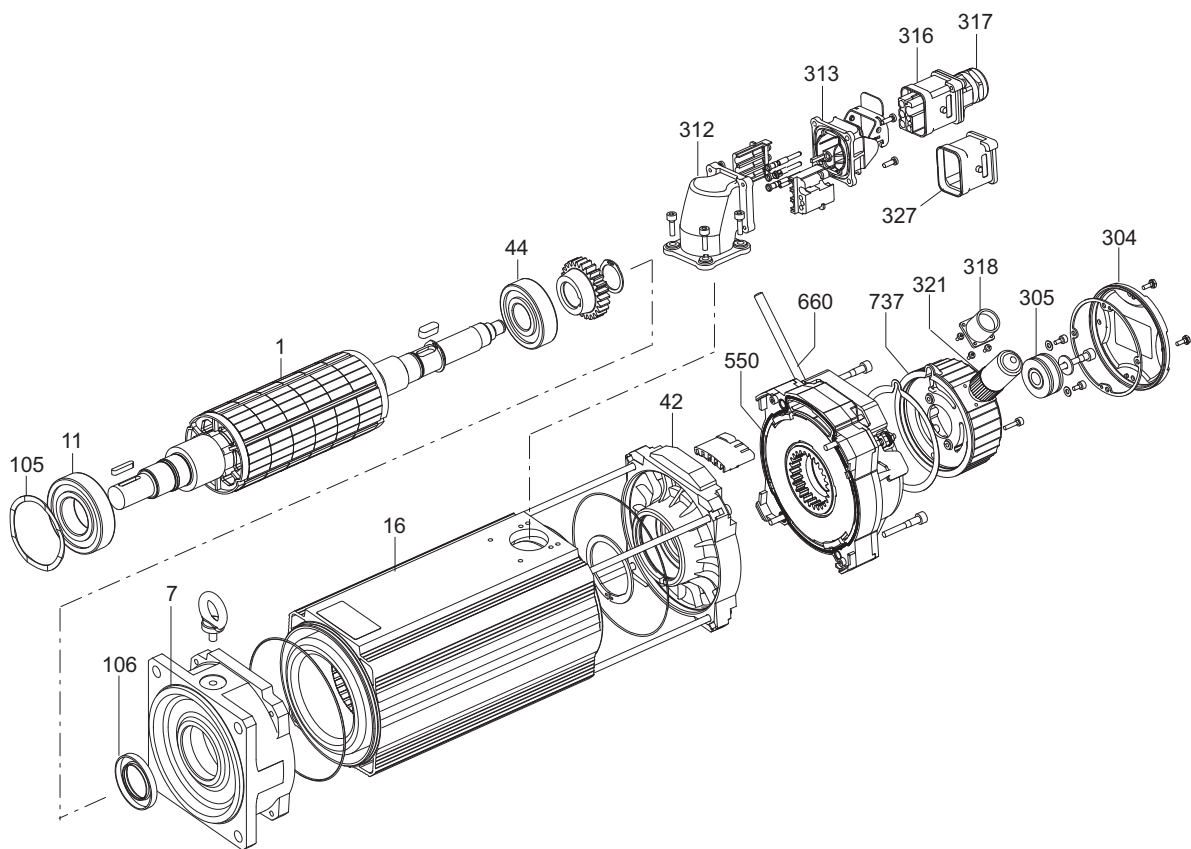

50955AXX

#### Legend

1	Rotor	312	Connector housing
7	Flanged end shield	313	Locking plate
11	Grooved ball bearing	316	Power plug, cpl.
16	Stator	317	Socket contact
42	Non-drive end bearing end shield	318	Flange-mounting socket, cpl.
44	Grooved ball bearing	321	Signal plug, cpl.
105	Equalizing ring	550	Brake, cpl.
106	Oil seal	660	Release lever
304	Housing cover	737	Encoder housing
305	Resolver		



### 3.2 Nameplate, unit designation

#### Nameplate

Example: CFM 71M /BR /TF /RH1M synchronous brake motor

<b>SEW-EURODRIVE</b>		Bruchsal/Germany		CE	
Typ	CFM 71M/BR/TF/RH1M	3~IEC 34		Permanentmagnet	
Nr.	01.123456789001.01.0001				
M O	6,5	Nm	I O	4,3	A f N 150 Hz
n N	3000	r/min	I max	17,2	A U max 400 V
IM	B5	kg	13	IP 65	isol.Kl. F
Getriebe	r/min	Nm	i	:1	
Bremse	V 230	Nm	14	Gleichrichter	BME
Schmierstoff	Made in Germany 199 081 0.10				

05694AXX

#### Unit designation

Example: CM synchronous brake motor

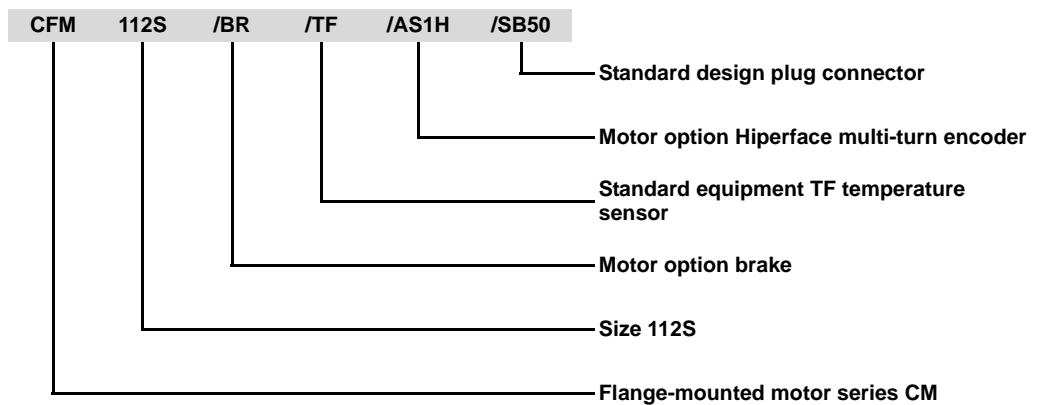

#### Example: Serial number

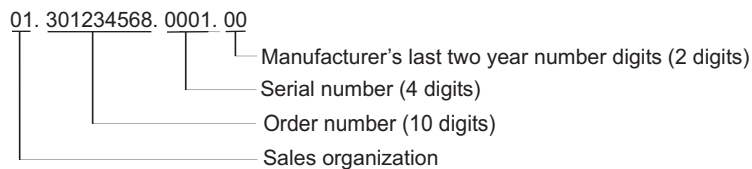

05156AEN



## 4 Mechanical Installation



It is essential to comply with the safety notes in section 2!

### 4.1 Required tools / resources

- Standard tool
- Mounting device
- Operation with conductor end sleeves: Crimping tool and conductor end sleeves (without insulation shroud, DIN 46228, Part 1, Material E-Cu)
- Crimping tool for plug connectors
- Removal tool

### 4.2 Before you begin

**The drive may only be installed if**

- the entries on the nameplate of the drive or the output voltage of the frequency inverter match the voltage supply system,
- the drive is undamaged (no damage caused by transportation or storage) and
- it is certain that the following requirements have been met:
  - ambient temperature between  $-25\text{ °C}$  and  $+40\text{ °C}$ ,<sup>1</sup>
  - No oil, acid, gas, vapors, radiation, etc.
  - Installation altitude max. 1000 m above sea level
  - Special versions: drive configured in accordance with the ambient conditions

### 4.3 Preliminary work

Motor shaft ends must be thoroughly cleaned of anti-corrosion agents, contamination or such like (use a commercially available solvent). Do not allow the solvent to penetrate the bearings or shaft seals – this could cause material damage!

**Extended storage of motors**

- Please note the reduced grease utilization period of the ball bearings after storage periods exceeding one year.
- Check whether the motor has absorbed moisture as a result of being stored for a long period. Measure the insulation resistance to do this (measuring voltage  $500\text{ V}_{\text{DC}}$ ).

1. If the AS1H / ES1H encoder is used, the coolant temperature must be limited to  $-20\text{ ... }+40\text{ °C}$ . Note that the temperature range of the gear unit may also be restricted (→ gear unit operating instructions)





The insulation resistance (→ following figure) varies greatly depending on the temperature! The motor must be dried if the insulation resistance is not adequate.

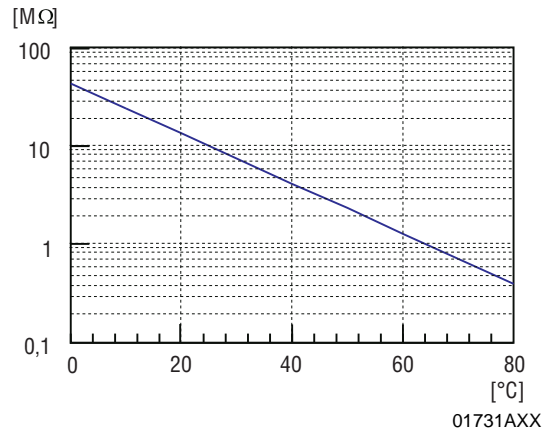

### **Drying the motor**

Warm up the motor with hot air. Open the motor compartment sufficiently so that moisture can escape from the inside.

Next check whether

- the connection space is dry and clean,
- the connections and fastening parts are free from corrosion,
- the joint seal is functioning,
- the cable screw fittings are tight, otherwise clean or replace them.



#### 4.4 Installing the motor



The motor or geared motor may only be mounted or installed in the specified mounting position on a level and torsionally rigid support structure which is not subjected to shocks.



Ensure exposed rotating parts are properly covered to ensure safety!



**The surface temperature of the motor may exceed 65 °C during operation. Provide protection to avoid unintentional contact.**

Carefully align the motor and the driven machine, to avoid placing any unnecessary strain on the output shafts (observe permitted overhung load and axial thrust forces!).

Do not butt or hammer the shaft extension.

**Use an appropriate cover to protect motors with VR forced cooling fan in vertical mounting positions from objects or fluids!**

If a forced cooling fan is used, ensure an unobstructed cooling air supply and that air heated by other devices cannot be drawn in by the fan.

Balance components with a half keyway for subsequent mounting on the shaft with a half key (motor shafts are balanced with a half key).

#### **Installation in damp areas or in the open**

If possible, arrange the motor and encoder connection so that the cable entries are pointing downwards.

Coat the threads of cable screw fittings and filler plugs with sealant and tighten them well – then coat them again.

Properly seal the cable entries.

Thoroughly clean the sealing surfaces of the connection space (motor/encoder connection) before reassembly. Fit new gaskets to replace embrittled ones!

Restore the anticorrosive coating if necessary.

Check the enclosure.

#### 4.5 Installation tolerances

Shaft end	Flanges
Diameter tolerance in accordance with DIN 748 <ul style="list-style-type: none"> <li>• ISO k6 at <math>\varnothing \leq 50</math> mm</li> <li>• ISO m6 at <math>\varnothing &gt; 50</math> mm</li> <li>• Center bore in accordance with DIN 332, shape DR..</li> </ul>	Centering shoulder tolerance in accordance with DIN 42948 <ul style="list-style-type: none"> <li>• ISO j6 at <math>\varnothing \leq 230</math> mm</li> <li>• ISO h6 at <math>\varnothing &gt; 230</math> mm</li> </ul>



## 5 Electrical Installation



It is essential to comply with the safety notes in section 2 during installation!

Switch contacts in utilization category AC-3 to EN 60947-4-1 must be used for switching the motor and the brake.

When motors are powered from inverters, you must adhere to the wiring instructions issued by the inverter manufacturer. It is essential to follow the servo controller operating instructions!

### 5.1 Wiring notes

**Protection  
against  
interference from  
brake control  
systems**

Do not route unshielded brake cables alongside switched-mode power cables, since there is a risk of disrupting brake controllers.

Switched-mode power cables include:

- Output cables from frequency and servo controllers, converters, soft start units and brake units
- Connecting harnesses to braking resistors, etc.

**Protection  
against  
interference from  
motor protection  
devices**

To provide protection against interference from motor protection devices (temperature sensor TF or KTY):

- Route separately shielded feeder cables together with switched-mode power lines in one cable
- Do not route unshielded feeder cables together with switched-mode power lines in one cable.



## 5.2 Connecting motor and encoder system via SM.. / SB.. plug connector

The CM motors are supplied with the SM.. / SB.. plug connector system. In the basic version, SEW-EURODRIVE delivers CM motors with flange-mounting socket on the motor side and without mating connector. The encoder system is connected using a separate 12-pole round plug connector. The encoder cable entry position is radial as standard.

### Line cross section

Make sure the type of line corresponds to the applicable regulations. The rated currents are specified on the motor nameplate. The applicable line cross sections are listed in the following table.

Type	Cable type	Line cross section
SM51 / SM61	Motor cables	4 x 1.5 mm <sup>2</sup>
SM52 / SM62		4 x 2.5 mm <sup>2</sup>
SM54 / SM64		4 x 4 mm <sup>2</sup>
SM56 / SM66		4 x 6 mm <sup>2</sup>
SM59 / SM69		4 x 10 mm <sup>2</sup>
SB51 / SB61	Brake motor cable	4 x 1.5 mm <sup>2</sup> + 3 x 1 mm <sup>2</sup>
SB52 / SB62		4 x 2.5 mm <sup>2</sup> + 3 x 1 mm <sup>2</sup>
SB54 / SB64		4 x 4 mm <sup>2</sup> + 3 x 1 mm <sup>2</sup>
SB56 / SB66		4 x 6 mm <sup>2</sup> + 3 x 1.5 mm <sup>2</sup>
SB59 / SB69		4 x 10 mm <sup>2</sup> + 3 x 1.5 mm <sup>2</sup>

### Pre-fabricated cables

Pre-fabricated cables are available from SEW-EURODRIVE to connect the SM../SB.. plug connector system. The core designation and contact assignment are listed in the following table.

The plug connectors are depicted with the connector assignment on the cable at the connection side (back).

If you are fabricating the cables yourself:

- The section 'Appendix' describes the installation of the SM5./SM6. power plug connectors and signal plug connectors.
- The socket contacts for the motor connection are implemented as crimping contacts. Use only suitable tools for crimping.
- Strip the leads according to section 'Appendix', Installation of SM5. / SM6. power plug connectors or signal plug connectors. Apply shrink tubing to connectors.
- Use only suitable removal tools to remove incorrectly installed socket contacts.



Contact assignment of motor cables SM5./SM6. power plug connector / SK5 coupling

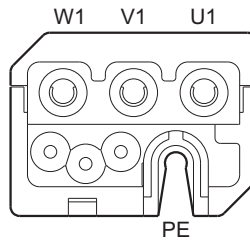

50952AXX

Contact	Core identification	Connection	Type of contact
U1	Black with white lettering U, V, W	U	Cut-off free length approx. 250 mm
V1		V	
W1		W	
PE	Green/yellow	Protective earth	

Contact assignment of brake motor cables SB5./SB6. power plug connector / SK5 coupling

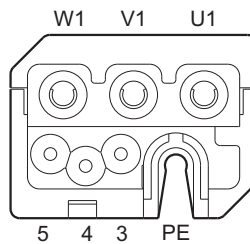

50953AXX

Contact	Core identification	Connection	Type of contact
U1	Black with white lettering U, V, W	U	Cut-off free length approx. 250 mm
V1		V	
W1		W	
PE	Green/yellow	Protective earth	
3	Black with white lettering 1, 2, 3	1	with Phoenix plug connector GMVSTBW 2.5/3ST
4		2	
5		3	



Contact assignment of signal plug connector of encoder cable for Hiperface encoder AS1H / ES1H

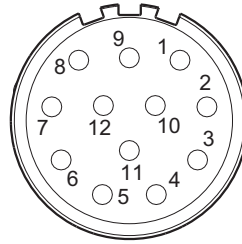

50954AXX

Contact no.	Core identification	Assigned
1	-	-
2		
3	(RD) Red	Cosine +
4	(BU) Blue	Refcos:
5	(YE) Yellow	Sine +
6	(GN) Green	Refsin:
7	(VT) Violet	Data -
8	(BK) Black	Data +
9	(BN) Brown	TF (KTY+)
10	(WH) White	TF (KTY-)
11 <sup>1)</sup>	(GY/PK) Gray/pink + (PK) pink	Voltage reference (GND)
12 <sup>1)</sup>	(RD/BU) Red/blue + (GY) gray	Supply voltage Vs

1) Double assignment to increase cross section



Contact assignment of signal plug connector of encoder cable for RH1M resolver

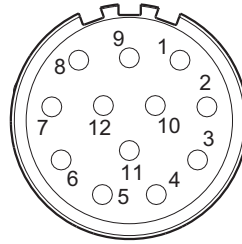

50954AXX

Contact no.	Core identification	Assigned
1	(PK) Pink	R1 (reference +)
2	(GY) Gray	R2 (reference -)
3	(RD) Red	S1 (cosine +)
4	(BU) Blue	S3 (cosine -)
5	(YE) Yellow	S2 (sine +)
6	(GN) Green	S4 (sine -)
7	-	-
8	-	-
9 <sup>1)</sup>	(BN) Brown + (VT) violet	TF (KTY+)
10 <sup>1)</sup>	(WH) White + (BK) black	TF (KTY-)
11	-	-
12	-	-

1) Double assignment to increase cross section



### 5.3 Connecting the motor via terminal box



In case of operation with electronic control units, it is essential to adhere to the corresponding operating instructions/wiring diagrams!



The core colors listed in the following tables correspond to the color code for SEW-EURODRIVE cables.

#### Connecting the motor via terminal box

- According to the enclosed wiring diagram (→ 'Connection wiring diagrams' in the section 'Appendix')
- Check the cross sections of cables
- Tighten connections and protective earth conductors
- In terminal boxes: Check winding connections and tighten if necessary

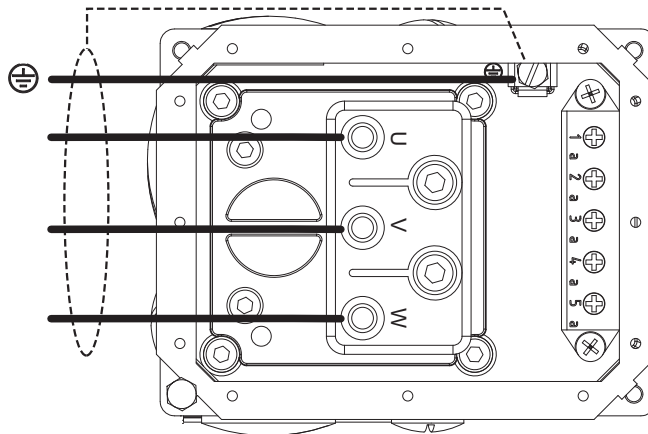

52150AXX

Contact	Core identification	Connection
U1	Black with white lettering U, V, W	U
V1		V
W1		W
PE	Green/yellow	Protective earth





**Connecting the resolver / thermal motor protection**

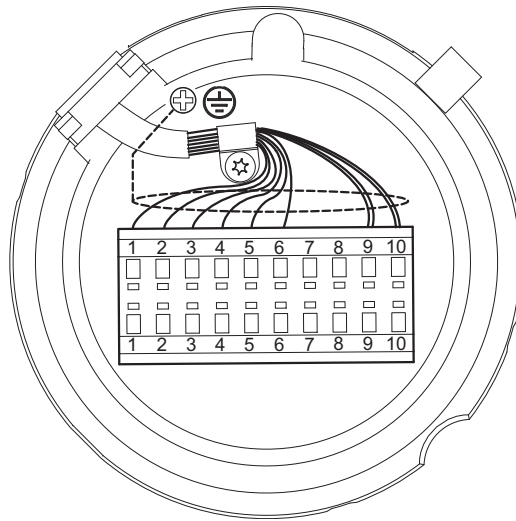

51212AXX

Signal lines from RH1M resolver and TF (KTY) thermal motor protection on the terminal strip:

Contact	RH1M / TF core identification	Connection
1	(PK) Pink	R1 (reference +)
2	(GY) Gray	R2 (reference -)
3	(RD) Red	S1 (cosine +)
4	(BU) Blue	S3 (cosine -)
5	(YE) Yellow	S2 (sine +)
6	(GN) Green	S4 (sine -)
7	-	-
8	-	-
9 <sup>1)</sup>	(BN) Brown + (VT) violet	TF (KTY+)
10 <sup>1)</sup>	(WH) White + (BK) black	TF (KTY-)

1) Double assignment to increase cross section



**Connecting the  
AS1H / ES1H  
Hiperface  
encoder**

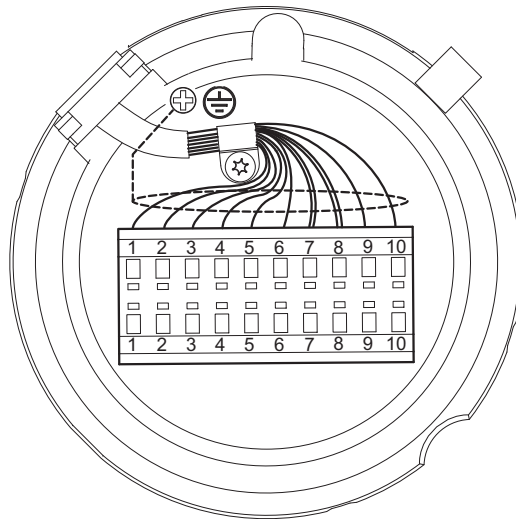

51213AXX

Signal lines of the AS1H / ES1H Hiperface encoder on the terminal strip:

Contact	AS1H / ES1H core identification	Connection
1	(RD) Red	Cosine +
2	(BU) Blue	Refcos:
3	(YE) Yellow	Sine +
4	(GN) Green	Refsin:
5	(VT) Violet	Data -
6	(BK) Black	Data +
7 <sup>1)</sup>	(GY/PK) Gray/pink + (PK) pink	Voltage reference (GND)
8 <sup>1)</sup>	(RD/BU) Red/blue + (GY) gray	Supply voltage Vs
9	(BN) Brown	TF (KTY+)
10	(WH) White	TF (KTY-)

1) Double assignment to increase cross section



### 5.4 Connecting the brake via plug connector

The brake is released electrically. The brake is applied mechanically when the voltage is switched off.



**Comply with the applicable regulations issued by the relevant employer's liability insurance association regarding phase failure protection and the associated circuit/circuit modification!**

- **Note:** In view of the DC voltage to be switched and the high level of current load, it is essential to use either special brake contactors or AC contactors with contacts in utilization category AC-3 to EN 60947-4-1.
- You may have to install a hand lever for designs with manual brake release.

### Connecting the BM.. brake rectifier / BSG brake control unit

The BM.. brake rectifiers or the BSG brake control unit are installed in the switch cabinet. The brake is connected with a 4-core cable.



- **Check power cross sections - braking currents (→ section 'Technical Data')**
- Connect the brake control system according to the corresponding wiring diagram (→ the following graphics)

*BME brake rectifier* AC circuit disconnect/ standard application of the brake

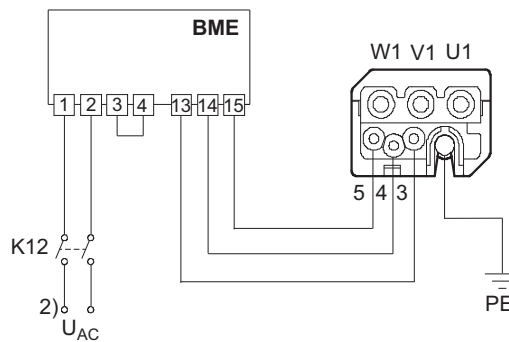

51231AXX

DC and AC circuit disconnect / quick application of the brake

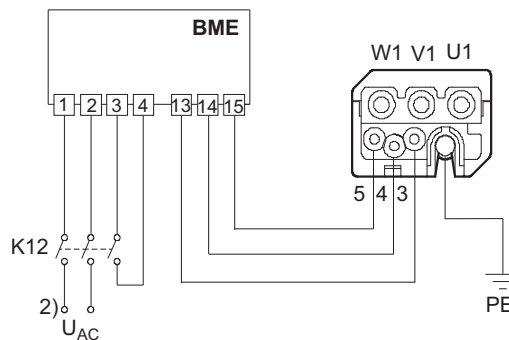

51232AXX



*BMP brake rectifier* AC circuit disconnect / quick application of the brake / integrated voltage relay

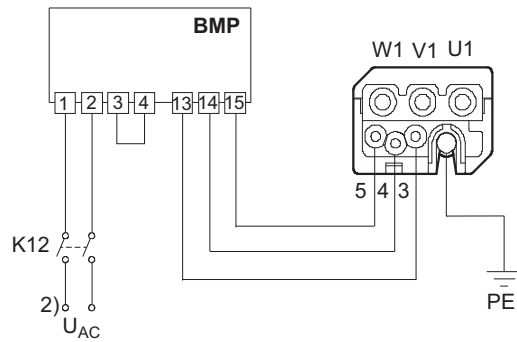

51234AXX

DC circuit disconnect / quick application of the brake / integrated voltage relay

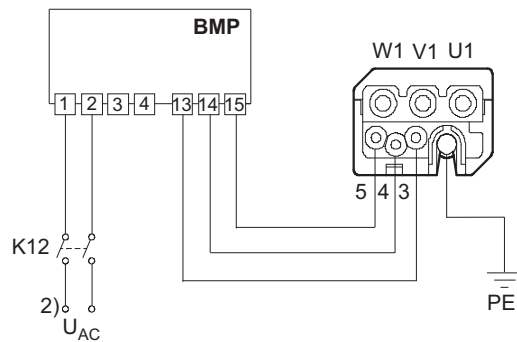

51233AXX

*BMH brake rectifier* AC circuit disconnect / standard application of the brake

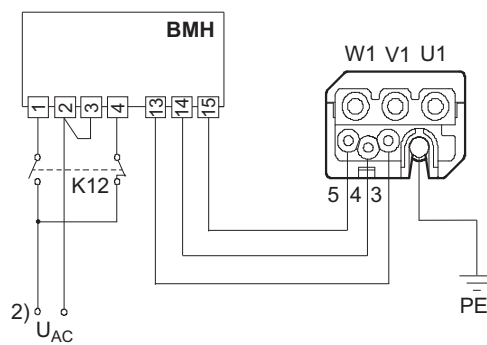

51235AXX



DC and AC circuit disconnect / quick application of the brake

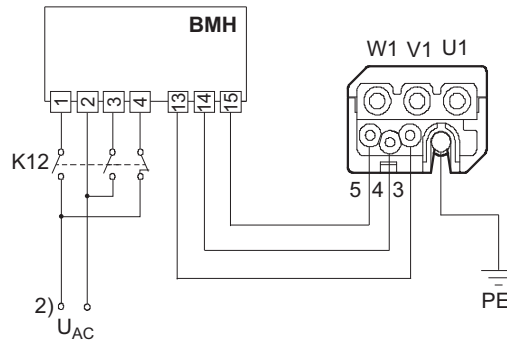

51236AXX

*BMK brake rectifier* DC and AC circuit disconnect / quick application of the brake / integrated voltage relay / integrated 24 V<sub>DC</sub> control input

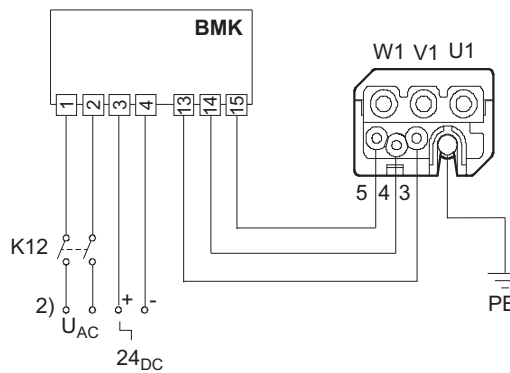

51237AXX

Legend

- 1 Brake coil
- 2 Apply voltage as indicated on the nameplate to release the brake, **switch contacts according to utilization category AC3 to EN 609947-4-1**  
**BMH:** To release and heat the brake at zero speed, apply the voltage as indicated on the nameplate. K12 not activated: Heating operation. Contact rating of terminals 1 and 4 at BMH: AC11, terminal 3: AC3 in accordance with EN 60947-4-1
- 3 Connection cable for brake motor



*BSG brake control unit* For 24 V<sub>DC</sub> voltage supply

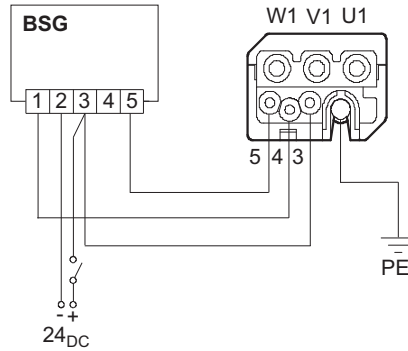

51238AXX

*Legend*

- 1 Brake coil
- 2 Connection cable for brake motor



**5.5 Connecting the brake via terminal box**

The brake is released electrically. The brake is applied mechanically when the voltage is switched off.



**Comply with the applicable regulations issued by the relevant employer’s liability insurance association regarding phase failure protection and the associated circuit/circuit modification!**

- **Note:** In view of the DC voltage to be switched and the high level of current load, it is essential to use either special brake contactors or AC contactors with contacts in utilization category AC-3 to EN 60947-4-1.
- You may have to install a hand lever for designs with manual brake release.

**Connecting the brake via terminal box**

- According to the enclosed wiring diagram (→ 'Connection wiring diagrams' in the section 'Appendix')
- Check the cross sections of cables
- Fully tighten the connections

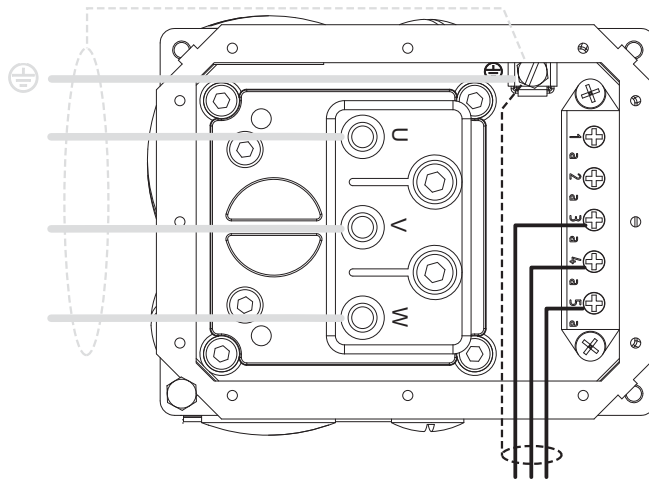

52151AXX

Contact of auxiliary terminal strip	Core identification	Connection BME, BMH, BMK, BMP brake rectifiers	Connection BSG brake control unit
3a	Black with white lettering 1, 2, 3	14	1
4a		13	3
5a		15	5



### 5.6 Optional equipment



Connect the supplied optional equipment according to the enclosed wiring diagrams. The wiring diagrams can also be found in the section 'Appendix.'

#### Temperature sensor TF



**Do not apply any voltage!**

The positive temperature coefficient (PTC) thermistors comply with DIN 44082.

Resistance measurement (measuring instrument with  $V \leq 2.5 \text{ V}$  or  $I < 1 \text{ mA}$ ):

- Standard measured values: 20...500  $\Omega$ , resistance when hot > 4000  $\Omega$

#### Temperature sensor KTY

- It is absolutely necessary to observe the correct connection of the KTY to ensure a correct evaluation of the temperature sensor.
- Avoid currents > 4 mA in the circuit of the KTY since high self-heating of the temperature sensor can damage its insulation and the motor winding.

The characteristic curve in the following figure shows the resistance curve with a measuring current of 2 mA.

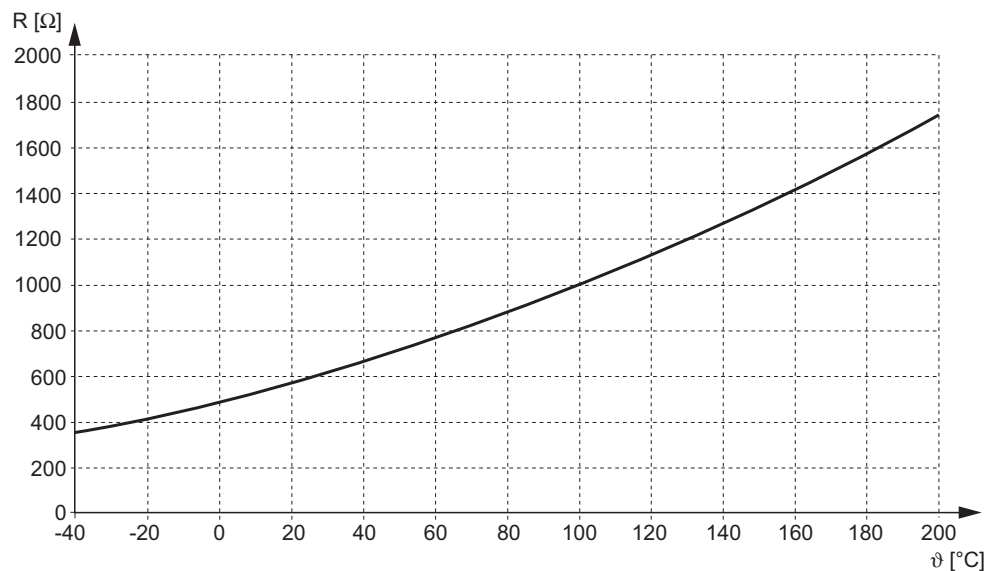

50927AXX





**VR forced cooling fan**

Upon request, the synchronous servomotors can be fitted with a VR forced cooling fan.

*Mechanical installation*

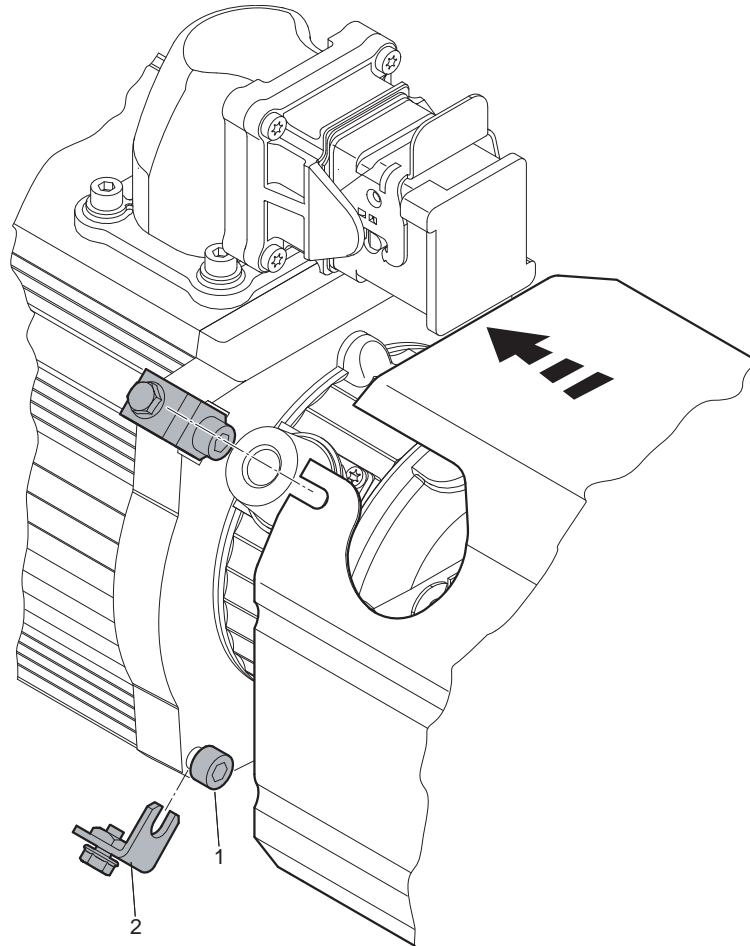

51279AXX

The VR forced cooling fan is mounted on the non-drive end bearing shield using 4 holding fixtures:



**Please always completely mount the holding fixture (2) on one machine screw (1) at a time, else the encoder system settings might change!**

- Unscrew the machine screw (1) by 2 to 3 turns.
- Position the holding fixture (2) in the opening of the non-drive end bearing shield.
- Tighten the machine screw (1). Note the tightening torque:

Motor size	Tightening torque [Nm]
CM71	7 (M5)
CM90	13 (M6)
CM112	28 (M8)

- Repeat this mounting procedure for the other 3 holding fixtures.
- Attach the forced cooling fan to the mounted holding fixtures.



### Electrical connection

The VR forced cooling fan is available for a DC voltage of 24 V and for an AC voltage of 100 to 240 V (→ section 'Appendix', Wiring diagram for VR forced cooling fan).

- 24 V<sub>DC</sub> ± 20 %
- Plug connection
- Max. connection cross section 3x1 mm<sup>2</sup>
- Cable screw fitting Pg7 with 7 mm inside diameter

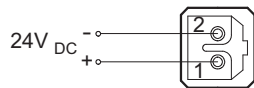

50990AXX

Plug contact	Connection
1	24 V +
2	0 V

### UWU51A switched-mode power supply

The AC version consists of a VR forced cooling fan and the UWU51A switched-mode power supply (→ following figure).

- Input: 100 ... 240 V<sub>AC</sub> – 6 % / + 10 %, 50/60 Hz
- Output: 24 V<sub>DC</sub> – 1 % / + 2 %, 1.25 A
- Connection: Screw terminals 0.2...2.5 mm<sup>2</sup>, separable
- Enclosure: IP20; mounted on mounting rail EN 50022 in the switch cabinet

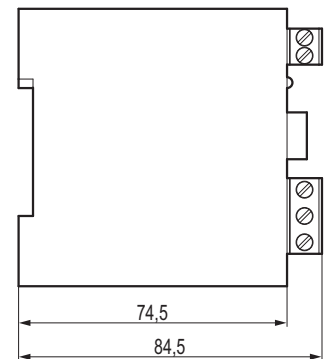
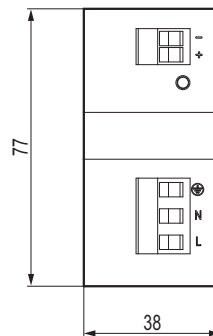
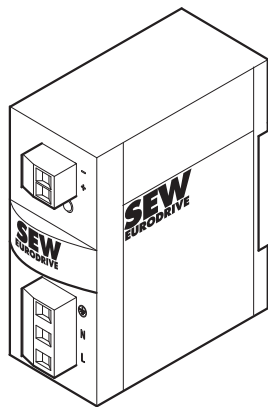

50919AXX



**Hiperface encoder**

The following notes must be observed when connecting the AS1H / ES1H Hiperface encoder:

- Only use a shielded cable with twisted pair conductors.
- Connect the shield to the PE potential on both ends over a large surface area.
- Route signal cables separately from power cables or brake cables (min. distance 200 mm)



**SEW-EURODRIVE recommends to not remove the signal plug connector of the AS1H / ES1H Hiperface encoder while the unit is energized.**

Connection to **MOVIDRIVE<sup>®</sup> compact MCH4\_A**

For operation with **MOVIDRIVE<sup>®</sup> compact MCH4\_A**, the encoder is connected via plug connector or via terminal box depending on motor type and motor design (→ following figures; the colors correspond to the color code for SEW-EURODRIVE cables)

For the **CM71...112 motor design with plug connector**, connect the Hiperface encoder to **MOVIDRIVE<sup>®</sup> compact MCH4\_A** as follows:

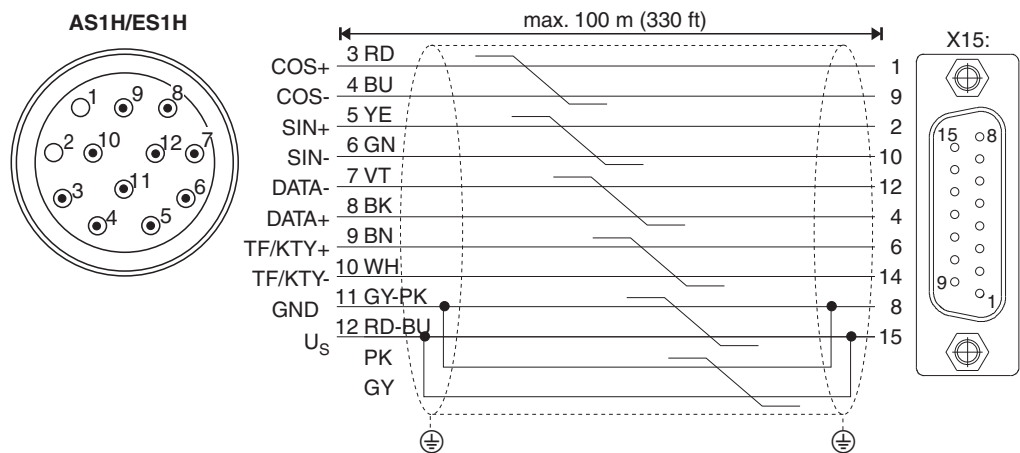

05740AXX

For the **CM71...112 motor design with terminal box**, connect the Hiperface encoder to **MOVIDRIVE<sup>®</sup> compact MCH4\_A** as follows:

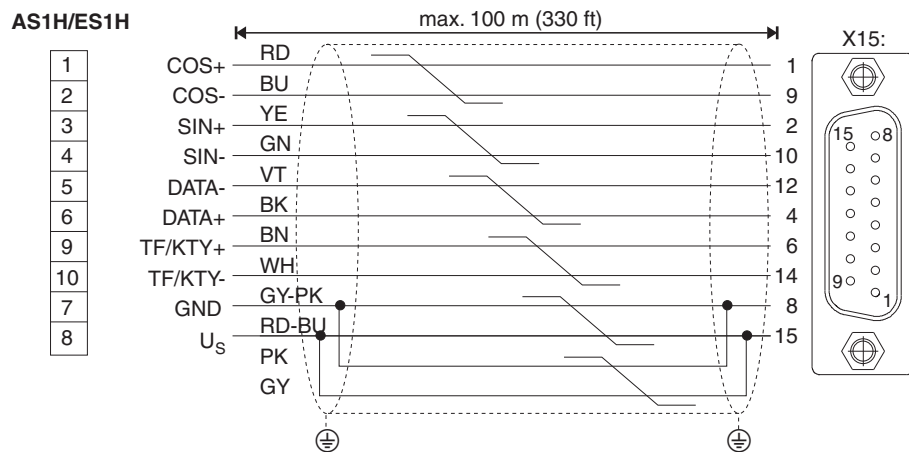

05919AXX



## 6 Startup

### 6.1 Prerequisites for startup



**It is essential to comply with the safety notes in section 2!**

***Before startup, make sure that***

- the drive is undamaged and not blocked,
- the measures stipulated in section 'General Preparations' are performed after extended storage period,
- all connections have been made properly,
- the direction of rotation of the motor/geared motor is correct,
- all protective covers have been fitted correctly,
- all motor protection devices are activated,
- in the case of hoist drives, the self-reengaging manual brake release is used,
- there are no other sources of danger present.

***During startup, make sure that***

- the motor is running correctly (no overload, no speed fluctuation, no loud noises, etc.),
- the correct braking torque is set according to the respective application (→ section 'Technical Data'),
- in case of problems (→ section 'Malfunctions')



**On brake motors with self-reengaging manual brake releases, the lever must be removed after startup!**



## 7 Malfunctions

### 7.1 Motor faults

Fault	Possible cause	Remedy
Motor does not start up	Interruption in connecting harness	Check connections, correct if necessary
	Fuse blown	Fit new fuse
	Motor protection has tripped	Check motor protection for correct setting, correct fault if necessary.
Incorrect direction of rotation	Motor connected incorrectly	Check inverter, check setpoints
Motor hums and has high current consumption	Drive is blocked	Check drive
	Brake does not release	→ section 'Brake faults'
	Fault on encoder cable	Check encoder cable
Motor heats up excessively (measure temperature)	Overload	Perform power measurement, use larger motor or reduce load if necessary
	Inadequate cooling	Correct cooling air supply or clear cooling air passages, retrofit forced cooling fan if necessary
	Ambient temperature too high	Adhere to permitted temperature range
	Forced cooling fan does not run	Check connection, correct if necessary
	Rated operation type (S1 to S10, DIN 57530) exceeded, e.g. through excessive starting frequency	Adjust rated operation type of motor to required operating conditions; if necessary call in a specialist to determine the correct drive
Running noise on motor	Bearing damage	Consult with SEW-EURODRIVE customer service

### 7.2 Faults during operation with servo controller



The symptoms described in the section 'Motor faults' may also occur when the motor is operated with a servo controller. Please refer to the servo controller operating instructions for the significance of the problems which occur and to find information about rectifying the problems.

**Please have the following information ready when contacting customer service:**

- Nameplate data (complete)
- Nature and extent of the fault
- Time and peripheral circumstances of the fault
- Presumed cause



### 7.3 Brake faults

Fault	Possible cause	Remedy
Brake does not release	Incorrect voltage on brake control unit	Apply correct voltage
	Brake control unit failed	Replace brake control system, check internal resistance and insulation of brake coil, check switchgear
	Max. permitted working air gap exceeded because brake lining worn down	Consult with SEW-EURODRIVE customer service
	Voltage drop on connecting harness > 10 %	Correct connection voltage; check cable cross section
	Brake coil has interturn fault or short circuit to exposed conductive part	Consult with SEW-EURODRIVE customer service
Motor does not brake	Brake lining worn down	Consult with SEW-EURODRIVE customer service
	Incorrect braking torque	Consult with SEW-EURODRIVE customer service
	Manual brake release device not set correctly	Set the setting nuts correctly
Brake is applied with time lag	Brake is switched on AC voltage side	Switch on DC and AC voltage sides; observe wiring diagram
Noise in the brake area	Pulsating torques due to incorrectly set frequency inverter	Check/correct setting of frequency inverter according to operating instructions



## 8 Inspection and Maintenance



- Use only genuine spare parts in accordance with the valid parts list!
- Motors can become very hot during operation – danger of burns!
- Disconnect the motor and brake from the power supply before starting work, safeguarding them against unintentional power-up!
- Maintenance work on the BR brake may only be performed by SEW-EURODRIVE since the encoder must be readjusted after every disassembly.

### 8.1 Inspection intervals

The periods of wear are affected by many factors and may be short. The machine designer must calculate the required inspection intervals individually in accordance with the project planning documents (e.g. Drive Engineering - Practical Implementation – Drive Project Planning, Geared Servomotors catalog).

### 8.2 BR brake inspection work



#### **Measuring the working air gap**

Important: Load held by brake may be released during brake maintenance and adjustment procedures. The load must be supported by alternate means while working on brake!

The working air gap  $\Delta H$  ( $\rightarrow$  following figure) can be measured using the stroke of the pressure plate via the studs during the release (permitted range: 0.15...0.8 mm).

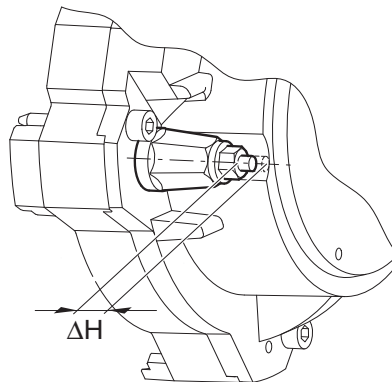

50940AXX



### Retrofitting the manual brake release

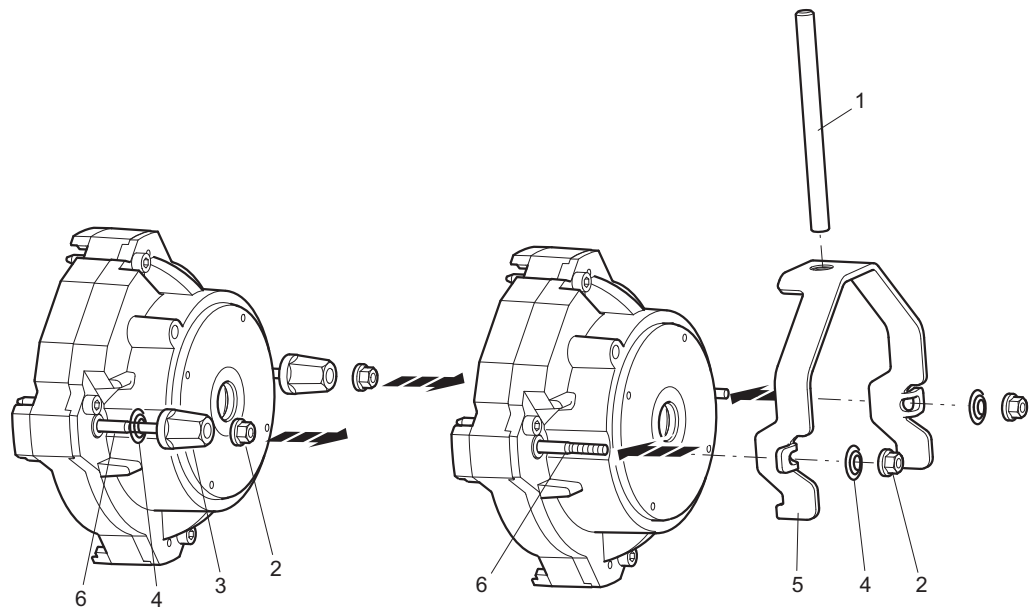

50941AXX

#### Legend

1	Hand lever	4	Conical coil spring
2	Hex nut	5	Releasing lever
3	Sleeve	6	Stud

- Unscrew both hex nuts (2), remove sleeves (3) and conical coil springs (4).
- Attach releasing lever (5) to studs (6). Attach existing conical coil springs (4) to studs (6). Screw hex nuts (2) onto studs (6). Screw hand lever (1) into releasing lever (5).
- Adjust floating clearance  $s$  of 2 mm on both sides between the lug of the releasing lever (5) and the hex nut (2) (→ following figure).

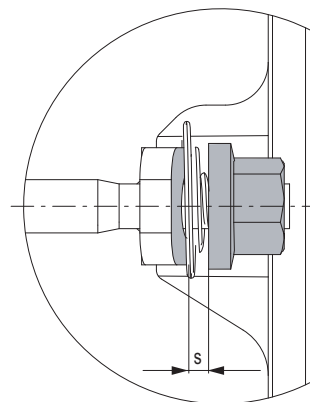

50950AXX



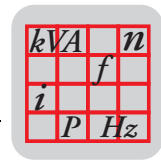

## 9 Technical Data

### 9.1 Plug connector

Plug connector	Power plug connector			Signal plug connector		
	Socket contact	Cable entry	Max. cable diameter [mm]	Socket contact	Cable entry	Max cable diameter [mm]
SM51/SM61	4 x 1.5 mm <sup>2</sup>	M28	14	10 x 0.06...1 mm <sup>2</sup>	Variable	10.5
SB51/SB61	4 x 1.5 mm <sup>2</sup> + 3 x 0.5...1.5 mm <sup>2</sup>					
SM52/SM62	4 x 2.5 mm <sup>2</sup>					
SB52/SB62	4 x 2.5 mm <sup>2</sup> + 3 x 0.5...1.5 mm <sup>2</sup>					
SM54/SM64	4 x 4 mm <sup>2</sup>					
SB54/SB64	4 x 4 mm <sup>2</sup> + 3 x 0.5...1.5 mm <sup>2</sup>					
SM56/SM66	4 x 6 mm <sup>2</sup>	M34	23	10 x 0.06...1 mm <sup>2</sup>	Variable	10.5
SB56/SB66	4 x 6 mm <sup>2</sup> + 3 x 0.5...1.5 mm <sup>2</sup>					
SM59/SM69	4 x 10 mm <sup>2</sup>					
SB59/SB69	4 x 10 mm <sup>2</sup> + 3 x 0.5...1.5 mm <sup>2</sup>					

### 9.2 Connection with terminal box

Motor type	Power connection			Encoder connection	
	Connection	Maximum line cross section	Cable entry	Connection	Cable entry
CFM71..	3 x M5	4 x 4 mm <sup>2</sup>	M20 x 1.5	Terminal with cage clamp in encoder housing	M16 x 1.5
CFM90../112S	3 x M6	4 x 10 mm <sup>2</sup>	M32 x 1.5		
CFM112..M/L			M40 x 1.5		
CFM112H			M50 x 1.5		

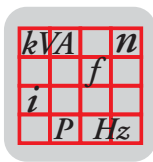

### 9.3 Work done, braking torques of BR brake

Brake	For motor size	Work done until maintenance [10 <sup>6</sup> J]	Braking torque [Nm]
BR1	CM71	60	5 7 10 14 20
BR2	CM90	90	14 20 28 40
BR8	CM112	180	28 40 55 80 110

### 9.4 Brake coil resistances

Brake	V <sub>rated</sub>									
	24 V <sub>DC</sub>		110 V <sub>AC</sub>		230 V <sub>AC</sub>		400 V <sub>AC</sub>		460 V <sub>AC</sub>	
	R <sub>B</sub> [Ω]	R <sub>T</sub> [Ω]	R <sub>B</sub> [Ω]	R <sub>T</sub> [Ω]	R <sub>B</sub> [Ω]	R <sub>T</sub> [Ω]	R <sub>B</sub> [Ω]	R <sub>T</sub> [Ω]	R <sub>B</sub> [Ω]	R <sub>T</sub> [Ω]
BR1	3.74	11.2	11.8	35.4	59.2	178	187	561	235.7	707
BR2	3.23	9.55	10.2	30.2	51.3	151	162	479	194	573
BR8	1.33	6.95	4.2	21.9	21	110	66.4	348	83.6	438

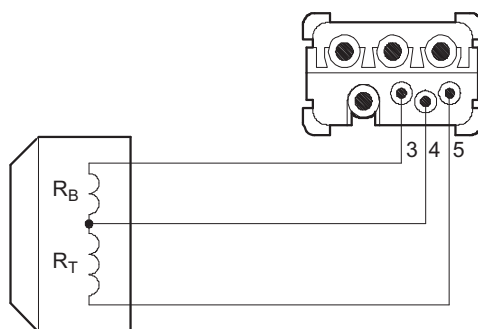

51242AXX

#### Legend

- R<sub>B</sub> Accelerator coil resistance at 20 °C
- R<sub>T</sub> Coil section resistance at 20 °C
- V<sub>rated</sub> Rated voltage (rated voltage range)

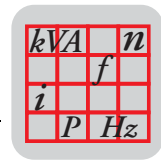

**9.5 BR brake operating currents**

The current values  $I_H$  (holding current) specified in the tables are r.m.s. values. Use only r.m.s. instruments for your measurement. The inrush current (accelerator current)  $I_B$  only flows for a short time (max. 150 ms) when the brake is released or during voltage dips below 70 % of the rated voltage. There is no increased inrush current if the BG brake rectifier is used or if there is a direct DC voltage supply – both are only possible with brakes up to motor size BMG4.

	BR1	BR2	BR8
Motor	CM71	CM90	CM112
Max. braking torque [Nm]	20	40	110
Braking power [W]	45	55	75
Inrush current ratio $I_B/I_H$	4.0	4.0	6.3

Rated voltage $V_{rated}$		BR1	BR2	BR8
$V_{AC}$	$V_{DC}$	$I_H$ [A <sub>AC</sub> ]	$I_H$ [A <sub>AC</sub> ]	$I_H$ [A <sub>AC</sub> ]
	24	1.5	1.7	2.6
110		0.71	0.9	1.20
230		0.31	0.39	0.53
400		0.18	0.22	0.29
460		0.16	0.21	0.26

*Legend*

- $I_B$  Accelerator current – short-term inrush current
- $I_H$  Holding current r.m.s. value in the connecting harness to the SEW brake rectifier
- $V_{rated}$  Rated voltage (rated voltage range)



## 10 Appendix

### 10.1 Installation of power plug connectors SM5. / SM6. and SB5. / SB6.

Ø	a	b
8 - 17 mm	43 mm	54 mm
7 - 23 mm	52 mm	63 mm

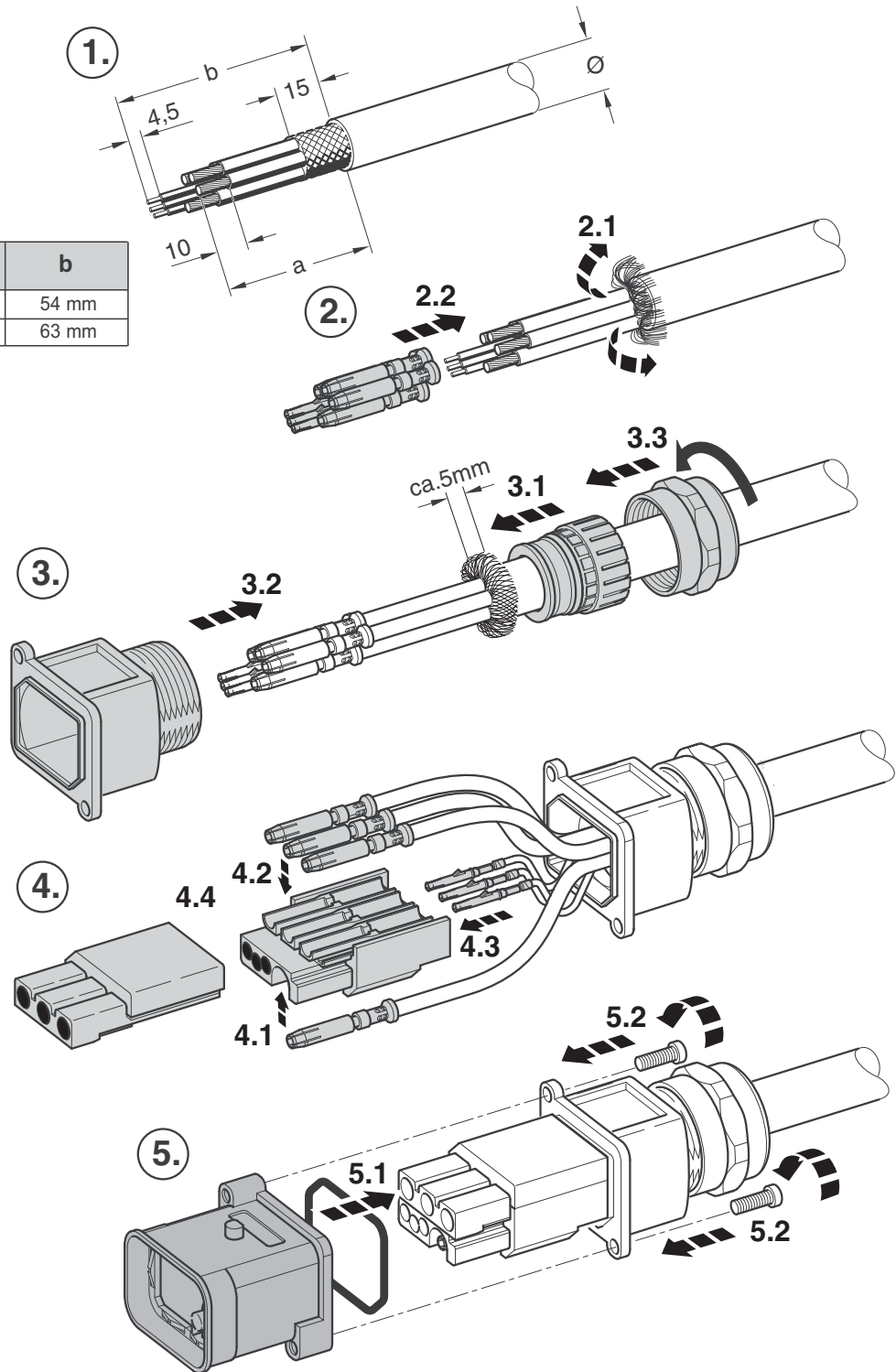

51211AXX

### 10.2 Installation of signal plug connectors

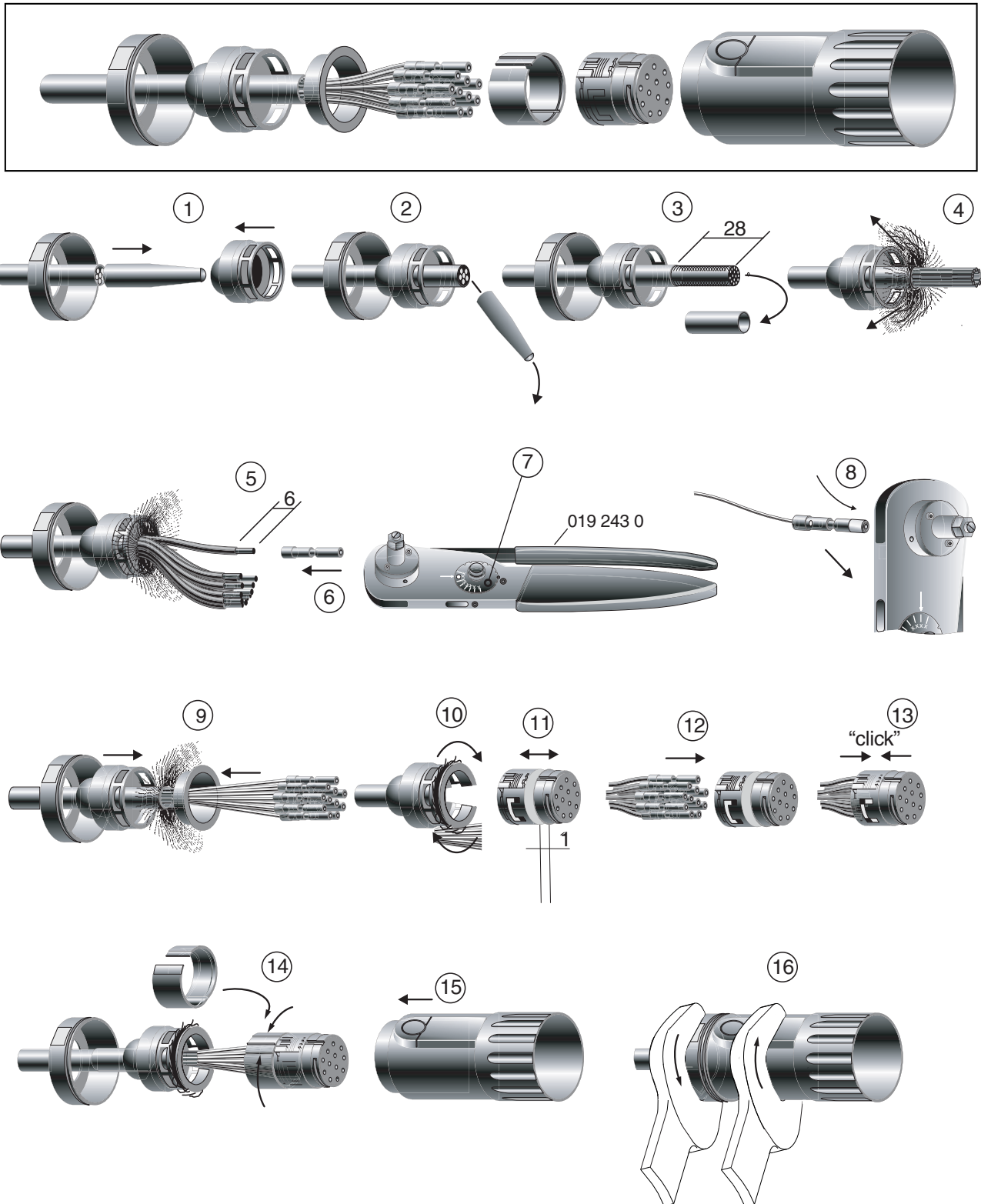

51210AXX



### 10.3 Wiring diagrams for CM synchronous servomotors





The following applies to all wiring diagrams:

- View to the wiring side
- Color code according to SEW-EURODRIVE cables:

Color code	Color
BK	Black
BN	Brown
BU	Blue
GN	Green
GY	Gray
OG	Orange
PK	Pink
RD	Red
VT	Violet
WH	White
YE	Yellow
GYPK	Gray/pink
RDBU	Red/blue
BKWH	Black/White
RDWH	Red/white

#### Symbols used

	Plug connector upper part (connected by the customer)
	Plug connector lower part (connected in the factory)

### 10.4 Wiring diagram for CM motors with plug connector

Wiring diagram with / without brake

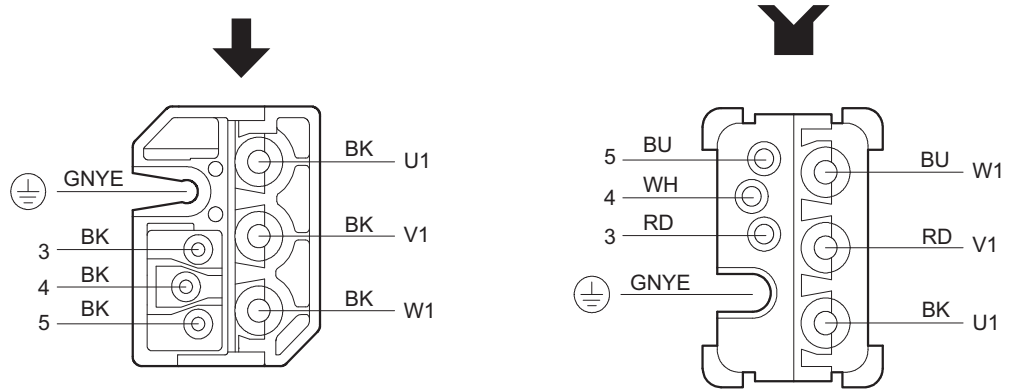

51214AXX

### 10.5 Wiring diagram for CM motors with signal plug connector

Wiring diagram for RH1M resolver

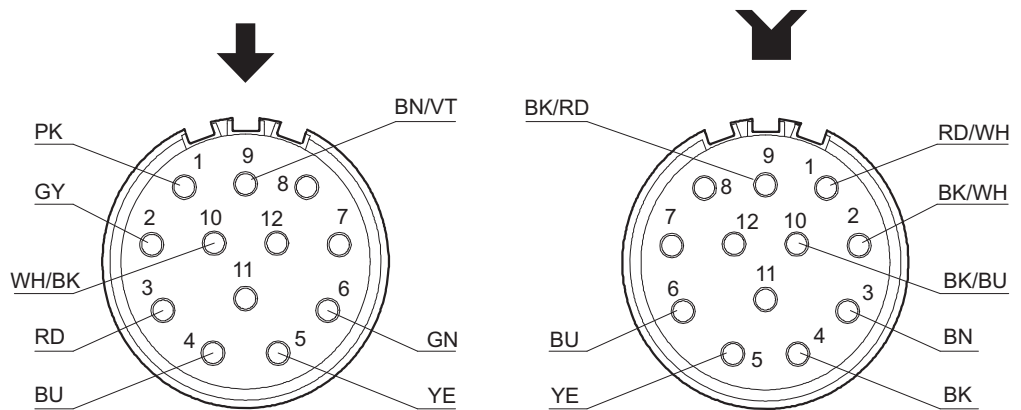

51216AXX

Contact assignment of plug connector lower part

Contact	Color code	Connection
1	RDWH	R1 (reference +)
2	BKWH	R2 (reference -)
3	RD	S1 (cosine +)
4	BK	S3 (cosine -)
5	YE	S2 (sine +)
6	BU	S4 (sine -)
7	-	-
8	-	-
9	BK / RD	TF / KTY +
10	BK / BU	TF / KTY -
11	-	-
12	-	-

## Wiring diagram for ES1H, AS1H encoders

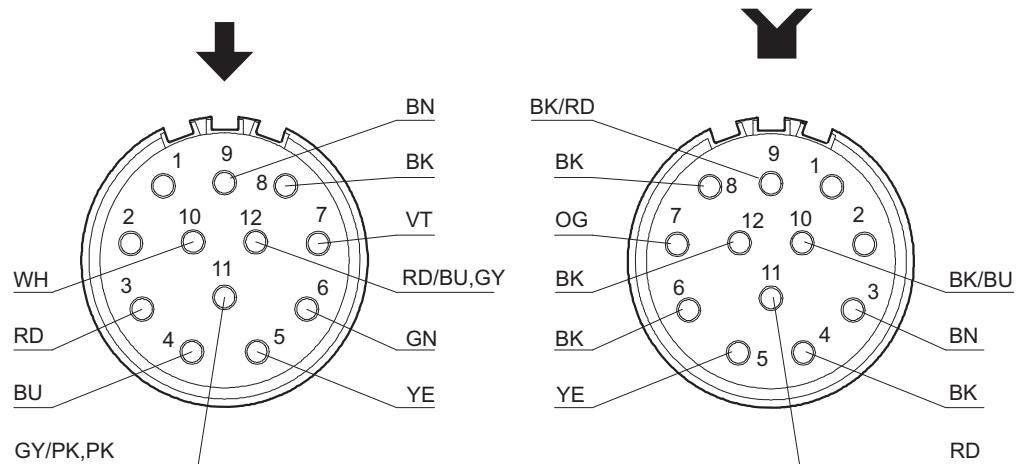

51217AXX

Contact assignment of plug connector lower part

Contact	Color code	Connection
1	-	-
2	-	-
3	BN	Cosine +
4	BK	Refcos -
5	YE	Sine +
6	BK	Refsine -
7	OG	D -
8	BK	D +
9	BK / RD	TF / KTY +
10	BK / BU	TF / KTY -
11	RD	Voltage reference (GND)
12	BK	Supply voltage Vs



### 10.6 Wiring diagram for CM motors with terminal box

Wiring diagram with / without brake

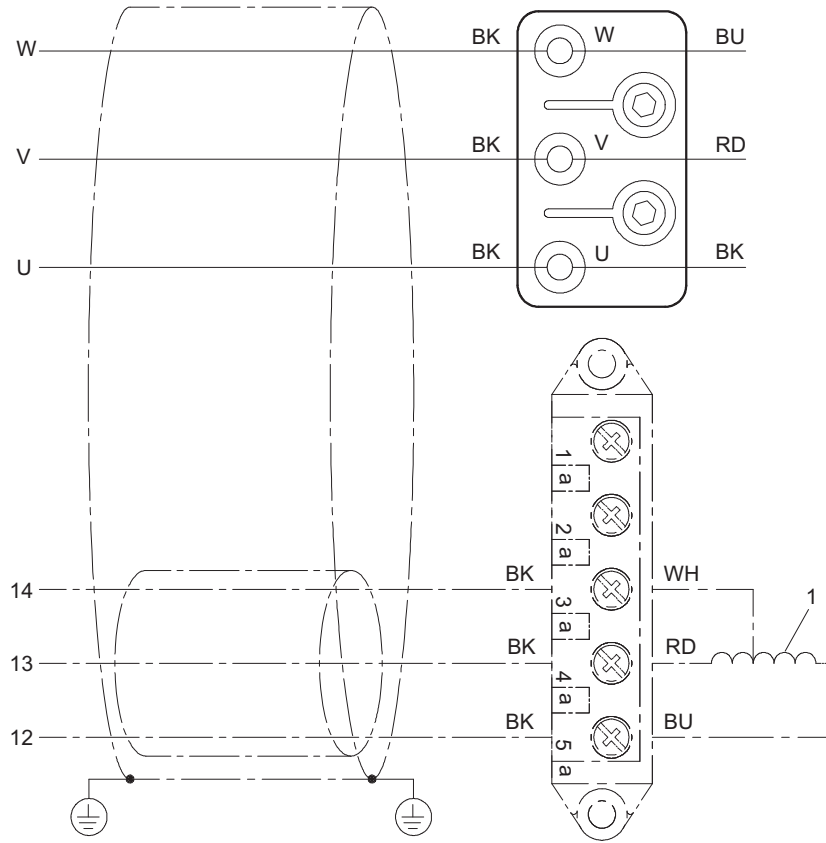

51220AXX

1 = brake coil



**Wiring diagram for RH1M resolver**

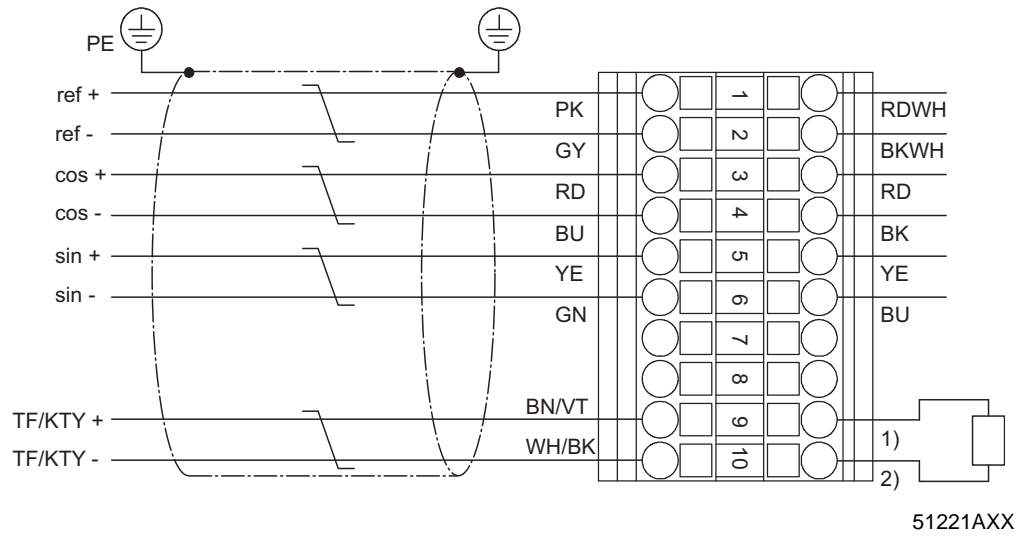

- 1) TF: BKBK / KTY+: RD
- 2) TF: BKBK / KTY-: BU

**Wiring diagram for ES1H / AS1H encoder**

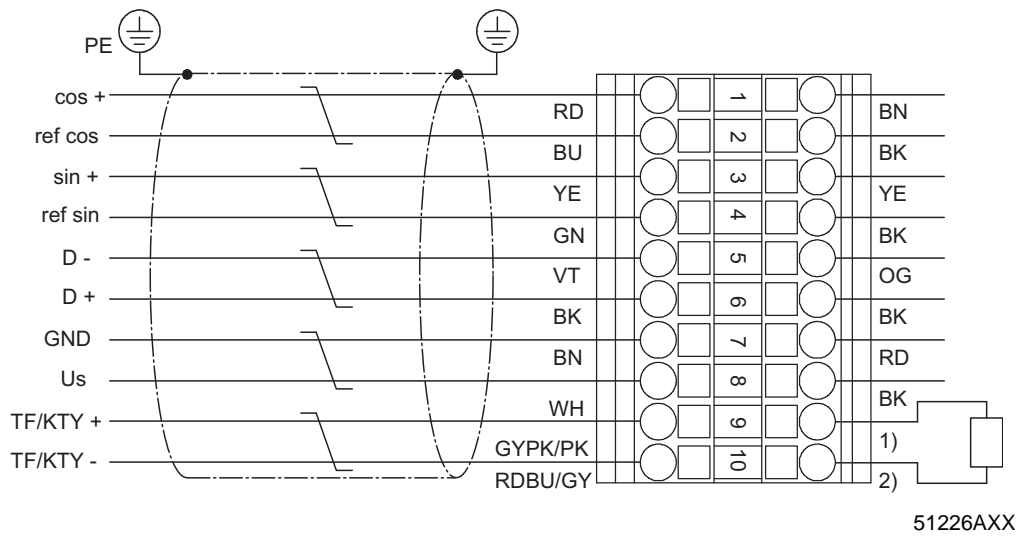

- 1) TF: BKBK / KTY+: RD
- 2) TF: BKBK / KTY-: BU

## 10.7 Wiring diagram for VR forced cooling fan

### Connection via 24 V<sub>DC</sub>

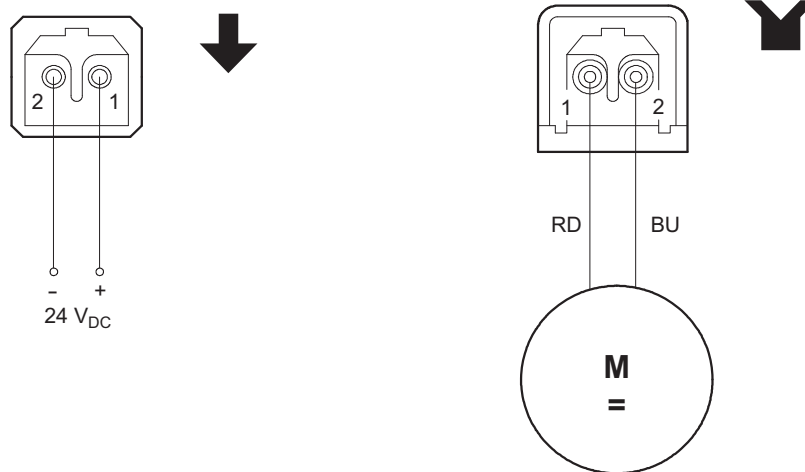

51227AXX

### Connection with UWU51A power supply unit

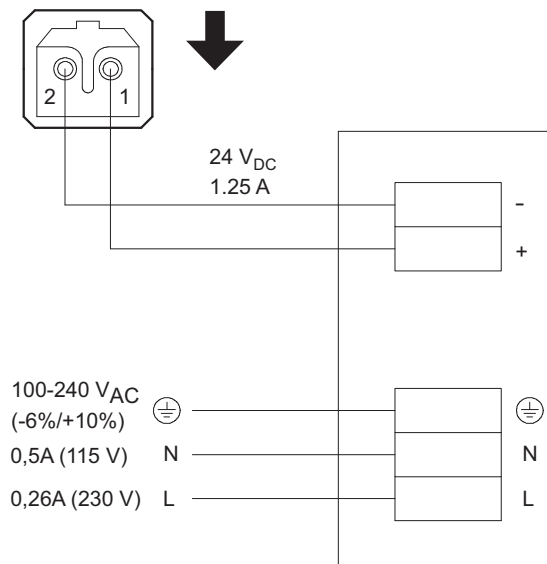

51228AXX



It is essential to check the polarity!



## 11 Index

### 11.1 Index of changes

The following changes and revisions have been added to the previous edition of the CM Synchronous Servomotors operating instructions (publication number: 1052 780x, edition 07/2001):

#### **General**

- The CM112H series has been integrated into the operating instructions.

#### **Section Electrical Installation**

- The connection assignment of resolver, thermal motor protection as well as AS1H and ES1H Hiperface encoders has been revised.
- All connection diagrams of the brake rectifiers have been revised in the section 'Connecting the brake via plug connector'.
- The section 'Connecting the brake via terminal box' has been revised.
- The section 'Mechanical installation of the VR forced cooling fan' has been added to the section 'Optional equipment'.

#### **Section Technical Data**

- The data of the CM112H series have been added to the section 'Technical data'.

#### **Section Appendix**

- The section 'Appendix' has been completely revised.



## Address List

Germany			
<b>Headquarters Production Sales Service</b>	<b>Bruchsal</b>	SEW-EURODRIVE GmbH & Co Ernst-Blickle-Straße 42 D-76646 Bruchsal P.O. Box Postfach 3023 · D-76642 Bruchsal	Tel. +49 (0) 72 51 / 75-0 Fax +49 (0) 72 51 / 75-19 70 <a href="http://www.sew-eurodrive.de">http://www.sew-eurodrive.de</a> <a href="mailto:sew@sew-eurodrive.de">sew@sew-eurodrive.de</a> Service Electronics: Tel. +49 (0) 1 71 / 7 21 07 91 Service Gear Units and Motors: Tel. +49 (0) 1 72 / 7 60 13 77
<b>Assembly Service</b>	<b>Garbsen</b> (near Hannover)	SEW-EURODRIVE GmbH & Co Alte Ricklinger Straße 40-42 D-30823 Garbsen P.O. Box Postfach 110453 · D-30804 Garbsen	Tel. +49 (0) 51 37 / 87 98-30 Fax +49 (0) 51 37 / 87 98-55 <a href="mailto:scm-garbsen@sew-eurodrive.de">scm-garbsen@sew-eurodrive.de</a>
	<b>Kirchheim</b> (near München)	SEW-EURODRIVE GmbH & Co Domagkstraße 5 D-85551 Kirchheim	Tel. +49 (0) 89 / 90 95 52-10 Fax +49 (0) 89 / 90 95 52-50 <a href="mailto:scm-kirchheim@sew-eurodrive.de">scm-kirchheim@sew-eurodrive.de</a>
	<b>Langenfeld</b> (near Düsseldorf)	SEW-EURODRIVE GmbH & Co Siemensstraße 1 D-40764 Langenfeld	Tel. +49 (0) 21 73 / 85 07-30 Fax +49 (0) 21 73 / 85 07-55 <a href="mailto:scm-langenfeld@sew-eurodrive.de">scm-langenfeld@sew-eurodrive.de</a>
	<b>Meerane</b> (near Zwickau)	SEW-EURODRIVE GmbH & Co Dänkritzer Weg 1 D-08393 Meerane	Tel. +49 (0) 37 64 / 76 06-0 Fax +49 (0) 37 64 / 76 06-30 <a href="mailto:scm-meerane@sew-eurodrive.de">scm-meerane@sew-eurodrive.de</a>
Additional addresses for service in Germany provided on request!			
France			
<b>Production Sales Service</b>	<b>Haguenau</b>	SEW-USOCOME 48-54, route de Soufflenheim B. P. 185 F-67506 Haguenau Cedex	Tel. +33 (0) 3 88 73 67 00 Fax +33 (0) 3 88 73 66 00 <a href="http://www.usocomme.com">http://www.usocomme.com</a> <a href="mailto:sew@usocomme.com">sew@usocomme.com</a>
<b>Assembly Sales Service</b>	<b>Bordeaux</b>	SEW-USOCOME Parc d'activités de Magellan 62, avenue de Magellan - B. P. 182 F-33607 Pessac Cedex	Tel. +33 (0) 5 57 26 39 00 Fax +33 (0) 5 57 26 39 09
	<b>Lyon</b>	SEW-USOCOME Parc d'Affaires Roosevelt Rue Jacques Tati F-69120 Vaulx en Velin	Tel. +33 (0) 4 72 15 37 00 Fax + 33 (0) 4 72 15 37 15
	<b>Paris</b>	SEW-USOCOME Zone industrielle 2, rue Denis Papin F-77390 Verneuil l'Etang	Tel. +33 (0) 1 64 42 40 80 Fax +33 (0) 1 64 42 40 88
Additional addresses for service in France provided on request!			
Algeria			
<b>Sales</b>	<b>Alger</b>	Réducom 16, rue des Frères Zagnoun Bellevue El-Harrach 16200 Alger	Tel. +213 (0) 2 82 22 84 Fax +213 (0) 2 82 22 84
Argentina			
<b>Assembly Sales Service</b>	<b>Buenos Aires</b>	SEW EURODRIVE ARGENTINA S.A. Centro Industrial Garin, Lote 35 Ruta Panamericana Km 37,5 1619 Garin	Tel. +54 (0) 33 27 45 72 84 Fax +54 (0) 33 27 45 72 21 <a href="mailto:sewar@sew-eurodrive.com.ar">sewar@sew-eurodrive.com.ar</a>
Australia			
<b>Assembly Sales Service</b>	<b>Melbourne</b>	SEW-EURODRIVE PTY. LTD. 27 Beverage Drive Tullamarine, Victoria 3043	Tel. +61 (0) 3 99 33 10 00 Fax +61 (0) 3 99 33 10 03 <a href="http://www.sew-eurodrive.com.au">http://www.sew-eurodrive.com.au</a> <a href="mailto:enquires@sew-eurodrive.com.au">enquires@sew-eurodrive.com.au</a>
	<b>Sydney</b>	SEW-EURODRIVE PTY. LTD. 9, Sleigh Place, Wetherill Park New South Wales, 2164	Tel. +61 (0) 2 97 25 99 00 Fax +61 (0) 2 97 25 99 05 <a href="mailto:enquires@sew-eurodrive.com.au">enquires@sew-eurodrive.com.au</a>



## Address List

Austria			
<b>Assembly Sales Service</b>	<b>Wien</b>	SEW-EURODRIVE Ges.m.b.H. Richard-Strauss-Strasse 24 A-1230 Wien	Tel. +43 (0) 16 17 55 00-0 Fax +43 (0) 16 17 55 00-30 <a href="http://sew-eurodrive.at">http://sew-eurodrive.at</a> <a href="mailto:sew@sew-eurodrive.at">sew@sew-eurodrive.at</a>
Belgium			
<b>Assembly Sales Service</b>	<b>Brüssel</b>	CARON-VECTOR S.A. Avenue Eiffel 5 B-1300 Wavre	Tel. +32 (0) 10 23 13 11 Fax +32 (0) 10 2313 36 <a href="http://www.caron-vector.be">http://www.caron-vector.be</a> <a href="mailto:info@caron-vector.be">info@caron-vector.be</a>
Brazil			
<b>Production Sales Service</b>	<b>Sao Paulo</b>	SEW-EURODRIVE Brasil Ltda. Avenida Amâncio Gaiolli, 50 Caixa Postal: 201-07111-970 Guarulhos/SP - Cep.: 07251-250	Tel. +55 (0) 11 64 89 91 33 Fax +55 (0) 11 64 80 33 28 <a href="http://www.sew.com.br">http://www.sew.com.br</a> <a href="mailto:sew@sew.com.br">sew@sew.com.br</a>
Additional addresses for service in Brazil provided on request!			
Bulgaria			
<b>Sales</b>	<b>Sofia</b>	BEVER-DRIVE GMBH Bogdanovetz Str.1 BG-1606 Sofia	Tel. +359 (0) 9 29 53 25 65 Fax +359 (0) 9 29 54 93 45 <a href="mailto:bever@mbox.infotel.bg">bever@mbox.infotel.bg</a>
Cameroon			
<b>Sales</b>	<b>Douala</b>	Electro-Services Rue Drouot Akwa B.P. 2024 Douala	Tel. +237 (0) 43 22 99 Fax +237 (0) 42 77 03
Canada			
<b>Assembly Sales Service</b>	<b>Toronto</b>	SEW-EURODRIVE CO. OF CANADA LTD. 210 Walker Drive Bramalea, Ontario L6T3W1	Tel. +1 (0) 905 7 91-15 53 Fax +1 (0) 905 7 91-29 99 <a href="http://www.sew-eurodrive.ca">http://www.sew-eurodrive.ca</a> <a href="mailto:l.reynolds@sew-eurodrive.ca">l.reynolds@sew-eurodrive.ca</a>
	<b>Vancouver</b>	SEW-EURODRIVE CO. OF CANADA LTD. 7188 Honeyman Street Delta. B.C. V4G 1 E2	Tel. +1 (0) 604 9 46-55 35 Fax +1 (0) 604 946-2513 <a href="mailto:b.wake@sew-eurodrive.ca">b.wake@sew-eurodrive.ca</a>
	<b>Montreal</b>	SEW-EURODRIVE CO. OF CANADA LTD. 2555 Rue Leger Street LaSalle, Quebec H8N 2V9	Tel. +1 (0) 514 3 67-11 24 Fax +1 (0) 514 3 67-36 77 <a href="mailto:a.peluso@sew-eurodrive.ca">a.peluso@sew-eurodrive.ca</a>
Additional addresses for service in Canada provided on request!			
Chile			
<b>Assembly Sales Service</b>	<b>Santiago de Chile</b>	SEW-EURODRIVE CHILE LTDA. Las Encinas 1295 Parque Industrial Valle Grande LAMP RCH-Santiago de Chile P.O. Box Casilla 23 Correo Quilicura - Santiago - Chile	Tel. +56 (0) 27 57 70 00 Fax +56 (0) 27 57 70 01 <a href="mailto:sewsales@entelchile.net">sewsales@entelchile.net</a>
China			
<b>Production Assembly Sales Service</b>	<b>Tianjin</b>	SEW-EURODRIVE (Tianjin) Co., Ltd. No. 46, 7th Avenue, TEDA Tianjin 300457	Tel. +86 (0) 22 25 32 26 12 Fax +86 (0) 22 25 32 26 11 <a href="http://www.sew.com.cn">http://www.sew.com.cn</a>
<b>Assembly Sales Service</b>	<b>Suzhou</b>	SEW-EURODRIVE (Suzhou) Co., Ltd. 333, Suhong Middle Road Suzhou Industrial Park Jiangsu Province, 215021 P. R. China	Tel. +86 (0) 5 12 - 62 58 17 81 Fax +86 (0) 5 12 - 62 58 17 83 <a href="mailto:suzhou@sew.com.cn">suzhou@sew.com.cn</a>



Colombia			
<b>Assembly Sales Service</b>	<b>Bogotá</b>	SEW-EURODRIVE COLOMBIA LTDA. Calle 22 No. 132-60 Bodega 6, Manzana B Santafé de Bogotá	Tel. +57 (0) 15 47 50 50 Fax +57 (0) 15 47 50 44 sewcol@andinet.com
Croatia			
<b>Sales Service</b>	<b>Zagreb</b>	KOMPEKS d. o. o. PIT Erdödy 4 II HR 10 000 Zagreb	Tel. +385 (0) 14 61 31 58 Fax +385 (0) 14 61 31 58 kompeks@net.hr
Czech Republic			
<b>Sales</b>	<b>Praha</b>	SEW-EURODRIVE CZ S.R.O. Business Centrum Praha Luná 591 CZ-16000 Praha 6 - Vokovice	Tel. +420 (0) 2 20 12 12 34 + 2 20 12 12 36 Fax +420 (0) 2 20 12 12 37 <a href="http://www.sew-eurodrive.cz">http://www.sew-eurodrive.cz</a> sew@sew-eurodrive.cz
Denmark			
<b>Assembly Sales Service</b>	<b>Kopenhagen</b>	SEW-EURODRIVEA/S Geminivej 28-30, P.O. Box 100 DK-2670 Greve	Tel. +45 (0) 43 95 8500 Fax +45 (0) 43 95 8509 <a href="http://www.sew-eurodrive.dk">http://www.sew-eurodrive.dk</a> sew@sew-eurodrive.dk
Estonia			
<b>Sales</b>	<b>Tallin</b>	ALAS-KUUL AS Paldiski mnt.125 EE 0006 Tallin	Tel. +372 (0) 6 59 32 30 Fax +372 (0) 6 59 32 31
Finland			
<b>Assembly Sales Service</b>	<b>Lahti</b>	SEW-EURODRIVE OY Vesimäentie 4 FIN-15860 Hollola 2	Tel. +358 (0) 3 589 300 Fax +358 (0) 3 780 6211 <a href="http://www.sew-eurodrive.fi">http://www.sew-eurodrive.fi</a> sew@sew-eurodrive.fi
Gabon			
<b>Sales</b>	<b>Libreville</b>	Electro-Services B.P. 1889 Libreville	Tel. +241 (0) 73 40 11 Fax +241 (0) 73 40 12
Great Britain			
<b>Assembly Sales Service</b>	<b>Normanton</b>	SEW-EURODRIVE Ltd. Beckbridge Industrial Estate P.O. Box No.1 GB-Normanton, West- Yorkshire WF6 1QR	Tel. +44 (0) 19 24 89 38 55 Fax +44 (0) 19 24 89 37 02 <a href="http://www.sew-eurodrive.co.uk">http://www.sew-eurodrive.co.uk</a> info@sew-eurodrive.co.uk
Greece			
<b>Sales Service</b>	<b>Athen</b>	Christ. Boznos & Son S.A. 12, Mavromichali Street P.O. Box 80136, GR-18545 Piraeus	Tel. +30 (0) 21 04 22 51 34 Fax +30 (0) 21 04 22 51 59 <a href="http://www.boznos.gr">http://www.boznos.gr</a> Boznos@otenet.gr
Hong Kong			
<b>Assembly Sales Service</b>	<b>Hong Kong</b>	SEW-EURODRIVE LTD. Unit No. 801-806, 8th Floor Hong Leong Industrial Complex No. 4, Wang Kwong Road Kowloon, Hong Kong	Tel. +852 (0) 2-7 96 04 77 + 79 60 46 54 Fax +852 (0) 2-7 95-91 29 sew@sewhk.com
Hungary			
<b>Sales Service</b>	<b>Budapest</b>	SEW-EURODRIVE Kft. H-1037 Budapest Kunigunda u. 18	Tel. +36 (0) 1 437 06 58 Fax +36 (0) 1 437 06 50 sew-eurodrive.voros@matarnet.hu



## Address List

India			
<b>Assembly Sales Service</b>	<b>Baroda</b>	SEW-EURODRIVE India Pvt. Ltd. Plot No. 4, Gidc Por Ramangamdi · Baroda - 391 243 Gujarat	Tel. +91 (0) 265-283 10 21 Fax +91 (0) 265-283 10 87 sew.baroda@gecsl.com
Ireland			
<b>Sales Service</b>	<b>Dublin</b>	Alperston Engineering Ltd. 48 Moyle Road Dublin Industrial Estate Glasnevin, Dublin 11	Tel. +353 (0) 18 30 62 77 Fax +353 (0) 18 30 64 58
Italy			
<b>Assembly Sales Service</b>	<b>Milano</b>	SEW-EURODRIVE di R. Blickle & Co.s.a.s. Via Bernini,14 I-20020 Solaro (Milano)	Tel. +39 (0) 2 96 98 01 Fax +39 (0) 2 96 79 97 81 sewit@sew-eurodrive.it
Ivory Coast			
<b>Sales</b>	<b>Abidjan</b>	SICA Ste industrielle et commerciale pour l'Afrique 165, Bld de Marseille B.P. 2323, Abidjan 08	Tel. +225 (0) 25 79 44 Fax +225 (0) 25 84 36
Japan			
<b>Assembly Sales Service</b>	<b>Toyoda-cho</b>	SEW-EURODRIVE JAPAN CO., LTD 250-1, Shimoman-no, Toyoda-cho, Iwata gun Shizuoka prefecture, 438-0818	Tel. +81 (0) 53 83 7 3811-13 Fax +81 (0) 53 83 7 3814 sewjapan@sew-eurodrive.co.jp
Korea			
<b>Assembly Sales Service</b>	<b>Ansan-City</b>	SEW-EURODRIVE KOREA CO., LTD. B 601-4, Banweol Industrial Estate Unit 1048-4, Shingil-Dong Ansan 425-120	Tel. +82 (0) 3 14 92-80 51 Fax +82 (0) 3 14 92-80 56 master@sew-korea.co.kr
Lebanon			
<b>Sales</b>	<b>Beirut</b>	Gabriel Acar & Fils sarl B. P. 80484 Bourj Hammoud, Beirut	Tel. +961 (0) 1 49 47 86 +961 (0) 1 49 82 72 +961 (0) 3 27 45 39 Fax +961 (0) 1 49 49 71 gacar@beirut.com
Luxembourg			
<b>Assembly Sales Service</b>	<b>Brüssel</b>	CARON-VECTOR S.A. Avenue Eiffel 5 B-1300 Wavre	Tel. +352 (0) 10 23 13 11 Fax +352 (0) 10 2313 36 <a href="http://www.caron-vector.be">http://www.caron-vector.be</a> info@caron-vector.be
Macedonia			
<b>Sales</b>	<b>Skopje</b>	SGS-Skopje / Macedonia "Teodosij Sinactaski" 66 91000 Skopje / Macedonia	Tel. +389 (0) 9 91 38 43 90 Fax +389 (0) 9 91 38 43 90 sgs@mol.com.mk
Malaysia			
<b>Assembly Sales Service</b>	<b>Johore</b>	SEW-EURODRIVE SDN BHD No. 95, Jalan Seroja 39, Taman Johor Jaya 81000 Johor Bahru, Johor West Malaysia	Tel. +60 (0) 73 54 57 07 + 73 54 94 09 Fax +60 (0) 73 5414 04 kchtan@pd.jaring.my
Morocco			
<b>Sales</b>	<b>Casablanca</b>	S. R. M. Société de Réalisations Mécaniques 5, rue Emir Abdelkader 05 Casablanca	Tel. +212 (0) 2 61 86 69 + 61 86 70 + 61 86 71 Fax +212 (0) 2 62 15 88 srm@marocnet.net.ma





Netherlands			
<b>Assembly Sales Service</b>	<b>Rotterdam</b>	VECTOR Aandrijftechniek B.V. Industrieweg 175 NL-3044 AS Rotterdam Postbus 10085 NL-3004 AB Rotterdam	Tel. +31 (0) 10 44 63 700 Fax +31 (0) 10 41 55 552 <a href="http://www.vector.nu">http://www.vector.nu</a> info@vector.nu
New Zealand			
<b>Assembly Sales Service</b>	<b>Auckland</b>	SEW-EURODRIVE NEW ZEALAND LTD. P.O. Box 58-428 82 Greenmount drive East Tamaki Auckland	Tel. +64 (0) 9-2 74 56 27 Fax +64 (0) 9-2 74 01 65 sales@sew-eurodrive.co.nz
	<b>Christchurch</b>	SEW-EURODRIVE NEW ZEALAND LTD. 10 Settlers Crescent, Ferrymead Christchurch	Tel. +64 (0) 3-3 84 62 51 Fax +64 (0) 3-3 85 64 55 sales@sew-eurodrive.co.nz
Norway			
<b>Assembly Sales Service</b>	<b>Moss</b>	SEW-EURODRIVE A/S Solgaard skog 71 N-1599 Moss	Tel. +47 (0) 69 2410 20 Fax +47 (0) 69 2410 40 sew@sew-eurodrive.no
Peru			
<b>Assembly Sales Service</b>	<b>Lima</b>	SEW DEL PERU MOTORES REDUCTORES S.A.C. Los Calderos # 120-124 Urbanizacion Industrial Vulcano, ATE, Lima	Tel. +51 (0) 13 49 52 80 Fax +51 (0) 13 49 30 02 sewperu@terra.com.pe
Poland			
<b>Assembly Sales Service</b>	<b>Lodz</b>	SEW-EURODRIVE Polska Sp.z.o.o. ul. Techniczna 5 PL-92-518 Lodz	Tel. +48 (0) 4 26 77 10 90 Fax +48 (0) 4 26 77 10 99 <a href="http://www.sew-eurodrive.pl">http://www.sew-eurodrive.pl</a> sew@sew-eurodrive.pl
Portugal			
<b>Assembly Sales Service</b>	<b>Coimbra</b>	SEW-EURODRIVE, LDA. Apartado 15 P-3050-901 Mealhada	Tel. +351 (0) 2 31 20 96 70 Fax +351 (0) 2 31 20 36 85 <a href="http://www.sew-eurodrive.pt">http://www.sew-eurodrive.pt</a> infosew@sew-eurodrive.pt
Romania			
<b>Sales Service</b>	<b>Bucuresti</b>	Sialco Trading SRL str. Madrid nr.4 71222 Bucuresti	Tel. +40 (0) 2 12 30 13 28 Fax +40 (0) 2 12 30 71 70 sialco@sialco.ro
Russia			
<b>Sales</b>	<b>St. Petersburg</b>	ZAO SEW-EURODRIVE P.O. Box 263 RUS-195220 St. Petersburg	Tel. +7 (0) 812 5 35 71 42 + 812 5 35 04 30 Fax +7 (0) 812 5 35 22 87 sew@sew-eurodrive.ru
Senegal			
<b>Sales</b>	<b>Dakar</b>	SENEMECA Mécanique Générale Km 8, Route de Rufisque B.P. 3251, Dakar	Tel. +221 (0) 849 47 70 Fax +221 (0) 849 47 71 senemeca@sentoo.sn
Singapore			
<b>Assembly Sales Service</b>	<b>Singapore</b>	SEW-EURODRIVE PTE. LTD. No 9, Tuas Drive 2 Jurong Industrial Estate Singapore 638644	Tel. +65 (0) 68 62 17 01 ... 17 05 Fax +65 (0) 68 61 28 27 Telex 38 659 sales@sew-eurodrive.com.sg
Slovenia			
<b>Sales Service</b>	<b>Celje</b>	Pakman - Pogonska Tehnika d.o.o. Ul. XIV. divizije 14 SLO – 3000 Celje	Tel. +386 (0) 3 490 83 20 Fax +386 (0) 3 490 83 21 pakman@siol.net



## Address List

South Africa			
Assembly Sales Service	<b>Johannesburg</b>	SEW-EURODRIVE (PROPRIETARY) LIMITED Eurodrive House Cnr. Adcock Ingram and Aerodrome Roads Aeroton Ext. 2 Johannesburg 2013 P.O.Box 90004 Bertsham 2013	Tel. + 27 (0) 11 248 70 00 Fax +27 (0) 11 494 23 11 ljansen@sew.co.za
	<b>Capetown</b>	SEW-EURODRIVE (PROPRIETARY) LIMITED Rainbow Park Cnr. Racecourse & Omuramba Road Montague Gardens Cape Town P.O.Box 36556 Chempet 7442 Cape Town	Tel. +27 (0) 21 552 98 20 Fax +27 (0) 21 552 98 30 Telex 576 062 dswanepoel@sew.co.za
	<b>Durban</b>	SEW-EURODRIVE (PROPRIETARY) LIMITED 2 Monaceo Place Pinetown Durban P.O. Box 10433, Ashwood 3605	Tel. +27 (0) 31 700 34 51 Fax +27 (0) 31 700 38 47 dtait@sew.co.za
Spain			
Assembly Sales Service	<b>Bilbao</b>	SEW-EURODRIVE ESPAÑA, S.L. Parque Tecnológico, Edificio, 302 E-48170 Zamudio (Vizcaya)	Tel. +34 (0) 9 44 31 84 70 Fax +34 (0) 9 44 31 84 71 sew.spain@sew-eurodrive.es
Sweden			
Assembly Sales Service	<b>Jönköping</b>	SEW-EURODRIVE AB Gnejsvägen 6-8 S-55303 Jönköping Box 3100 S-55003 Jönköping	Tel. +46 (0) 36 34 42 00 Fax +46 (0) 36 34 42 80 <a href="http://www.sew-eurodrive.se">http://www.sew-eurodrive.se</a> info@sew-eurodrive.se
Switzerland			
Assembly Sales Service	<b>Basel</b>	Alfred Imhof A.G. Jurastrasse 10 CH-4142 Münchenstein bei Basel	Tel. +41 (0) 6 14 17 17 17 Fax +41 (0) 6 14 17 17 00 <a href="http://www.imhof-sew.ch">http://www.imhof-sew.ch</a> info@imhof-sew.ch
Thailand			
Assembly Sales Service	<b>Chon Buri</b>	SEW-EURODRIVE (Thailand) Ltd. Bangpakong Industrial Park 2 700/456, Moo.7, Tambol Donhuaroh Muang District Chon Buri 20000	Tel. +66 (0) 38 45 42 81 Fax +66 (0) 38 45 42 88 sewthailand@sew-eurodrive.co.th
Tunisia			
Sales	<b>Tunis</b>	T. M.S. Technic Marketing Service 7, rue Ibn El Heithem Z.I. SMMT 2014 Mégrine Erriadh	Tel. +216 (0) 1 43 40 64 + 1 43 20 29 Fax +216 (0) 1 43 29 76
Turkey			
Assembly Sales Service	<b>Istanbul</b>	SEW-EURODRIVE Hareket Sistemleri Sirketi Bagdat Cad. Koruma Cikmazi No. 3 TR-81540 Maltepe ISTANBUL	Tel. +90 (0) 216 4 41 91 63 + 216 4 41 91 64 + 216 3 83 80 14 Fax +90 (0) 216 3 05 58 67 sew@sew-eurodrive.com.tr
USA			
Production Assembly Sales Service	<b>Greenville</b>	SEW-EURODRIVE INC. 1295 Old Spartanburg Highway P.O. Box 518 Lyman, S.C. 29365	Tel. +1 (0) 864 4 39 75 37 Fax Sales +1 (0) 864 439-78 30 Fax Manuf. +1 (0) 864 4 39-99 48 Fax Ass. +1 (0) 864 4 39-05 66 Telex 805 550 <a href="http://www.seweurodrive.com">http://www.seweurodrive.com</a> cslyman@seweurodrive.com



<b>USA</b>			
<b>Assembly Sales Service</b>	<b>San Francisco</b>	SEW-EURODRIVE INC. 30599 San Antonio St. Hayward, California 94544-7101	Tel. +1 (0) 510 4 87-35 60 Fax +1 (0) 510 4 87-63 81 cshayward@seweurodrive.com
	<b>Philadelphia/PA</b>	SEW-EURODRIVE INC. Pureland Ind. Complex 2107 High Hill Road, P.O. Box 481 Bridgeport, New Jersey 08014	Tel. +1 (0) 856 4 67-22 77 Fax +1 (0) 856 4 67-37 92 csbridgeport@seweurodrive.com
	<b>Dayton</b>	SEW-EURODRIVE INC. 2001 West Main Street Troy, Ohio 45373	Tel. +1 (0) 9 37 3 35-00 36 Fax +1 (0) 9 37 4 40-37 99 cstroy@seweurodrive.com
	<b>Dallas</b>	SEW-EURODRIVE INC. 3950 Platinum Way Dallas, Texas 75237	Tel. +1 (0) 214 3 30-48 24 Fax +1 (0) 214 3 30-47 24 csdallas@seweurodrive.com
Additional addresses for service in the USA provided on request!			
<b>Venezuela</b>			
<b>Assembly Sales Service</b>	<b>Valencia</b>	SEW-EURODRIVE Venezuela S.A. Av. Norte Sur No. 3, Galpon 84-319 Zona Industrial Municipal Norte Valencia, Estado Carabobo	Tel. +58 (0) 241 8 32 98 04 Fax +58 (0) 241 8 38 62 75 sewventas@cantv.net sewfinanzas@cantv.net

SEW-EURODRIVE GmbH & Co KG · P.O. Box 3023 · D-76642 Bruchsal/Germany  
Phone +49 7251 75-0 · Fax +49 7251 75-1970  
<http://www.sew-eurodrive.com> · [sew@sew-eurodrive.com](mailto:sew@sew-eurodrive.com)

**SEW**  
**EURODRIVE**

