

GMN

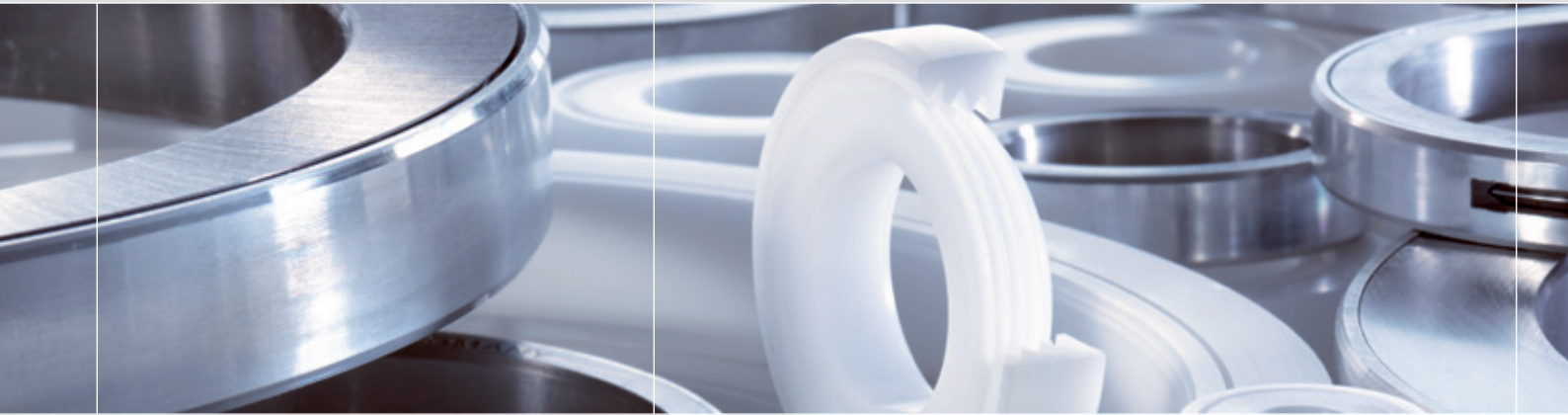

Non-Contact Seals



Index:

Non-contact seals

- Introduction
- Classification
- Comparisons to contact seals
- Need to know information
- Function
- Non-Contact Seal benefits
- Application examples
- Characteristics of sealing system
- Parameters of a non-contact seals

Pages 4–13

GMN

Labyrinth Metal Seals

- Technical data
- Product characteristics
- Dimension table
- Specials - width, material, etc.
- Dimensional tolerances

Pages 14–19



GMN
Labyrinth Plastic Seals

- Technical data
- Product characteristics
- Dimension table
- Specials - width, material, etc.
- Dimensional tolerances

Pages 20–25

Installation

- General information
- Surrounding construction
- Standard installation
- Installation methods
- Specific installation examples
- Seals with drain grooves
- Additional aspects to consider

Pages 26–31

GMN

- Product range - overview
- DIN tolerances
- Index

Pages 32–34



GMN Non-Contact Seals

The machine tool industry and its end users are continuously demanding the utmost in quality in every aspect of their machine. Highly specialized components are resulting in shorter process time, higher rotating speed, flexible material characteristics and a huge range of operating conditions. Simultaneously, new energy-saving solutions and maintenance-free characteristics are increasing economic efficiency of modern machine systems.



Based on decades of experience, GMN has specialized in producing extremely high quality machine tool components. Through this strategy, GMN manufactures a wide range of standard non-contact seals and customized solutions.

The frictionless, no-wear characteristics of GMN Non-Contact Seals offer effective, economical and ecological solutions for modern applications in and outside of the machine tool industry.

Seals Classification

Classification

Varying industrial processes and demands require specialized sealing systems which could be classified into several product groups.

GMN Non-Contact Seals

GMN provides efficient, economical, quality sealing components made of metal or plastic for concentric rotating parts.

Seals (Classification)					
Dynamic seals				Static seals	
Linear movement		Rotary movement			
Rod, piston, linear guided seals		Shaft seals			
Non-Contact	Contact	Non-Contact	Contact	Non-Contact	Contact
Gap Special solutions Sealing air	Grooved ring Wiper ring Edge sealing ring Compact seal	GMN Labyrinth Seal - Metal - Plastic Special solutions	Felt ring Compression gland Slide ring seal Radial shaft seal	Ventilation	O-Ring Sealing mass Bellow-type seal Profile seal Flat seal Membrane seal High pressure seal Cutting ring seal

Non-Contact Seals vs. Contact Seals

The design of GMN Non-Contact Seals offers – compared to conventional contact seals – operation without any friction, an essential advantage for many seal applications.

Comparisons of Non-Contact Seals vs. Contact Seals

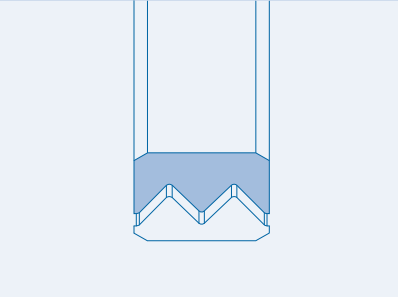
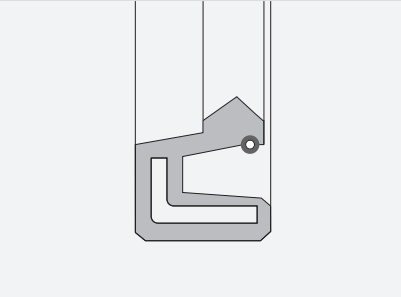
	 GMN Non-Contact Seals	 Contact Seals
Seal wear	Absolutely no wear of any component Minimal maintenance	Rubbing wear due to relative movement (rotation) at the sealing lip
Power loss	No power loss Increases the possibility for smaller drives	Power loss due to friction
Speed limit	At high speed rotation only, the inner-ring can lift-off from the shaft due to its weight combating centrifugal forces	Limited applications for high speed rotation due to the increased wear
Contamination / abrasion	Absolute no contamination A key factor for food, electro-technical and electronic industries	Micro-wear due to friction Wear may turn into contaminant
Lifetime	Unlimited lifetime	Lifetime/function is limited due to wear
Lubrication of the seal	Not necessary	Often recommended
Mating components - Hardening and grinding	No hardening or grinding of the mating parts Simple turning quality (IT6) is sufficient	Shaft must be hardened and ground in most applications
Increase of temperature	No increase of temperature	Increase of temperature due to friction
Temperature range	High operating range Due to the steel and aluminium construction; 392° F [200° C] Plastic (POM) is rated to 140° F [60° C]	Narrow operating range Because of materials such as various rubbers and elastomeres.

Non-Contact Seals Basics

In correlation with the application's design, non-contact seals also:

- Protect/shield inner workings of the application
- Throttling/switching
- Back transport of application medium(s)
- Optional draining within the seal design

The seal itself as well as the specific design encompassing the seal satisfies only parts of the sealing requirement.

The maximum efficiency of a GMN labyrinth seal is achieved with an optimised interaction of the seal-component and the surrounding construction/design.

Sealing function at machine standstill

The functions of protecting, shielding, throttling and switching are effective even when the shaft stands still. The seal functions of back transport and draining require the shaft to be rotating.

Functions of the seal and the surrounding construction in an application

Components encompassing the seal



Protecting/
Shielding

The sealing gap is protected against direct contamination with a customized housing/shaft design. Specifically, the design in front of the seal's entrance area is important to the seal's efficiency.

GMN seal component



Throttling/
Switching

The tight sealing gap throttles (reduces) the flow and minimizes possible penetration by any contamination. The labyrinth geometry creates an efficient barrier against liquids and dust.

GMN seal component



Back transport
of application
medium(s)

If heavy splashing liquids are penetrating the gap, drain grooves in the outer ring and a ring groove inside the housing can provide back transport when the shaft is rotating. This is commonly used for heavy coolant or oil splashing where saving the medium is key to the application (M Type seal).

Surrounding components to the seal



Draining

Grooves in the housing will effectively drain the medium. GMN engineers are available to help with waste gate design. This groove design is essential to the optimization of a GMN M Type seal.

Function

GMN produces non-contact seals in two different types:

GMN Labyrinth Metal Seals are made from two different materials with different stiffness. A special production process creates a tight horizontal labyrinth gap between the steel inner ring and the aluminium outer ring.

The **inner and outer rings of GMN Labyrinth Plastic Seals** are made from the same material (POM). The gap within the labyrinth geometry has a conical design.



GMN Non-Contact Seal
(metal)



GMN Non-Contact Seal
(plastic)

Gap height

The theory of non-contact seals is based on the gap height between inner and outer rings.

The tighter the gap height is on the seal (reduction in ring gap area), diminishes the opportunity for any contaminant entry.

Depending on amount, direction and speed (intensity) of the contamination, an additional protection against direct splashing liquids is recommended.

As an additional supporting effect inherent in a non-contact seal, tight gaps create an air cushion inside the gap. This air cushion increases in correlation to rotational speed.

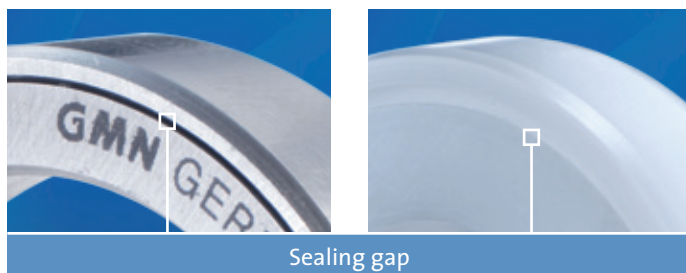

Sealing gap

With the constant gap height of only 0.2 to 0.5 mm. **The complete product line of GMN Labyrinth Metal Seals** achieves the highest efficiency.

Plastic seals have a varying internal gap height due to the asymmetric labyrinth geometry.

The minimal gap height of approximately 0.5 mm also guarantees the highest efficiency.

Labyrinth

The labyrinth geometry acts as a barrier against any liquids or dust. Particles entering the Labyrinth seal bump against the labyrinth, therefore any media is slowed. The shifts in direction inside the labyrinth make passing the seal almost impossible.

Metal seals provide 1 to 4 labyrinth steps (depending on size) in a minimized space. GMN's proprietary manufacturing process guarantees 100% conformity of inner- and outer ring's labyrinth geometry to each other.

Plastic seals are providing 2 to 4 labyrinths steps depending on size. With this type, the conical gap design increases sealing efficiency due to centrifugal forces of rotation.

Penetrated media is transported back to the larger gap diameter when the shaft is rotating. The larger gap diameter always faces the contamination.



Labyrinth (metal)



Labyrinth (plastic)

In case of heavy splashing liquids, type M and SA with drain grooves are preferred.



Drain groove (metal)
Type M



Drain groove (plastic)
Type SA

GMN Non-Contact Seals Benefits and applications

Benefits

The specific design of GMN Labyrinth Seals allows operation without any friction. Many different applications are taking advantage of this major benefit:

Technical benefits

- No wear
- Rated for high rotating speeds
- Sealing efficiency is independent from direction of rotation
- No abrasion, no contamination

Thermal benefits

- No frictional heat increase
- No thermal effects to the surrounding application

Functional benefits

- Maintenance free
- Constant sealing efficiency during operation
- No adjustment required
- No lubrication required (approved for dry operation)

Economic benefits

- No hardening or grinding of mating parts
- Unlimited lifetime – no replacement due to the Non-Contact design
- Cost saving component instead of expensive self made labyrinth
- Less maintenance results in higher machine yield
- No frictional loss results in reduced demand to engine output

Ecological benefits

- Operation without friction saves energy

Applications

- **High-speed**
(no-wear operation)
- **Sealing against dust**
(Pre-greased GMN Labyrinth Seal made of plastic)
- **High cleanliness**
(Freedom from any wear)
- **Positioning without resistance**
(No opposing forces during operation)
- **Protection for lip seals**
(Guarding against wear from chips and abrasive particles)

Practical examples



Textile / paper industry

Sealing against dust

The sealing of fine textile fibres is a challenge for any sealing system. Fibres and micro-fibres have the tendency to cling to the sealing gap of a lip seal. As a result, friction and wear are increasing with use. With time, the fibres are making their way to the bearings. In applications like this, pre-greased GMN Labyrinth Seals made of plastic are providing an established, proven alternative.

Examples in the textile industry are; carding engines, spinning machines, coiling machines, mechanical looms, knitting machines, cutting machines, etc..

Similar applications can be found in the paper industry. Pre-greased GMN Labyrinth Seals made of plastic are providing high efficiency sealing alternatives against fine paper dust.



Machine tool industry, spindle heads

High-speed applications

The maximum speed of contact seals is limited because of temperature, wear and resultant life expectancy.

GMN Non-Contact Seals protect spindle bearings against cooling fluid and metal/wood chips. They are operating free from wear and any frictional contact. Unlimited life, no temperature increase from operation, freedom from maintenance and no loss of power provide a perfect economic solution.

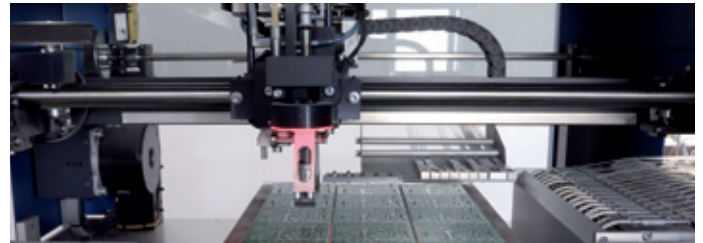

Highly accurate positioning

Positioning without resistance

Sophisticated optical or magnetic systems have to be reliably protected against any external contamination.

Encoders are exposed to high dynamic accelerations at an already high speed. With GMN Non-Contact Seals encoders could be positioned without resistance to the highest accuracy.

This is a requirement of many high-tech performance applications.



Food / chemical / electronic industries

High cleanliness

Cleanliness and freedom from wear is essential in the food industry. Every contact seal is operating with some kind of relative movement between two different components being in contact continuously. With this friction, small amounts of wear (i.e. rubber material) have to be accepted, it could never be fully excluded. In the worst case, this wear could contaminate food.

A Non-Contact Seal is absolutely free from any friction contact and free from any wear. There is no risk for any kind of contamination. An additional advantage of our GMN Labyrinth Plastic Seals is the resistance against many acids (i.e. lactic acid), chemicals (cleaning processes) and fungi; the material (POM) is already FDA-approved.

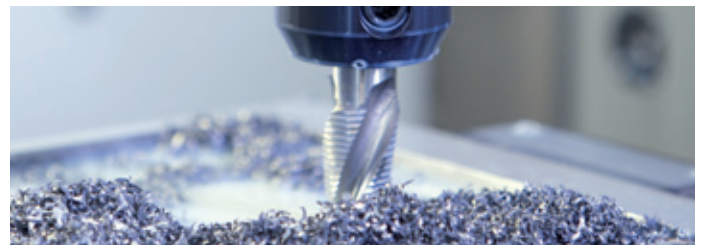

Sealing against chips and abrasive contaminations

Protection for a lip seal

Lip Seal life is extremely limited with contact of chips and abrasive particles. This contact greatly accelerates the wear of the rubber material.

An optimal solution is the combination of both seal systems: In a first step the GMN Non-Contact Seal keeps chips and abrasive particles away from the lip seal. In this scenario the contact seal is protected and the lifetime of the complete sealing system increases greatly.

The additional investment for the GMN Non-Contact Seal is minimal compared to the lost time to repair and/or replace worn seals.

Characteristics of sealing systems

The performance of any seal in various machines is extremely important to the life and efficiency of the complete system.

Because of this, GMN prefers to help customers early in the design phase to ensure that everything will perform as planned and the correct design choices are made.

Different applications require specialized and individual solutions; there is a large variety of products on the market.

The table below includes some general information to help find the best seal for your application.

In many cases the combination of different sealing systems provides the perfect solution. An additional GMN Non-Contact Seal could protect a standard contact seal against chips to increase the life-time of the complete sealing system.

	GMN Metal	GMN Plastic	Shield	Radial shaft seal	Sliding shield	Felt ring	Packed gland	Face seal
Suitable for high rotational speed	++	++	++	+-	+	--	-	++
Suitable against splashing liquids	++	++	-	++	++	++	+-	+-
Suitable against dust	+	++	-	-	+	+	+-	+-
Suitable against water	+-	++	+-	+	+-	++	++	++
Suitable against chemicals	-	++	-	+-	+-	+-	+	++
Suitable for food industry	--	++	-	+-	+-	-	+-	+
Suitable against liquid levels	--	--	--	+	+-	+-	+	++
Suitable against pressure differentials	--	--	--	+-	-	-	+	++
Suitable in high temperature applications	++	-	+-	+	+	-	+	++
Power efficiency	++	++	++	+-	+	-	--	--
Life time	++	++	++	+-	++	-	--	+-
Thermal effects to surrounding construction	no	no	no	low	low	middle	high	high
Requirements to the mating parts	low	low	middle	middle	low	middle	high	high
Maintenance	no	no	no	middle	low	low	high	middle

Limits of use

GMN Non-Contact Seals are providing solutions for a wide field of applications. However, in certain cases the use of GMN seals is also limited.

Liquid levels and pressure differentials

The design of a GMN Non-Contact Seal requires a gap between the outer and the inner ring. With this gap liquid levels and any difference of pressure could be reduced, but not sealed.

Speed limit

With increasing rotational speed the press-fit inner ring on the shaft has the tendency to lift-off due to centrifugal forces (lift-off speed). Most applications are far below this speed limit.

In certain cases the speed limit could be increased with increased press fit. We recommend contacting a GMN engineer when you feel that this may happen in your application.

Speed limit of GMN Non-Contact Seals

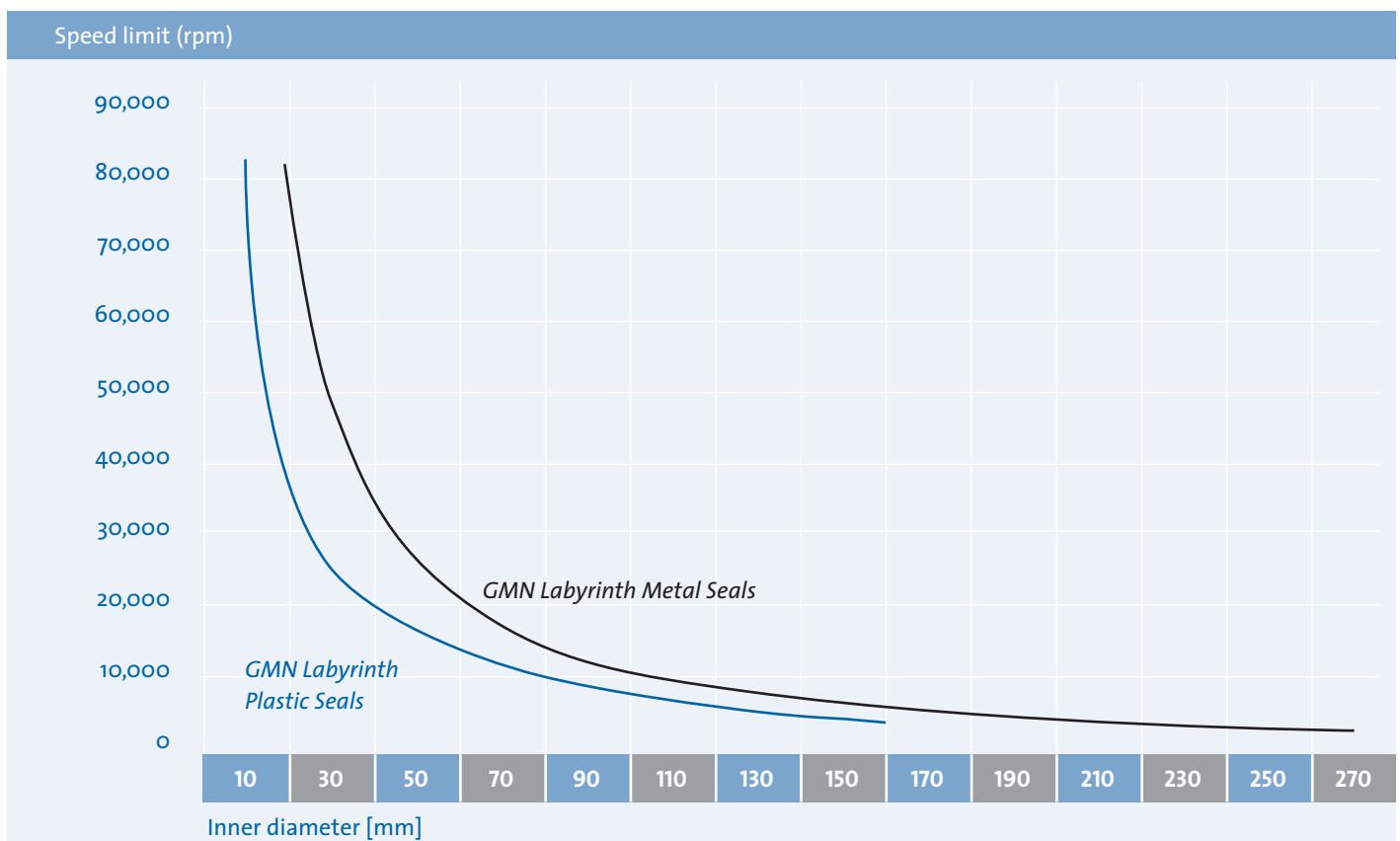

The maximum circumferential speed is (depending on the size) $v = 35-60$ m/s for GMN Labyrinth Metal Seals and $v = 45-70$ m/s for GMN Labyrinth Plastic Seals.

GMN Labyrinth Metal Seals Type L and M

Type L

Against splashing liquids for rotating shafts and housings



Type M with drain grooves

Against heavy splashing liquids (optimized back transport) for rotating shafts only

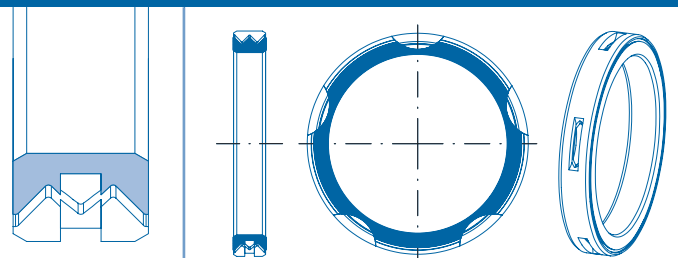
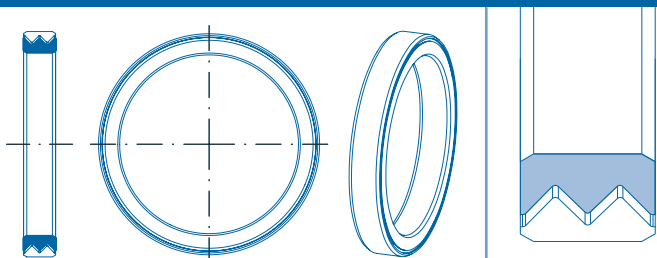

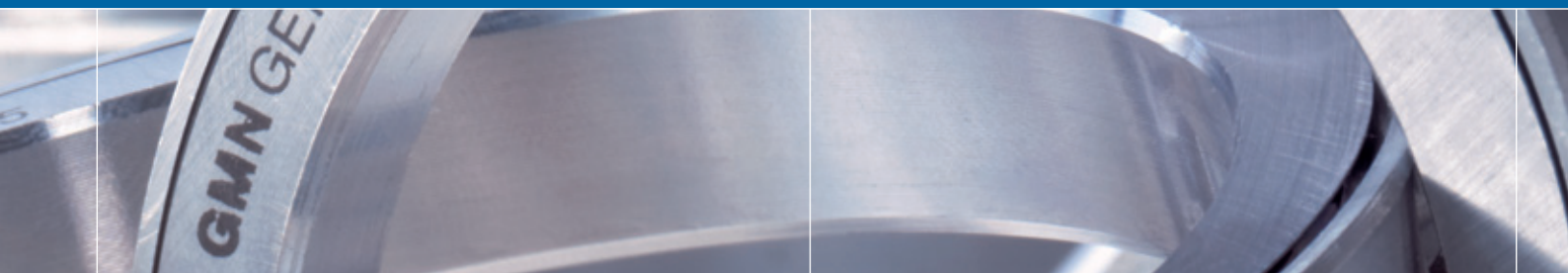

Technical data

Material

Outer ring: Aluminium (GD AISi 12)

Inner ring: Non-alloy steel

Range of temperature: -40°–200°C (-40°–392°F)

Design

Shaft diameter: 15–210 mm
(Customized solutions until max. 270 mm)

Width: 4*, 10, 14, 15, 20, 22 mm (depending on size)
(*Thin product line - DL)

Gap height: Constantly 0.2–0.5 mm
(Depending on size)

Sealing gap: Horizontal

Axial clearance: S_{ax} (see table of dimensions) = total axial movement of the seals inner and outer ring in relation to each other; from one end position to the other.

Increased axial clearance: On request all types are also available with increased axial clearance: $S'_{ax} = 1.5 \times S_{ax}$ (order example: L x D x B with increased axial clearance)

Radial clearance: $S_{rad} = S_{ax} / \tan(42.5^\circ)$

Type M

Heavy and direct splashing liquids could be drained through a certain number of grooves in the outer ring into a circular groove inside the housing;

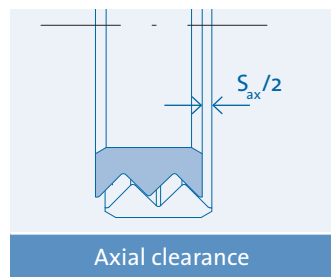

Axial clearance



Type M

The interlocked labyrinth design keeps inner- and outer ring together as an inseparable unit.

Characteristics

Material

- Robust

Metallic materials of GMN seal components guarantee highest resistance against coarse and fine contamination.

- Well suited for high temperature applications

Metallic materials are suitable for temperatures up to 200°C (392°F).

Design

- No friction

GMN-Seals guarantee operation without any frictional contact.

- No wear

GMN-Seals operate without any kind of wear, unlimited life possibilities.

- No abrasion

The Non-Contact design of GMN-L-Seals guarantees operation without any metallic abrasion. The L-Seal is suitable for the highest demands of cleanliness.

- Effective

The small distance between outer and inner ring of approx. 0.2-0.5 mm offers high sealing efficiency and effective protection against contamination.

- No increased temperatures

No friction means no thermal effects to the surrounding parts and/or the lubricant.

- Power saving performance

The specific design of the GMN Labyrinth Seal allows operating conditions without any power loss. The result is the highest efficiency and power saving performance in high speed applications.

- Compact design

GMN Labyrinth Seals are offering 1 to 4 labyrinth steps within a tight space.

- Efficiency

The small gap height creates an air cushion inside the gap at high rotating speeds which helps increase efficiency.

- Back transporting

Drain grooves on the outer ring are draining liquids with great effectiveness (Type M).

Labyrinth Metal Seals



ID	OD	W	c	e	S _{ax}	max. speed	Weight	Type L			Type M (with groove)		
								Type	Part no.	Part name	Type	Part no.	Part name
15	26	8	2.5	24	0.35	63,500	0.020	L	301171	L 15 x 26 x 8	M	301337	M 15 x 26 x 8
18	28	10	3	26	0.38	56,800	0.020	L	301176	L 18 x 28 x 10	M	301341	M 18 x 28 x 10
20	28	10	3	26	0.38	81,000	0.010	L	301178	L 20 x 28 x 10	M	301343	M 20 x 28 x 10
	30	10	3	28	0.38	70,700	0.010	L	301180	L 20 x 30 x 10	M	301345	M 20 x 30 x 10
22	30	10	3	28	0.38	71,400	0.010	L	301182	L 22 x 30 x 10	M	301347	M 22 x 30 x 10
25	37	10	3	34	0.38	50,600	0.030	L	301185	L 25 x 37 x 10	M	301349	M 25 x 37 x 10
28	39	10	3	36	0.38	45,700	0.030	L	301187	L 28 x 39 x 10	M	301351	M 28 x 39 x 10
30	42	10	3	39	0.38	48,900	0.030	L	301189	L 30 x 42 x 10	M	301353	M 30 x 42 x 10
32	45	10	3	42	0.40	43,300	0.040	L	301192	L 32 x 45 x 10	M	301355	M 32 x 45 x 10
35	47	10	3	44	0.40	39,800	0.040	L	301194	L 35 x 47 x 10	M	301357	M 35 x 47 x 10
40	52	10	3	49	0.40	33,300	0.040	L	301199	L 40 x 52 x 10	M	301360	M 40 x 52 x 10
42	55	10	3	52	0.40	30,100	0.050	L	301204	L 42 x 55 x 10	M	301364	M 42 x 55 x 10
45	55	10	3	52	0.40	30,700	0.030	L	301206	L 45 x 55 x 10	M	301366	M 45 x 55 x 10
	62	10	3	59	0.40	24,800	0.080	L	301210	L 45 x 62 x 10	M	301369	M 45 x 62 x 10
48	62	10	3	59	0.40	24,500	0.060	L	301215	L 48 x 62 x 10	M	301371	M 48 x 62 x 10
50	62	10	3	59	0.40	28,300	0.050	L	301217	L 50 x 62 x 10	M	301373	M 50 x 62 x 10
52	68	10	3	65	0.40	24,200	0.090	L	301220	L 52 x 68 x 10	M	301376	M 52 x 68 x 10
55	68	10	3	65	0.40	24,100	0.070	L	301222	L 55 x 68 x 10	M	301378	M 55 x 68 x 10
58	72	10	3	68.5	0.40	22,100	0.070	L	301226	L 58 x 72 x 10	M	301384	M 58 x 72 x 10
60	72	10	3	68.5	0.40	22,300	0.060	L	301228	L 60 x 72 x 10	M	301387	M 60 x 72 x 10
	80	10	3	76	0.40	18,900	0.130	L	301230	L 60 x 80 x 10	M	301389	M 60 x 80 x 10
63	80	10	3	76	0.40	18,700	0.100	L	301234	L 63 x 80 x 10	M	301392	M 63 x 80 x 10



ID	OD	W	c	e	S _{ax}	max. speed	Weight	Type L			Type M (with groove)		
								Type	Part no.	Part name	Type	Part no.	Part name
65	80	10	3	76	0.40	18,600	0.090	L	301237	L 65 x 80 x 10	M	301394	M 65 x 80 x 10
	85	10	3	81	0.42	17,000	0.140	L	301240	L 65 x 85 x 10	M	301396	M 65 x 85 x 10
68	85	10	3	81	0.42	16,800	0.110	L	301243	L 68 x 85 x 10	M	301400	M 68 x 85 x 10
70	85	10	3	81	0.42	16,700	0.140	L	301247	L 70 x 85 x 10	M	301404	M 70 x 85 x 10
	90	10	3	86	0.42	15,300	0.150	L	301250	L 70 x 90 x 10	M	301406	M 70 x 90 x 10
72	90	10	3	86	0.42	15,200	0.130	L	301254	L 72 x 90 x 10	M	301409	M 72 x 90 x 10
75	90	10	3	86	0.42	15,100	0.100	L	301257	L 75 x 90 x 10	M	301411	M 75 x 90 x 10
80	100	10	3	95	0.42	14,500	0.160	L	301266	L 80 x 100 x 10	M	301420	M 80 x 100 x 10
85	100	10	3	95	0.42	14,500	0.110	L	301270	L 85 x 100 x 10	M	301426	M 85 x 100 x 10
90	110	10	3	105	0.42	12,300	0.180	L	301272	L 90 x 110 x 10	M	301428	M 90 x 110 x 10
100	120	10	3	115	0.42	10,600	0.190	L	301278	L 100 x 120 x 10	M	301433	M 100 x 120 x 10
	120	14	4	115	0.70	11,100	0.250	L	301282	L 100 x 120 x 14	M	301437	M 100 x 120 x 14
110	130	15	5	125	0.70	11,700	0.290	L	301285	L 110 x 130 x 15	M	301439	M 110 x 130 x 15
120	140	15	5	135	0.70	10,400	0.310	L	301293	L 120 x 140 x 15	M	301445	M 120 x 140 x 15
130	150	15	5	145	0.70	9,200	0.330	L	301297	L 130 x 150 x 15	M	301449	M 130 x 150 x 15
140	170	15	5	165	0.70	7,500	0.650	L	301301	L 140 x 170 x 15	M	301453	M 140 x 170 x 15
150	180	15	5	175	0.70	6,800	0.700	L	301304	L 150 x 180 x 15	M	301455	M 150 x 180 x 15
160	190	20	5	184.5	0.80	6,200	0.950	L	301306	L 160 x 190 x 20	M	301457	M 160 x 190 x 20
170	210	20	5	204.5	0.80	5,400	1.500	L	301309	L 170 x 210 x 20	M	301460	M 170 x 210 x 20
180	210	20	5	204.5	0.80	5,300	1.070	L	301312	L 180 x 210 x 20	M	301463	M 180 x 210 x 20
190	230	20	5	224.5	0.80	4,700	1.660	L	301316	L 190 x 230 x 20	M	301468	M 190 x 230 x 20
200	230	20	5	224.5	0.80	4,600	1.180	L	301318	L 200 x 230 x 20	M	301470	M 200 x 230 x 20
210	250	22	5	244.5	1.00	4,000	1.960	L	301321	L 210 x 250 x 22	M	301473	M 210 x 250 x 22

ID = Inner diameter [mm]

OD = Outer diameter [mm]

W = Width

e = Gap diameter [mm]

c = Groove width

Max. speed [rpm]

S_{ax} = Axial clearance [mm]

Weight [kg]

GMN Labyrinth Metal Seals Specials

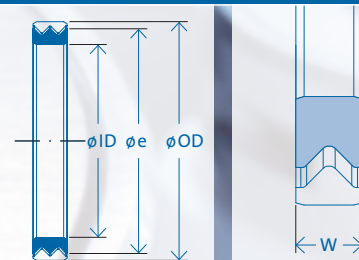

In addition to our standard products, GMN offers many special solutions.

Reduced width

Series DL is engineered specifically for limited space designs. For shaft diameters up to 65mm, the seal width is only 4mm. This small seal could protect existing Contact Seals against chips and abrasive particles reliably and the lifetime of the complete sealing system increases greatly.

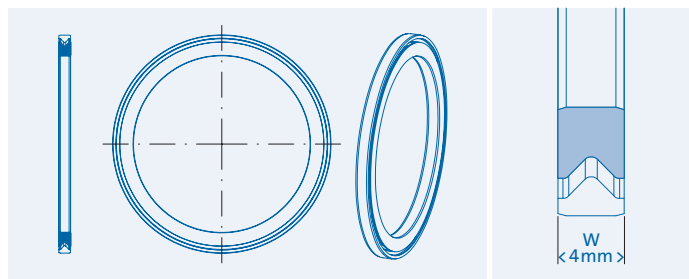

Different material

In applications against aggressive and corrosive media, GMN produces Labyrinth Seals Type L and M made from alternative material:

- Inner ring made of stainless steel
- Outer ring made of aluminium or zinc

Special sizes

On request, GMN can also produce customized dimensions.



GMN Non-Contact Seals with reduced width							Type DL		
ID	OD	W	e	S _{ax}	max. speed	Weight	Type	Part no.	Part name
15	26	4	24	0.35	53,000	0.010	DL	306347	DL 15 x 26 x 4
20	28	4	26	0.38	60,000	0.010	DL	306354	DL 20 x 28 x 4
25	37	4	34	0.38	41,000	0.020	DL	306364	DL 25 x 37 x 4
30	42	4	39	0.38	39,000	0.020	DL	306188	DL 30 x 42 x 4
35	47	4	44	0.40	32,000	0.025	DL	306190	DL 35 x 47 x 4
40	52	4	49	0.40	27,000	0.030	DL	306365	DL 40 x 52 x 4
45	62	4	59	0.40	22,000	0.045	DL	306366	DL 45 x 62 x 4
50	62	4	59	0.40	20,000	0.030	DL	306367	DL 50 x 62 x 4
55	68	4	65	0.40	20,500	0.040	DL	306368	DL 55 x 68 x 4
60	72	4	68.5	0.40	18,500	0.040	DL	306192	DL 60 x 72 x 4
63	80	4	76	0.40	14,000	0.060	DL	306186	DL 63 x 80 x 4
65	80	4	76	0.40	14,000	0.055	DL	306194	DL 65 x 80 x 4
110	130	10	125	0.70	9,900	0.300	DL	306196	DL 110 x 130 x 10
120	140	10	135	0.70	8,800	0.320	DL	306198	DL 120 x 140 x 10

ID = Inner diameter [mm]
OD = Outer diameter [mm]

W = Width
e = Gap diameter [mm]

c = Groove width
Max. speed [rpm]

S_{ax} = Axial clearance [mm]
Weight [kg]

Mounting tolerances (mating parts)

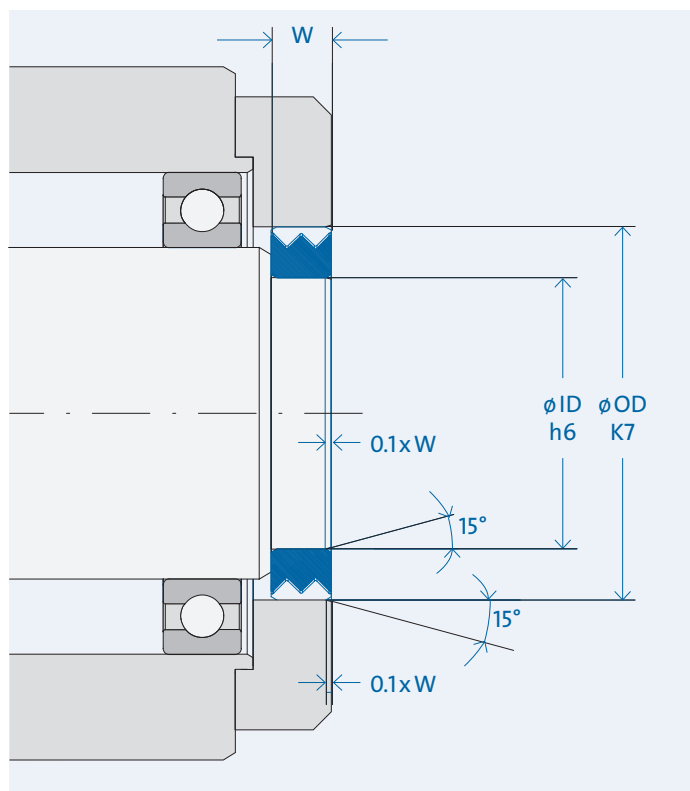

Tolerances

Surrounding constructions (mating component)

Fits

Housing: K7

Shaft: h6

Surface: $Rz \leq 16 \mu\text{m}$; $Ra \leq 3.2 \mu\text{m}$

Assembly

"l" Length (chamfer of housing and shaft) depending on the width "W": $l = 0.1 \times W$

Aluminium outer ring

The softer aluminium outer ring may be deformed during transport and arrive out of roundness. When the seal is then pressed into the housing, the outer ring easily re-forms to the circular housing.

The outer ring could also be wider by max. 0.1mm than the inner ring.

GMN Metal Seals are pressed through a round steel ring to calibrate the outer ring. After this process the outer ring widens again a little bit due to its elasticity.

Outer ring after calibrating

Plus-tolerance OR (mm)

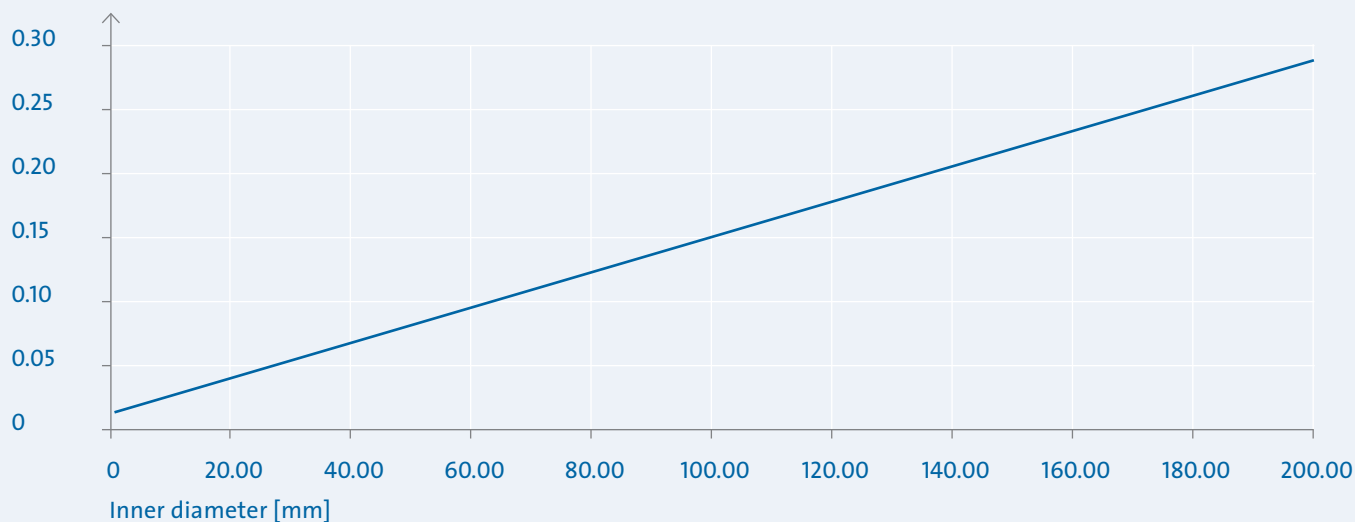

GMN Labyrinth Plastic Seals Type S and SA

Type S

Against normal splashing liquids
For rotating shafts and housings



Type SA with drain groove

Against heavy splashing liquids
For rotating shafts only (increased back transport)

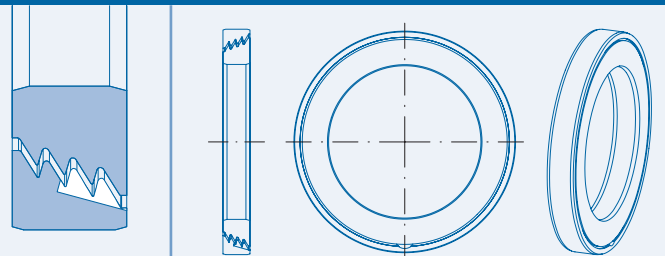
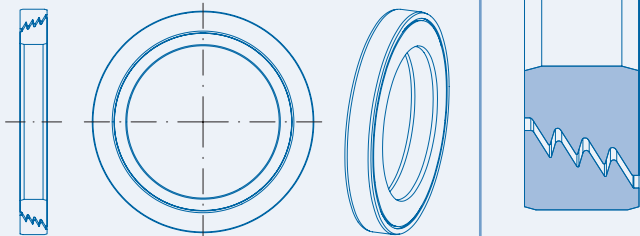



Technical Data

Material

Outer- and inner ring: high quality Polyoxymethylene plastic (POM)

Temperature range: -40°–60°C (-40°–140°F)
special design with O-ring up to 80°C (170°F)

Design

Shaft diameter: 10–160 mm
(customized solutions available upon request)

Width: 6.5*, 10, 12, 15 mm (depending on size)
(*thin product line - DS)

Sealing gap: Conical

Axial clearance: $S_{ax} = 1\text{mm}$
Total axial movement of the seals inner and outer ring in relation to each other from one end position to the other.

Type SA Heavy and direct splashing liquids could be drained through an additional groove in the outer ring – for rotating shafts only.

Greased seals: Pre-greased Seals Type S – available in all sizes – provide improved protection against dust.

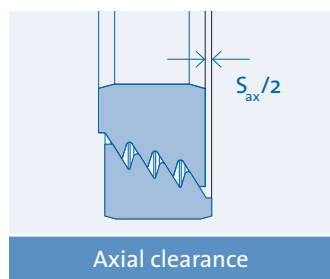

Axial clearance

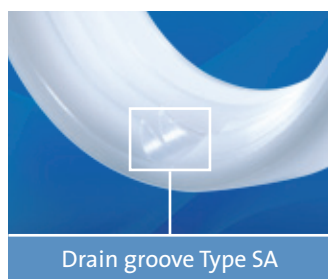

Drain groove Type SA

The labyrinth peaks are overlapping each other. With the assembly the rings are simply clicked together.

Characteristics

Material

- Non corrosive

GMN Plastic Seals are made from non corrosive material and are particularly suitable against watery liquids.

- Chemical resistant

Polyoxymethylene (POM) guarantees high resistance against a lot of acids (i.e. lactic acid), chemicals and fungi. *GMN Non-Contact Plastic Seals are approved for the food Industry.*

Design

- No friction

GMN-Seals operate without any frictional contact.

- No wear

GMN-Seals operate without any kind of wear, unlimited life possibilities.

- No abrasion

The Non-Contact design of GMN Labyrinth Seals guarantee operation without any abrasion. *(GMN Plastic Non-Contact Seals are suitable for the highest demands of cleanliness.)*

- Effective

The small distance between outer and inner ring offers high sealing efficiency and effective protection against contamination.

- No increased temperatures

No friction means no thermal effects to the surrounding parts and/or the lubricant.

- Power saving performance

The specific design of the GMN Labyrinth Seal allows operating conditions without any power loss. The result is the highest efficiency and power saving performance in high speed applications.

- Compact design

GMN Labyrinth Plastic Seals are offering 2 to 4 labyrinth steps within a small space.

- Efficient

GMN Labyrinth Seal Type S and SA take advantage of the centrifugal force to improve the sealing efficiency. Entering liquids are transported back to the bigger gap diameter with the rotation of the inner ring. Because of this effect, the bigger gap diameter (e_2) of the Labyrinth seal must always face the splashing liquids/contamination.

- Back transporting

Special seal Type SI is specifically designed for rotating housings. Passing liquids are drained with an additional groove at the inner ring.

- Dust-free

The gap of pre-greased seals is filled with a specific grease type and improves protection against dust and fine particles.

Labyrinth Plastic Seals



ID	OD	W	e1	e2	S _{ax}	max. speed	Weight	Type S			Type SA (with groove)		
								Type	Part no.	Part name	Type	Part no.	Part name
10	30	10	14	24	1	82,000	0.010	S	301491	S 10 X 30 X 10	SA	301753	SA 10 X 30 X 10
12	32	10	14	24	1	75,000	0.010	S	301494	S 12 X 32 X 10	SA	301756	SA 12 X 32 X 10
	37	10	19	24	1	59,500	0.010	S	301496	S 12 X 37 X 10	SA	301758	SA 12 X 37 X 10
15	35	10	19	29	1	53,400	0.010	S	301498	S 15 X 35 X 10	SA	301759	SA 15 X 35 X 10
	42	10	24	34	1	44,300	0.010	S	301501	S 15 X 42 X 10	SA	301762	SA 15 X 42 X 10
17	35	10	19	29	1	67,900	0.010	S	301506	S 17 X 35 X 10	SA	301767	SA 17 X 35 X 10
	40	10	24	34	1	56,900	0.010	S	301509	S 17 X 40 X 10	SA	301771	SA 17 X 40 X 10
	47	10	31	41	1	45,600	0.020	S	301511	S 17 X 47 X 10	SA	301773	SA 17 X 47 X 10
20	40	10	24	34	1	51,300	0.010	S	301515	S 20 X 40 X 10	SA	301777	SA 20 X 40 X 10
	42	10	24	34	1	51,300	0.010	S	301516	S 20 X 42 X 10	SA	301779	SA 20 X 42 X 10
	47	10	31	41	1	45,600	0.020	S	301517	S 20 X 47 X 10	SA	301781	SA 20 X 47 X 10
22	42	10	24	34	1	48,500	0.010	S	301520	S 22 X 42 X 10	SA	301786	SA 22 X 42 X 10
25	47	10	31	41	1	40,500	0.010	S	301523	S 25 X 47 X 10	SA	301789	SA 25 X 47 X 10
	52	10	31	41	1	40,500	0.020	S	301524	S 25 X 52 X 10	SA	301791	SA 25 X 52 X 10
28	47	10	31	41	1	37,800	0.010	S	301533	S 28 X 47 X 10	SA	301802	SA 28 X 47 X 10
	52	10	31	41	1	37,800	0.020	S	301534	S 28 X 52 X 10	SA	301803	SA 28 X 52 X 10
30	62	10	46	56	1	25,900	0.030	S	301537	S 30 X 62 X 10	SA	301807	SA 30 X 62 X 10
	72	10	47	61	1	24,500	0.040	S	301541	S 30 X 72 X 10	SA	301812	SA 30 X 72 X 10
35	62	10	46	56	1	23,900	0.020	S	301547	S 35 X 62 X 10	SA	301819	SA 35 X 62 X 10
	72	10	47	61	1	22,600	0.030	S	301550	S 35 X 72 X 10	SA	301824	SA 35 X 72 X 10
36	62	10	46	56	1	23,500	0.020	S	301555	S 36 X 62 X 10	SA	301829	SA 36 X 62 X 10
40	62	10	46	56	1	22,000	0.020	S	301567	S 40 X 62 X 10	SA	301842	SA 40 X 62 X 10
	68	10	47	62	1	21,000	0.030	S	301570	S 40 X 68 X 10	SA	301845	SA 40 X 68 X 10
	90	10	60	74	1	17,300	0.060	S	301576	S 40 X 90 X 10	SA	301851	SA 40 X 90 X 10
42	65	10	46	56	1	25,300	0.020	S	301578	S 42 X 65 X 10	SA	301854	SA 42 X 65 X 10
	72	10	47	61	1	24,100	0.030	S	301580	S 42 X 72 X 10	SA	301857	SA 42 X 72 X 10
45	80	10	60	74	1	19,200	0.040	S	301584	S 45 X 80 X 10	SA	301862	SA 45 X 80 X 10
	85	10	60	74	1	19,200	0.050	S	301585	S 45 X 85 X 10	SA	301864	SA 45 X 85 X 10

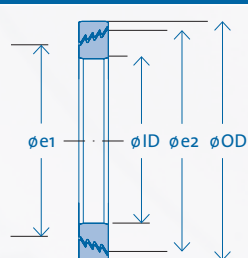

Type S

Type SA (with groove)

ID	OD	W	e1	e2	S _{ax}	max. speed	Weight	Type S			Type SA (with groove)		
								Type	Part no.	Part name	Type	Part no.	Part name
50	80	10	60	74	1	17,800	0.030	S	301593	S 50 X 80 X 10	SA	301873	SA 50 X 80 X 10
	90	10	60	74	1	17,800	0.050	S	301596	S 50 X 90 X 10	SA	301876	SA 50 X 90 X 10
55	80	10	60	74	1	19,100	0.030	S	301606	S 55 X 80 X 10	SA	301886	SA 55 X 80 X 10
	85	10	60	74	1	19,100	0.040	S	301608	S 55 X 85 X 10	SA	301888	SA 55 X 85 X 10
60	95	12	72	87	1	15,400	0.060	S	301618	S 60 X 95 X 12	SA	301899	SA 60 X 95 X 12
	110	12	87	102	1	13,200	0.090	S	301622	S 60 X 110 X 12	SA	301901	SA 60 X 110 X 12
65	100	12	72	87	1	16,300	0.060	S	301631	S 65 X 100 X 12	SA	301910	SA 65 X 100 X 12
68	95	12	72	87	1	15,800	0.050	S	301639	S 68 X 95 X 12	SA	301918	SA 68 X 95 X 12
70	110	12	87	102	1	13,400	0.080	S	301643	S 70 X 110 X 12	SA	301920	SA 70 X 110 X 12
	125	15	96	112	1	12,300	0.170	S	301646	S 70 X 125 X 15	SA	301923	SA 70 X 125 X 15
75	130	15	96	112	1	12,900	0.160	S	301659	S 75 X 130 X 15	SA	301936	SA 75 X 130 X 15
80	110	12	87	102	1	13,300	0.060	S	301666	S 80 X 110 X 12	SA	301944	SA 80 X 110 X 12
	140	15	116	132	1	9,600	0.180	S	301671	S 80 X 140 X 15	SA	301950	SA 80 X 140 X 15
82	110	12	87	102	1	13,100	0.060	S	301675	S 82 X 110 X 12	SA	301954	SA 82 X 110 X 12
85	120	15	96	112	1	10,800	0.100	S	301678	S 85 X 120 X 15	SA	301956	SA 85 X 120 X 15
90	120	15	96	112	1	10,400	0.090	S	301687	S 90 X 120 X 15	SA	301963	SA 90 X 120 X 15
	145	15	116	132	1	9,800	0.200	S	301691	S 90 X 145 X 15	SA	301968	SA 90 X 145 X 15
95	140	15	116	132	1	9,500	0.150	S	301697	S 95 X 140 X 15	SA	301973	SA 95 X 140 X 15
100	140	15	116	132	1	9,100	0.130	S	301704	S 100 X 140 X 15	SA	301981	SA 100 X 140 X 15
110	140	15	116	132	1	7,900	0.100	S	301715	S 110 X 140 X 15	SA	301992	SA 110 X 140 X 15
120	150	15	126	142	1	6,200	0.110	S	301725	S 120 X 150 X 15	SA	302002	SA 120 X 150 X 15
125	170	15	146	162	1	5,400	0.210	S	301729	S 125 X 170 X 15	SA	302008	SA 125 X 170 X 15
130	170	15	146	162	1	5,200	0.190	S	301731	S 130 X 170 X 15	SA	302011	SA 130 X 170 X 15
140	170	15	146	162	1	5,000	0.140	S	301739	S 140 X 170 X 15	SA	302019	SA 140 X 170 X 15
150	190	15	166	182	1	4,300	0.190	S	301746	S 150 X 190 X 15	SA	302025	SA 150 X 190 X 15
160	190	15	166	182	1	4,100	0.140	S	301750	S 160 X 190 X 15	SA	302029	SA 160 X 190 X 15

ID = Inner diameter [mm]
OD = Outer diameter [mm]

W = Width
e2 = Gap diameter [mm]

e1 = Groove width
Max. speed [rpm]

S_{ax} = Axial clearance [mm]
Weight [kg]

GMN Labyrinth Plastic Seals Specials

Besides our wide range of standard products GMN offers many special solutions.

Special sizes

Upon request, GMN can also produce customized dimensions.

Thin Type DS

For applications with limited seal space, GMN offers thin plastic seals with width 6.5 mm; these seals are available upon request.

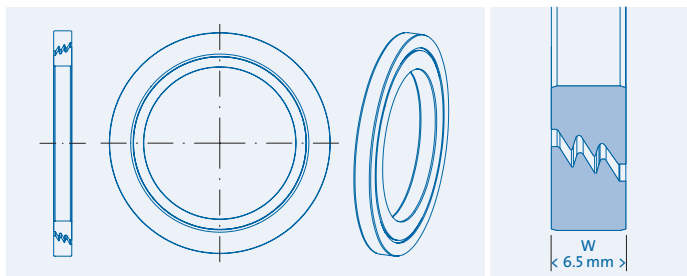

Specials with O-ring-design and Type SI are available in all GMN standard sizes



Special design with O-ring for higher temperatures up to 176°F [80°C]

In applications with high temperatures, an additional O-ring at the outer ring (also available at the inner ring) saves the press fit and keeps the seal in position.



Type SI with drain groove at the inner ring

In applications with a rotating housing, GMN offers a drain groove (similar to Type SA) at the inner ring.

Quotes upon request.

Mounting tolerances

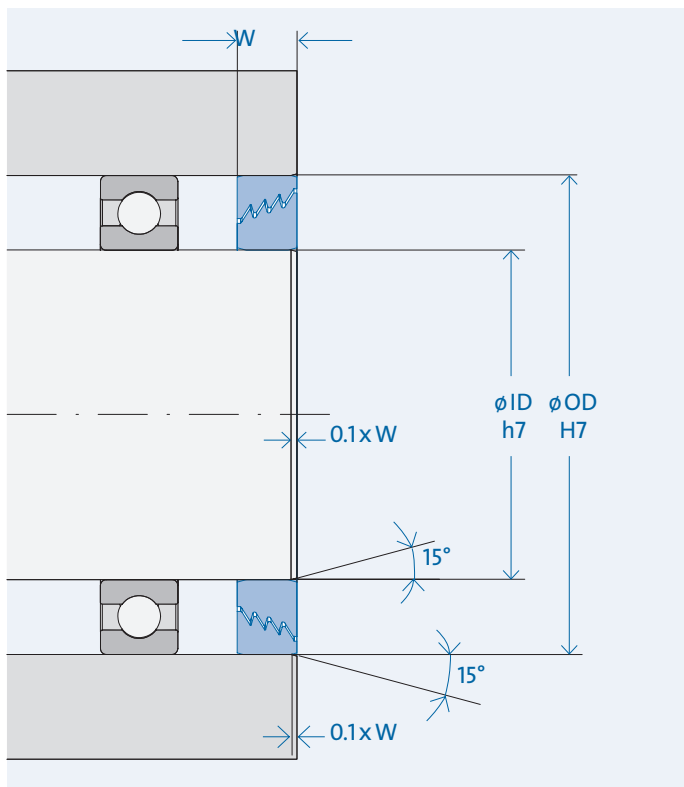

Tolerances

Surrounding constructions (mating component)

Fits

Housing: H7

Shaft: h7

Surface: $Rz \leq 16 \mu\text{m}$; $Ra \leq 3.2 \mu\text{m}$

Assembly

"l" Length (chamfer of housing and shaft) depending on the width

"W": $l = 0.1 \times W$

Installation

General information

When installing a GMN Non-Contact Seal, one must be certain that both the inner and outer races are axially aligned. Furthermore, the races need to be unrestricted by any shoulder, nut(s), and/or other restrictions from axial movement.

Surrounding construction

An additional disc in front of the seal protects the gap against strong and direct splashing liquids. The disc should be assembled in front of the seal with sufficient distance (capillary forces should be considered).

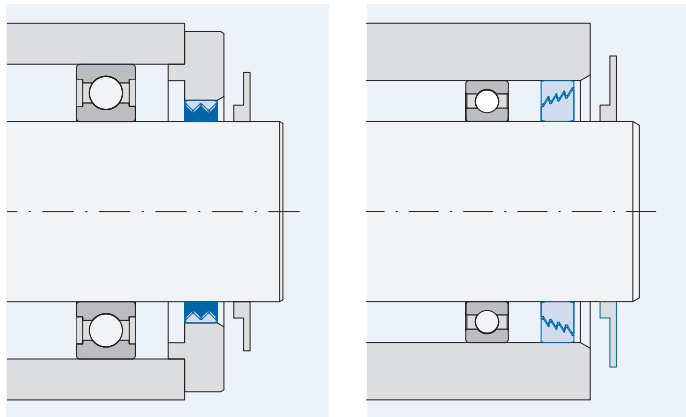

Non-Contact Seal (metal):
Type L
with disc

Non-Contact Seal (plastic):
Type S
with disc

Any kind of high liquid level in front of the seal's gap needs to be avoided. (Attention: High liquid levels may cause leakage).

In a non-horizontal working application, GMN can offer specific advice to optimize your individual design in order to protect the sealing gap effectively.

When using Type SA and SI, care should be taken that the drain groove in the stationary part is always positioned at the lowest point.

Standard assembly

Non-Contact Seal (metal)
Type L

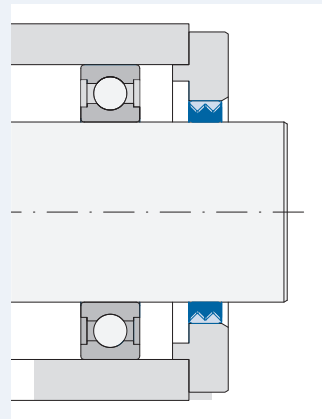

Non-Contact Seal (plastic)
Type S

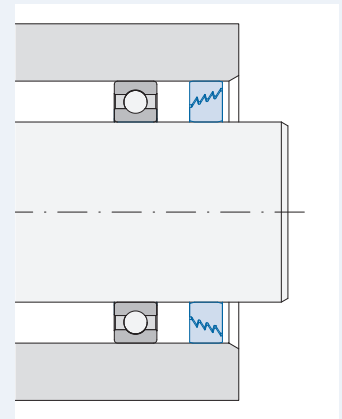

Shaft shoulder

A precise positioning of the seal is provided with a shaft shoulder for the inner ring.

The outer ring of GMN Labyrinth Metal Seals made of metal should be positioned freely without any shoulder.

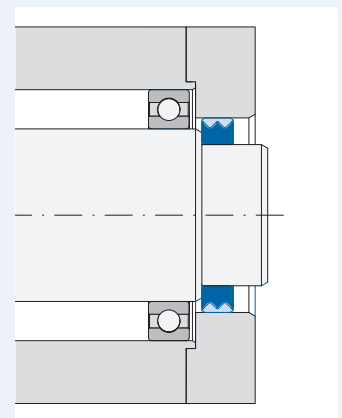

Orientation of Plastic Seals

The bigger gap diameter (e2) of the GMN Labyrinth Plastic Seals must always face the splashing liquids/contamination.

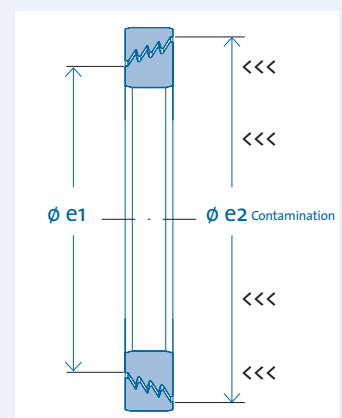



Face-mounting with pre-assembled bearing

Both rings of the seal are pressed-in with an assembling aid (i.e. tube) together at the same time. If pressure would be applied on one ring only the labyrinth could be destroyed.

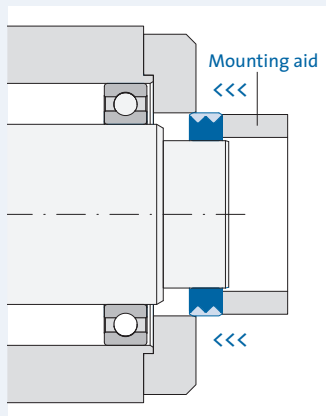

(The outer ring could be wider by maximum 0.1 mm than the inner ring.)

Assembly inside the unit

1. The GMN seal is pre-assembled onto the shaft. A thin metal sheet mounting aid (Thickness $S_{ax}/2$, half the amount of the seal's axial clearance) should be inserted between the housing and an additional ring.

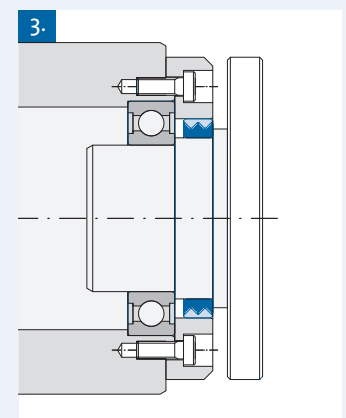
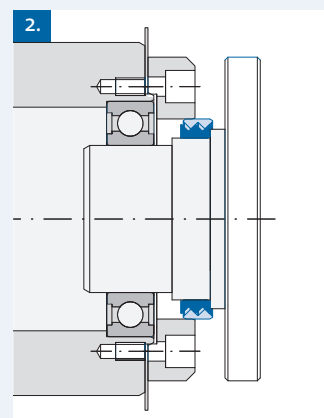
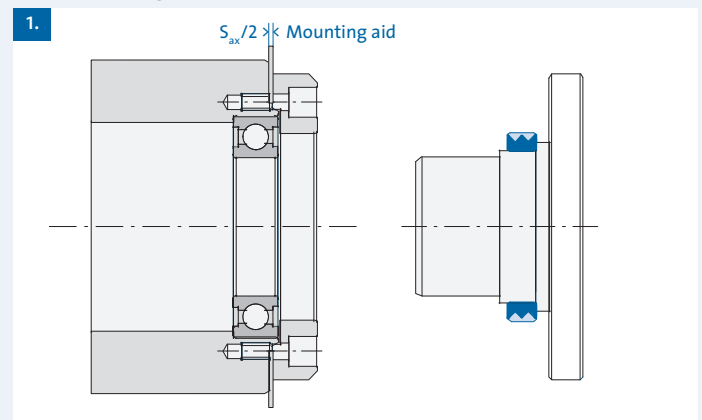

2. Shaft (with the seal) and housing (with the bearing) are fitted into each other carefully. Now the outer ring stands in the right-hand end position of the seal.

3. Finally the mounting aid is removed and the screws are tightened. With this process the seal's outer ring moves to the left by $S_{ax}/2$ and finds itself in the final, correct non-contact position.

Installation

Specific Assembly Situations

Assembly with pre-loaded spindle bearings

The seal's outer and inner ring cannot be affected when the bearing is pre-loaded.

The assembly into the cover keeps the seal independent from any bearing displacement.

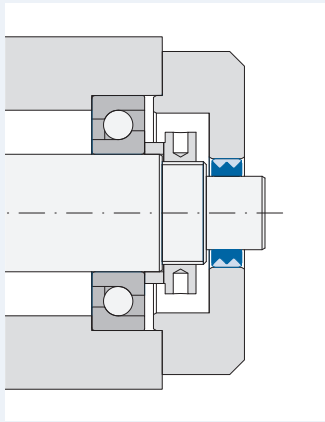

Shaft Expansion with Temperature

To avoid any increase of the maximum axial clearance, GMN recommends a seal with an increased axial clearance or an asymmetrical seal adjustment in the extension direction. (The excess of maximum axial clearance could destroy the seal.)

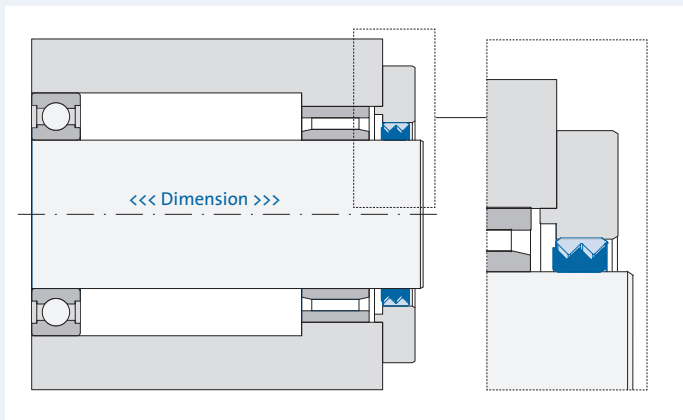

Seals with drainage

Tandem arrangement

Metal Seal (Type L)

100% sealing efficiency is guaranteed with two seals in a row (minimum distance 5 mm) with a drain hole in between. With this design any liquid between the seals could be drained reliably.

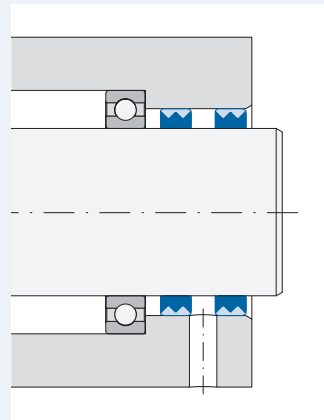

Plastic Seal (Type S)

The tandem arrangement of the plastic seals require opposite orientation with the assembly. One seal is operating specifically against possible contamination from outside while the other seal keeps the bearing's lubrication inside.

The bigger gap-diameter always faces the contamination.

(Space between the seals: min. 5 mm)

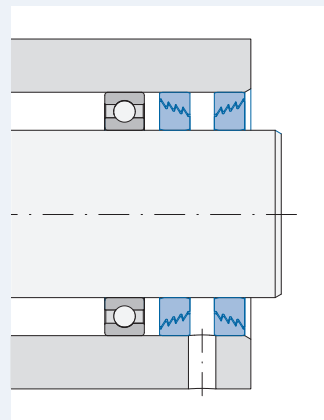

Seals with drain groove

Metal Seal (Type M)

In case of limited construction space Type M offers a compromise of the tandem arrangement in a tight package.

Passing liquid is centrifugally forced through the outer ring's grooves into a drain groove inside the housing. *Width of the drain groove in housing: $R = c + 1\text{mm}$ (c = drain groove width)*

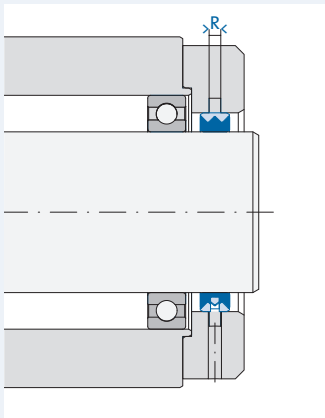

Plastic Seal (Type SA and SI)

When using the Type SA or SI, care should be taken that the drain groove in the stationary part is always positioned at the lowest point.

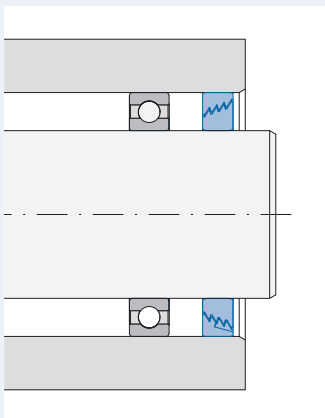

Sealing air

Sealing air improves the efficiency of the seal, but please note the reasonable amount of air consumption. If sealing air should be applied through the grooves of the M Type the air releases in both directions of the seal; paying special attention with the bearing.

Additional aspects to consider

Correct choice of the seal as well as customized design of the mating parts is the most important aspects for a successful application, but there is more. If a milling machine is stopped suddenly within a very short time, a temporary oil level could be created in front of the sealing gap. The following questions should help to analyze your application from different points of view:

Is the level of the sealing gap fixed?

Would another size of the seal move the sealing gap into a more protected area?

Could the viscosity of the cooling/oil etc. be influenced in a positive way?

Are there any existing components (i.e. shield) which could be included into a complete design?

Are all drain holes and drain grooves big enough?

Could any possibility of backwater be excluded?

What is the size of any particles to be sealed? What is their speed and direction?

Could any negative aspects be changed in a positive way with the control system?

...

On request, GMN would be pleased to give advice based on our decades of experience in order to optimize your individual solution.

Product overview

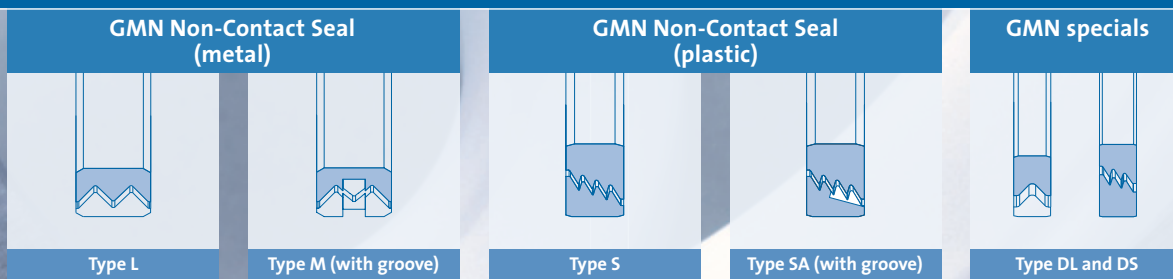

Bearing size*

ID	GMN Non-Contact Seal (metal)				GMN Non-Contact Seal (plastic)				GMN specials				DIN								
	L	ID	OD	W	M	ID	OD	W	S	ID	OD	W		SA	ID	OD	W	D	ID	OD	W
8																	DS	8	22	6,5	608
10									S	10	30	10	SA	10	30	10					6200
12									S	12	32	10	SA	12	32	10					6201
15	L	15	26	8	M	15	26	8	S	12	37	10	SA	12	37	10	DL	15	26	4	6301
17									S	15	35	10	SA	15	35	10					6202
18	L	18	28	10	M	18	28	10	S	15	42	10	SA	15	42	10					6302
20	L	20	28	10	M	20	28	10	S	17	35	10	SA	17	35	10	DL	20	28	4	6003
22	L	22	30	10	M	22	30	10	S	17	40	10	SA	17	40	10	DS	20	47	6,5	6204
25	L	25	37	10	M	25	37	10	S	17	47	10	SA	17	47	10					61805
28	L	28	39	10	M	28	39	10	S	25	52	10	SA	25	52	10	DL	25	37	4	6005
30	L	30	42	10	M	30	42	10	S	25	52	10	SA	25	52	10					6205
32	L	32	45	10	M	32	45	10	S	28	47	10	SA	28	47	10					61806
35	L	35	47	10	M	35	47	10	S	28	52	10	SA	28	52	10	DL	30	42	4	6206
36									S	30	62	10	SA	30	62	10					6306
40	L	40	52	10	M	40	52	10	S	30	72	10	SA	30	72	10	DL	35	47	4	61807
42	L	42	55	10	M	42	55	10	S	35	62	10	SA	35	62	10					6007
45	L	45	55	10	M	45	55	10	S	35	72	10	SA	35	72	10	DL	40	52	4	6207
48	L	48	62	10	M	48	62	10	S	40	62	10	SA	40	62	10					61808
50	L	50	62	10	M	50	62	10	S	40	68	10	SA	40	68	10	DL	45	62	4	6008
									S	40	90	10	SA	40	90	10					6308
									S	42	65	10	SA	42	65	10					61808
									S	42	72	10	SA	42	72	10					61908
									S	45	80	10	SA	45	80	10	DL	50	62	4	6008
									S	45	85	10	SA	45	85	10					6308
									S	50	80	10	SA	50	80	10	DL	45	62	4	6209
									S	50	90	10	SA	50	90	10					6209
									S	50	90	10	SA	50	90	10	DL	50	62	4	6010

Special Sizes on request ($d_{max}=270mm$)

ID = Inner diameter [mm]

OD = Outer diameter [mm]

W = Width [mm]

*ID and OD according to bearing sizes

Width W off-size

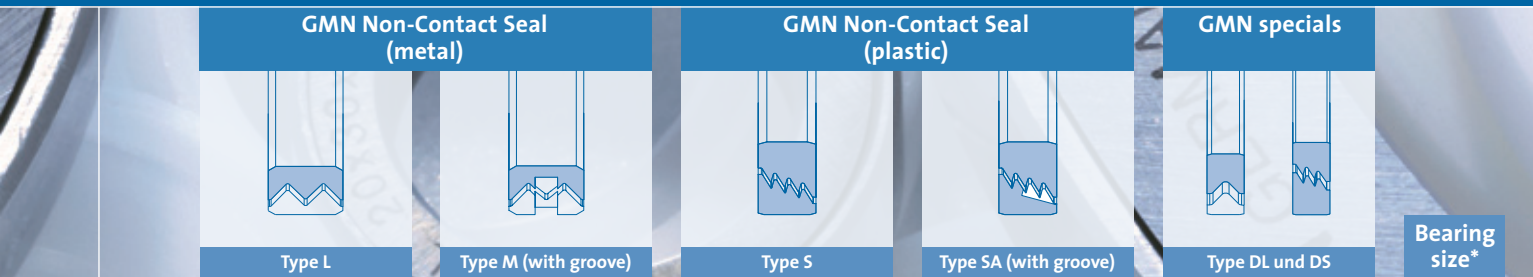

ID	GMN Non-Contact Seal (metal)				GMN Non-Contact Seal (plastic)				GMN specials				Bearing size*	DIN								
	L	ID	OD	W	M	ID	OD	W	S	ID	OD	W			SA	ID	OD	W	D	ID	OD	W
52	L	52	68	10	M	52	68	10														
55	L	55	68	10	M	55	68	10	S	55	80	10	SA	55	80	10	DL	55	68	4	61911	
	L	55	85	10	M	55	90	10	S	55	85	10	SA	55	85	10						
58	L	58	72	10	M	58	72	10														
60	L	60	72	10	M	60	72	10	S	60	95	12	SA	60	95	12	DL	60	72	4	6012 6212	
	L	60	80	10	M	60	80	10														S
63	L	63	80	10	M	63	80	10									DL	63	80	4		
65	L	65	80	10	M	65	85	10	S	65	100	12	SA	65	100	12	DL	65	80	4	61813 6013	
	L	65	85	10	M	65	90	10														S
68	L	68	85	10	M	68	85	10	S	68	95	12	SA	68	95	12						
70	L	70	85	10	M	70	85	10	S	70	110	12	SA	70	110	12					61814 6014 6214	
	L	70	90	10	M	70	90	10														S
72	L	72	90	10	M	72	90	10														
75	L	75	90	10	M	75	90	10	S	75	130	15	SA	75	130	15					6215	
80	L	80	100	10	M	80	100	10	S	80	110	12	SA	80	110	12					61816 61916 6216	
82									S	82	110	12	SA	82	110	12						
85	L	85	100	10	M	85	100	10	S	85	120	15	SA	85	120	15					61917	
90	L	90	110	10	M	90	110	10	S	90	120	15	SA	90	120	15						
95									S	95	140	15	SA	95	140	15						
100	L	100	120	10	M	100	120	10	S	100	140	15	SA	100	140	15					61920	
	L	100	120	14	M	100	120	14														S
110	L	110	130	15	M	110	130	15	S	110	140	15	SA	110	140	15	DL	110	130	10	61822	
120	L	120	140	15	M	120	140	15	S	120	150	15	SA	120	150	15	DL	120	140	10	61824	
125									S	125	170	15	SA	125	170	15						
130	L	130	150	15	M	130	150	15	S	130	170	15	SA	130	170	15						
140	L	140	170	15	M	140	170	15	S	140	170	15	SA	140	170	15						
150	L	150	180	15	M	150	180	15	S	150	190	15	SA	150	190	15					61830	
160	L	160	190	20	M	160	190	20	S	160	190	15	SA	160	190	15						
170	L	170	210	20	M	170	210	20														
180	L	180	210	20	M	180	210	20														
190	L	190	230	20	M	190	230	20														
200	L	200	230	20	M	200	230	20														
210	L	210	250	22	M	210	250	22														

Tolerance table

Tolerances

Housing	Extract of DIN ISO 286-2						
Bore diameter (OD) Nominal size [mm]; above to	10 18	18 30	30 50	50 80	80 120	120 180	180 250
Tolerances [μm]							
K7	+6 -12	+6 -15	+7 -18	+9 -21	+10 -25	+12 -28	+13 -33
M7	0 -18	0 -21	0 -25	0 -30	0 -35	0 -40	0 -46
N7	-5 -23	-7 -28	-8 -33	-9 -39	-10 -45	-12 -52	-14 -60
H7	+18 0	+21 0	+25 0	+30 0	+35 0	+40 0	+46 0
G7	+24 +6	+28 +7	+34 +9	+40 +10	+47 +12	+54 +14	+61 +15

Shaft	Extract of DIN ISO 286-2						
Shaft diameter (d) Nominal size [mm]; above to	10 18	18 30	30 50	50 80	80 120	120 180	180 250
Tolerances [μm]							
h6	0 -11	0 -13	0 -16	0 -19	0 -22	0 -25	0 -29
j6	+8 -3	+9 -4	+11 -5	+12 -7	+13 -9	+14 -11	+16 -13
k6	+12 +1	+15 +2	+18 +2	+21 +2	+25 +3	+28 +3	+33 +4
g6	-6 -17	-7 -20	-9 -25	-10 -29	-12 -34	-14 -39	-15 -44
f6	-16 -34	-20 -41	-25 -50	-30 -60	-36 -71	-43 -83	-50 -96

Index

Abrasive contamination	10	Horizontal installation position	26	Rotating housing	14,20
Advantages, ecological	10	Installation (general)	26	Rotating shaft	14,20
Advantages, economical	10	Installation inside the unit	27	Rotation speed (selection sealing system)	12
Aluminium outer ring	19	Installation situations, specific	28	Rotation speed, high (application)	10
Applications	10,11	Labyrinth	9	Sealing air	29
Axial clearance, increased	15,28	Labyrinth design	9	Sealing effect	9
Axial clearance, Metal Seal	15	Labyrinth Plastic Seal, greased	21	Sealing efficiency	29
Axial clearance, Plastic Seal	21	Labyrinth Seal Type DS	24	Sealing gap, conical	9,21
Back transport (function)	8	Labyrinth Seal Type S	20,21	Sealing gap, horizontal	9,15
Back transport (product characteristics)	15,21	Labyrinth Seal Type SA	20,21	Sealing system characteristics (selection sealing system)	12
Basics	8	Life time (selection Sealing system)	12	Selection assistant of sealing system	12
Bearing sizes	30	Life time increased (application)	10	Shaft extension (installation)	28
Benefits	10	Life time limit (comparison)	7	Shaft extension with temperature (installation)	28
Calibration	19	Lifting-off speed	13	Shaft rotation (function)	8
Capillary force	26	Limits of use (seal)	13	Shaft shoulder (installation)	26
Centrifugal force	9	Linear extension (installation)	28	Shielding (function)	8
Characteristics, Labyrinth Metal Seal	15	Liquid level	13,29	Sizes (product range)	30,31
Characteristics, Labyrinth Plastic Seal	21	Liquid level (selection sealing system)	12	Special material	18
Characteristics, sealing system (selection sealing system)	12	Liquid splashing (selection sealing system)	12	Specials Metal Seals	18
Chemical Industry (application)	11	Lubrication of the seal (comparison)	7	Specials Plastic Seals	24
Chemicals (selection sealing system)	12	Machine standstill (function)	8	Speed limit	13
Chemicals, resistance against (product characteristics)	21	Machine tool industry (applications)	11	Speed limit (comparison)	7
Classification	6	Machining spindles (application)	11	Spindle bearing pre-assembled (installation)	28
Cleanliness high (application)	10,11	Maintenance (selection sealing system)	12	Spindle head (application)	11
Comparison to contact seal	7	Maintenance, low costs (application)	10	Stainless steel	18
Components around (function)	8	Mating parts	8,26	Standard installation	26
Conical gap	9,21	Mating parts, hardening and grinding (comparison)	7	Static seals	6
Contact Seal (comparison)	7	Mating parts, Metal Seal	19	Switching (function)	8
Contamination (comparison)	7	Mating parts, Plastic Seal	25	Tandem arrangement Metal Seal	28
Design of Metal Seal	14	Mating parts, requirements to (selection sealing system)	12	Tandem arrangement Plastic Seal	28
Design of Plastic Seal	20	Mounting tolerances Metal Seal	19	Technical advantages	10
Disc	26	Mounting tolerances Plastic Seal	25	Technical data, Metal Seal	15
Drain groove Metal Seal	14,15,29	Non-Contact Labyrinth Seal (comparison)	7	Technical data, Plastic Seal	21
Drain groove Plastic Seal	20,21,29	Non-corrosive (product characteristics)	21	Technical data, Metal material	15
Drain grooves	29	Oil shield	29	Technical data, Plastic material	21
Drain holes	26,29	Orientation of Plastic Seals (installation)	26,28	Temperature range (comparison)	7
Drainage (installation)	28	O-ring	24	Temperature range, Metal Seal	15
Draining (function)	8	Outer ring (alu)	19	Temperature range, Plastic Seal	21
Dust (selection sealing system)	12	Paper Industry (application)	10	Temperature, increasing (comparison)	7,15,21
Dusty contamination (application)	10	Polyoxymethylene (POM)	21	Textile industry (application)	10
Dynamic sealing systems	6	Positioning contactless and powerless (application)	11	Thermal advantages	10
Dynamic systems (applications)	11	Power loss (comparison)	7	Thermal effects (selection assistance)	12
Electronic Industry (application)	11	Powerless positioning (application)	11	Thin design, metal	18
Encoder (application)	11	Press fit	13	Thin design, plastic	24
Energy efficiency (selection sealing system)	12	Press fit (installation)	27	Throttling (function)	8
Face mounting	27	Press fit Metal	19	Tolerance table	33
Fibers (application)	11	Press fit Plastic	25	Tolerances, Metal Seal	19
Food Industry (application)	11,12	Pressure, difference of (selection sealing system)	12,13	Tolerances, Plastic Seal	25
Free of dust (product characteristic)	21	Product range Metal Seals	16,17	Type DL	18
Frictionless	15,21	Product range Plastic Seals	22,23	Type DS	24
Function	9	Product range, overview	30,31	Type L	14
Functional benefits	10	Protection against splashing liquids	29	Type M	14
Functions of seal components	8	Protective seal (application)	11	Type S, SA	20,21
Gap design	9	Quality management	34	Vertical installation	26,27,28
Gap high	9	Radial clearance Metal Seal	15	Viscosity	29
Grease, filled with (application)	10	Radial shaft seal (selection sealing system)	12	Water (selection sealing system)	12
Greased seals	21	Protecting (function)	8	Wear (comparison)	7
High temperature applications	12	Ring groove	29	Wearless (product characteristic)	15,21
Horizontal gap	9,15			Width, Metal Seal	15
				Width, Plastic Seal	21

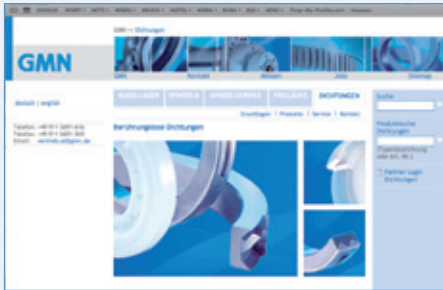

Internet

On our website www.gmn.de we provide comprehensive product information for download.

GMN

GMN Paul Müller Industrie GmbH & Co. KG manufactures non-contact seals, machine spindles, freewheel clutches and seals for many areas of application.

On the basis of long experience in the development and production of machine components, GMN has specialized in manufacturing high quality products in the area of non-contact seals and beyond a comprehensive standard product range also offers customer-oriented special solutions.

A worldwide GMN service network provides competent customer advice as well as individual solutions.



GMN Quality management – tested and certified.

GMN guarantees maximum quality of products and services on the basis of high reliability over the long term. Highly modern development and production methods safeguard products that always correspond to the state of the art. Transparency in the structure of all GMN corporate divisions as well as comprehensible organizational procedures ensure customer-oriented services and economic safety.

All GMN corporate divisions are certified according to DIN ISO 9001:2008.

GMN – safeguarding the future.

Progress means for GMN best possible customer support and performance-oriented optimization of technical products.

This aspiration is realized by GMN especially under strict observance of national and international environmental standards with regard to efficient and sustainable utilization of ecological resources.

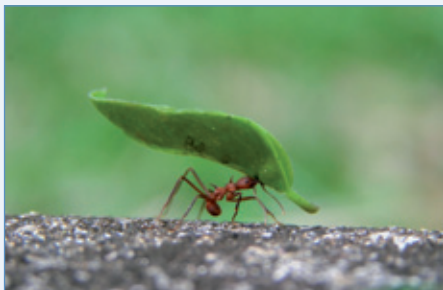

Reference

Parts of chapter “Non-Contact Seals” are based on publications of the Institute of Machine Components (IMA), University of Stuttgart.

This catalogue corresponds to the state of art at the time of printing. Technical changes, factual errors, printing errors are reserved.

Design: LMmedia, Nuremberg



GMN

High Precision Ball Bearings

Spindle Technology

Freewheel Clutches

Non-Contact Seals

GMN Paul Müller Industrie GmbH & Co. KG

Äußere Bayreuther Str. 230 · D-90411 Nuremberg

Phone: +49 911-5691-0 · Fax: +49 911-5691-221

www.gmn.de

Non-Contact Seals:

Phone: +49 (0) 911-56 91-616 · Fax: +49 911-5691-569

Mail: vertrieb.at@gmn.de

Official GMN Representative:

