

ALUMINUM WORM GEARBOXES

RIGHTANGLE GEARS

NEMA CATALOGUE EDITION 2025

C-FACE NEMA

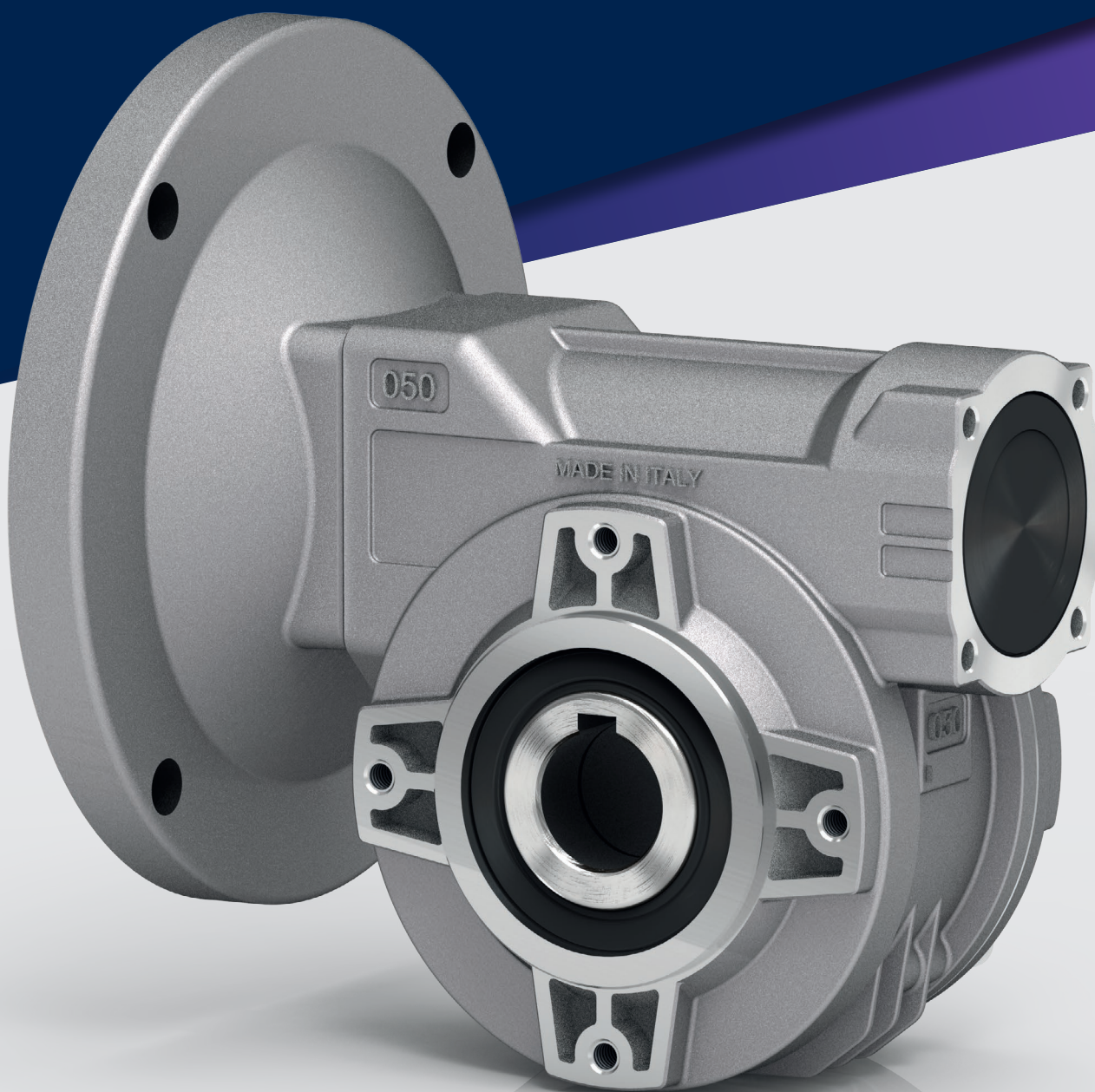

HYDRO · MEC

HIGH EFFICIENCY GEARBOXES

Worm gearboxes

A modular and compact product

Single-piece aluminum alloy housing

Is vacuum impregnated (MIL-STD 276) for protection and sealing. No secondary finish required but readily accepts paint. Combines light weight with high tensile strength. Precision machined for alignment of bearings and gearing.

Single piece alloy steel input shaft and worm shaft.

High helix angle worm is case-hardened (Rc 58-60), ground, teeth are profiled and radiused, for noise reduction and enhanced efficiency.

Oversized bearings

Support positively-retained, high speed shaft for higher shock load capacity - ideal for frequent starting and reversing application. Premium, Nitrile® high temperature seals each end.

Bronze alloy worm gears.

Is centrifugally cast onto an iron hub for maximum strength and superior life.

Oversize bearing

For radial load capability and maximum hollow output shaft diameter.

Impregnated and machined bearing caps

With exterior machined surfaces enable a variety of mounting accessories. Extra-deep thread engagement provided for greater support strength. Zinc plated hardware.

Flange

Fully modular to IEC and compact integrated motor. NEMA C flange.

Premium, high temperature

Nitrile® output seals

Standard hollow output shaft mounting

Reduces total drive envelope size, weight and cost. Single and double solid output shaft is available.

Vent Free Design.

No breather or vents to leak! Factory lubricated for life with synthetic, semi-fluid gear lubricant with an operating range of -15°C to 130°C.

oil free



vent free



World wide sales network.

Specific type datasheet on page...

On page / A pagina / En la página

1-5 1-7 1-9 1-11

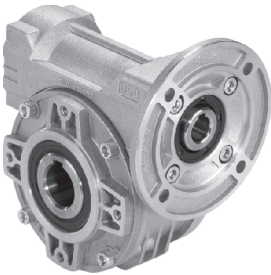

Types / tipi / Tipos →

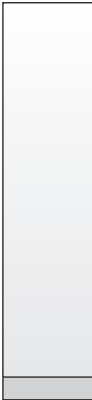

045
345 lb in

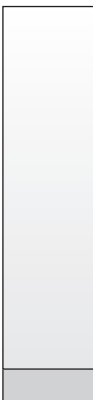

050
611 lb in

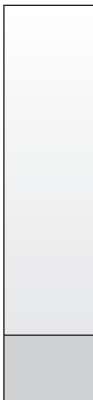

063
1240 lb in

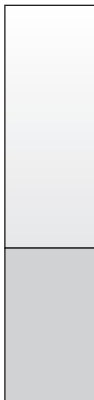

085
2921lb in

CODIFICA / HOW TO ORDER / CODIFICACIÓN

Type - Tipo

Size - Grandezza
Tamaño

Mounting - Montaggio - Tipo de montaje

P

045

PA

Worm gearboxes
Riduttori a vite senza fine
Reductores de corona sin fin

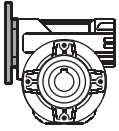

P

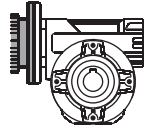

M



B

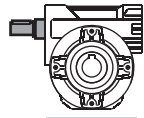

R

**045
050
063
085**

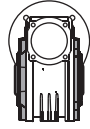

FB

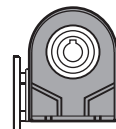

PB

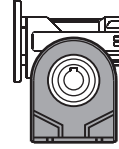

PA

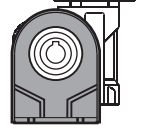

PV

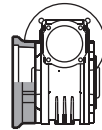

FC

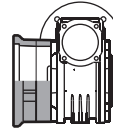





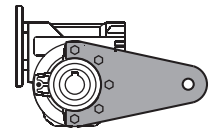

FL

**F1
F2
F3
F4**

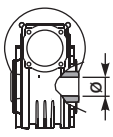
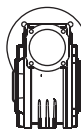
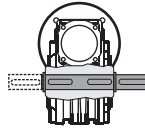
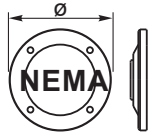
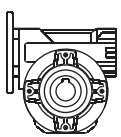
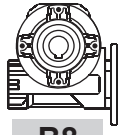
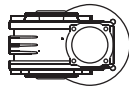
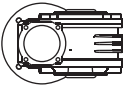
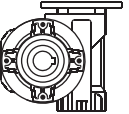
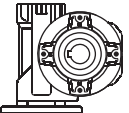
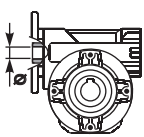

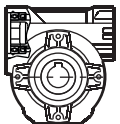
BR

CODIFICA / HOW TO ORDER / CODIFICACIÓN

Ratio Rapporto Relación	Hub Mozzo corona Nucleo corona	Output shaft Albero lento Eje solida	Motor size Grandezza motore Tamaño motor	Mounting position Posizione montaggio Position de montaje	Input bore Foro entrata Eingangshohlwelle Trou d'entree Eje hueco de entrada	Terminal box position Posizione morsettiara Posición caja de bornes
10	U	Ø	-W	B3	UW	
See technical data table Vedi tabelle dati tecnici. Ver tabla datos técnicos	 U INCH 045 ⇨ Ø0.750" 050 ⇨ Ø1.000" 063 ⇨ Ø1.125" 085 ⇨ Ø1.500" Z Stainless steel hub Mozzo in acciaio Inox Nucleo corona de acero Inox	 Ø  S	 NEMA With Flange for type P -W ⇨ 56C -X ⇨ 143/5TC -Y ⇨ 182/4TC -N without flange Senza flangia For Modular Base type B 045 ⇨ Ø0.625 050 ⇨ Ø0.625 063 ⇨ Ø0.875 085 ⇨ Ø1.125 -Z For Type - R	 B3  B8  B6  B7  V5  V6	 Standard bore UW = Ø0.625" UX = Ø0.875" UY = Ø1.125" ST standard type R Tipo R standard COUPLING  -W = Ø0.625" -X = Ø0.875" -Y = Ø1.125" -0 Ready for input coupling Predisposto per giunto 	With Type M specify terminal box position Con tipo M specificare posizione morsettiara  A  B STANDARD  C  D

POTENZA RICHIESTA / REQUIRED POWER / POTENCIA NECESARIA

Lifting / sollevamento / elevación

$$P \text{ [KW]} = \frac{M \text{ [Kg]} \cdot g \text{ [9.81]} \cdot v \text{ [m / s]}}{1000}$$

Rotation / rotazione / rotation

$$P \text{ [KW]} = \frac{M \text{ [Nm]} \cdot n \text{ [rpm]}}{9550}$$

Linear movement / traslazione / translacion

$$P \text{ [KW]} = \frac{F \text{ [N]} \cdot v \text{ [m / s]}}{1000}$$

TORQUE / COPPIA / PAR

$$M \text{ [Nm]} = \frac{9550 \cdot P \text{ [KW]}}{n \text{ [rpm]}}$$

$$M \text{ [lb in]} = \frac{63030 \cdot P \text{ [HP]}}{n \text{ [rpm]}}$$

RADIAL LOADS / CARICHI RADIALI / CARGA RADIAL Y AXIAL

- Radial load generated by external transmissions keyed onto input and/or output shafts.
- Forza radiale generata da organi di trasmissione calettati sugli alberi di ingresso e/o uscita.
- Cargas radiales, generada por transmisiones externas, aplicadas sobre los ejes de entrada y/o salida

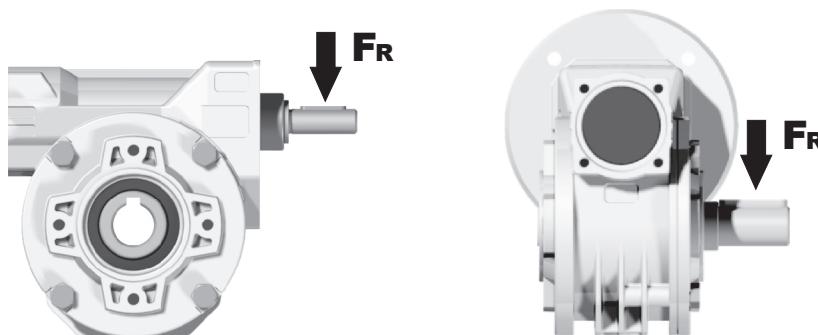

	$F_R \text{ [N]} = \frac{M \text{ [Nm]} \cdot 2000}{d \text{ [mm]}} \cdot f_k$	$F_R \text{ [N]} = \frac{M \text{ [lb in]} \cdot 8.9}{d \text{ [in]}} \cdot f_k$
M	Momento torcente / Output torque / Par torsion	
d	Diametro primitivo / Diam. of driving element / Diámetro primitivo	
f_k	Coefficiente di trasformazione / Factor / Coeficiente de transmisión 1.15 Ingranaggi / Gearwheels / Engranaje 1.25 Catena / Chain sprockets / Cadena 1.75 Cinghia Trapezoidale / Narrow v-belt pulley / Correa trapezoidal 2.50 Cinghia piatta / Flat-belt pulley / Correa plana	

- If your application requires higher radial loads, contact our technical office. Higher load may be possible.
- Nel caso la vostra applicazione richieda carichi radiali superiori consultare il nostro ufficio tecnico, valori maggiori possono essere accettati.
- En el caso en que una aplicación exija una carga radial superior a la especificada en el catálogo, consultar a nuestra oficinas técnica.

How to select a gearbox / Come selezionare un riduttore Cómo seleccionar un reductor

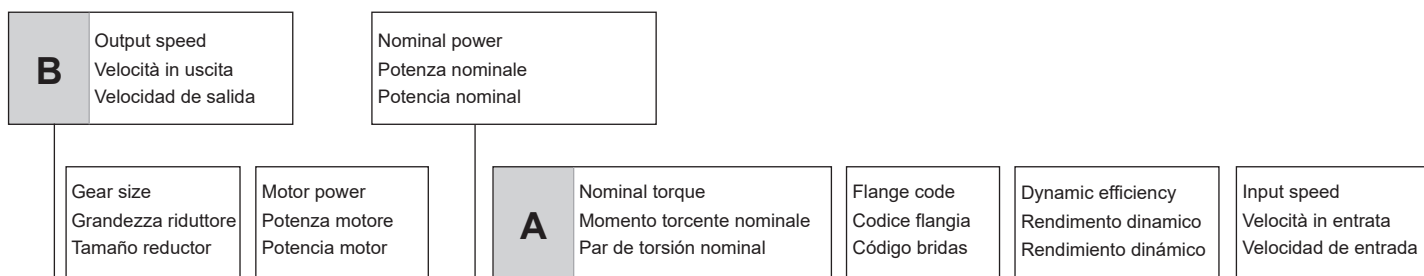

045 Rightangle - Gear 345lb in

Rating - Alluminum WORM GEARBOXES



QUICK SELECTION / Selezione veloce

input speed (n₁) = 1750 min⁻¹

Output Speed n ₂ [min ⁻¹]	Ratio i	Motor power P _{1M} [HP]	Output torque M _{2M} [lb in]	Service factor f.s.	Nominal power P _{1R} [HP]	Nominal torque M _{2R} [lb in]	Available NEMA motor flanges	Dynamic efficiency RD	Tooth Module [mm]	Ratios code
250.0	7	1	202	1.3	1.29	257	-W	80	2.2	01
175.0	10	0.75	213	1.2	0.91	257	56C	79	2.2	02
125.0	14	0.5	194	1.3	0.67	257	-	77	2.4	03



Type of load and starts per hour Tipo di carico e avviamenti per ora		Oper. hours per day Ore di funz. giorn.		
		<2 h	2 - 8 h	8 - 16 h
Continuous or intermittent appl. with start / hour Applicazione cont. o interm. con n.ro operazioni/ora	Uniform / Uniforme	0.9	1	1.25
	Moderate / Moderato	1	1.25	1.5
	Heavy / Forte	1.25	1.5	1.75
Intermittent application with start / hour Applicazione intermittente con n.ro operazioni/ora	Uniform / Uniforme	1.25	1.5	1.75
	Moderate / Moderato	1.5	1.75	2
	Heavy / Forte	1.75	2	2.25

D	Motor flange available Flange disponibili Bridas disponibles	
B)	Mounting with reduction ring Montaggio con boccola di riduzione Montaje con casquillo de reducción	
C)	Motor flangeholes position/terminal box position Posizione fori flangia/basetta motore Posición agujeros brida / base motor	
B)	Available without reduction bushes Disponibile anche senza boccola Disponibile tambien sin casquillo	

A	Select required torque (according to service factor)	Seleziona la coppia desiderata (comprensiva del fattore di servizio)	Seleccionar el par deseado (incluyendo el factor de servicio)
B	Select output speed	Seleziona la velocità in uscita	Seleccionar la velocidad de salida
C	On the same line of selected geared motor, you can find the gear ratio	Sulla riga corrispondente alla motorizzazione prescelta si può rilevare il rapporto di riduzione	En la línea correspondiente al motor preseleccionado es posible encontrar la relación de reducción
D	Select motor flange available (if requested)	Scegli la flangia disponibile (se richiesta)	Seleccionar la brida disponible (sobre pedido)



QUICK SELECTION / Selezione veloce

input speed (n₁) = 1750 min⁻¹

Output Speed n ₂ [min ⁻¹]	Ratio i	Motor power P _{1M} [HP]	Output torque M _{2M} [lb in]	Service factor f.s.	Nominal power P _{1R} [HP]	Nominal torque M _{2R} [lb in]	Available NEMA motor flanges		Dynamic efficiency RD	Tooth Module [mm]	Ratios code
							-W	-			
350.0	5	1	151	1.7	1.72	257	56C	-	84	1.9	11
250.0	7	1	202	1.3	1.29	257			80	2.2	01
175.0	10	0.75	213	1.2	0.91	257			79	2.2	02
125.0	14	0.5	194	1.3	0.67	257			77	2.4	03
83.3	21	0.5	253	1.4	0.69	345			67	1.6	04
62.5	28	0.5	328	1.1	0.53	345			65	2.5	05
47.3	37	0.33	277	1.2	0.42	345			63	1.8	06
38.0	46	0.33	323	1.1	0.36	345			59	1.5	07
29.2	60	0.25	303	1.1	0.29	345			56	1.2	08
25.0	70	0.25	340	0.8	0.19	257			54	1.0	09
17.2	102	0.25*	450	<0.8	0.14	248			49	0.72	10

A) Motor Flanges Available
Flange Motore Disponibili

B) Supplied with Reduction Bushing
Fornito con Bussola di Riduzione

B) Available on Request without reduction bushing
Disponibile a Richiesta senza Bussola di Riduzione

C) Motor Flange Holes Position
Posizione Fori Flangia Motore

* Power higher than the maximum one which can be supported by the gearbox. Select according to the torque M_{2R}
Potenza superiore a quella massima sopportabile dal riduttore. Selezionare in base al momento torcente M_{2R}

EN Unit 045 is supplied with synthetic oil, providing "long life" lubrication. For mounting position V5-V6 please contact us. See table 1 for lubrication and recommended quantity. In table 2 please see possible radial loads and axial loads on the gearbox. [For complete documentation please visit our web site.](#)

I Il riduttore tipo 045 viene fornito lubrificato a vita con olio sintetico. Per posizioni V5-V6 contattare il ns. servizio tecnico. Vedi tab.1 per oli e quantità consigliati. In tab.2 sono presenti i carichi radiali e assiali applicabili al riduttore. [Per la documentazione completa consulta il nostro sito.](#)

E El reductor tamaño 045 se suministra, lubricado de por vida con aceites sintético. Para las posiciones V5 y V6 contactar con nuestro servicio técnico. Ver tabla 1, para cantidades y aceites recomendados. En la tabla 2, se encuentran las cargas radiales y axiales admitidas por el reductor. [Para documentación completa, consultar nuestra Web.](#)

LUBRICATION 045 Oil Quantity 3.17 ounces

SHELL Omala S4 WE 320

ENI Telium VSF 320

For all details on lubrication and plugs check our website **tab. 1**
Per maggiori dettagli su lubrificazione e tappi olio vedi il nostro sito web

RADIAL AND AXIAL LOADS

Output shaft

Albero di uscita

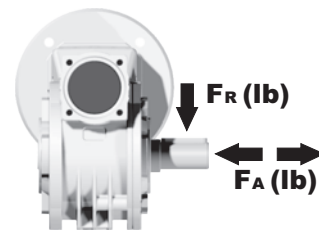

n ₂ [min ⁻¹]	FA [lb]	FR [lb]
200	40	202
150	45	225
100	49	247
75	54	270
50	58	315
25	67	405
15	90	450

Input shaft

albero in entrata

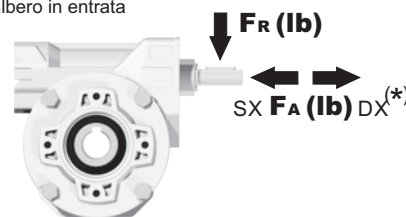

n ₁ [min ⁻¹]	FA [lb]	FR [lb]
1750	9	47

*Strong axial loads in the DX direction are not allowed.
Non sono consentiti forti carichi assiali con direzione DX

tab. 2

P045**FB**... Basic wormbox
Riduttore base

Gearbox weight
peso riduttore **5.30 lb**

M. flanges	Kit code	øF	A
56C	KU050.4.041	6.5	3.709

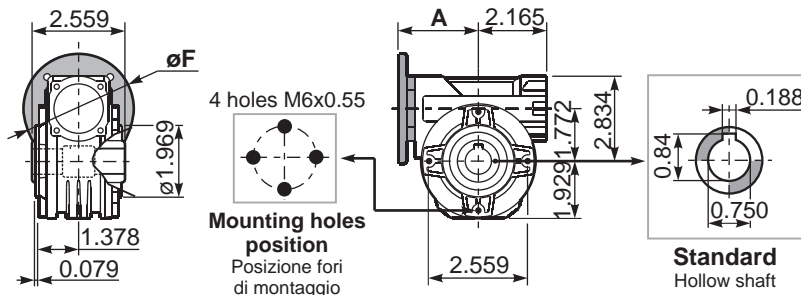

P045**PA**... Feet
Piedini

P045**PB**... Feet
Piedini

P045**PV**... Feet
Piedini

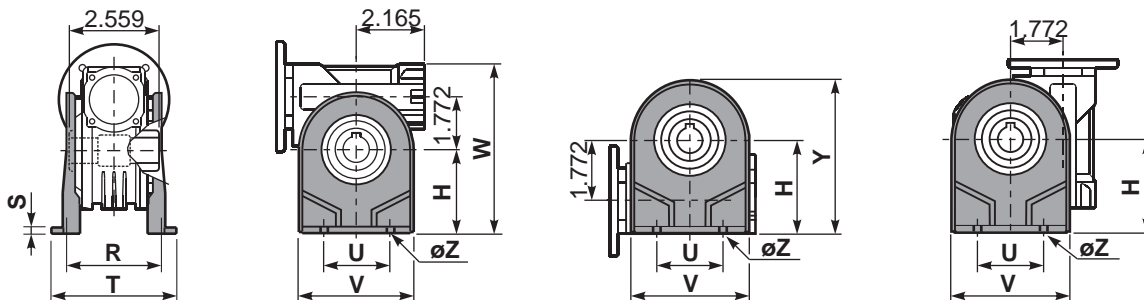

	H	R	S	T	U	V	Y	W	øZ	kit code
type B	2.835	3.189	0.118	3.937	2.047	3.858	4.764	5.669	0.41	K045.9.022
type S	2.795	3.307	0.315	3.937	2.756	3.543	4.724	5.630	0.31	KS045.9.023

P045**FC**... Output flange
Flangia uscita

P045**BR**... Reaction arm
Braccio di reazione

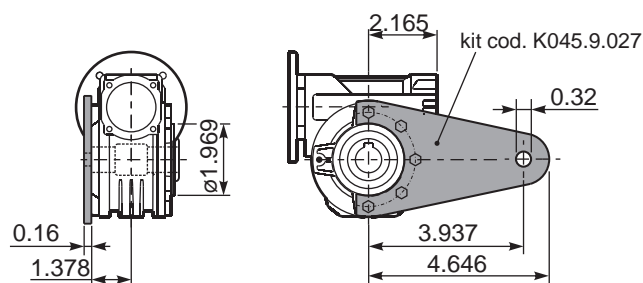
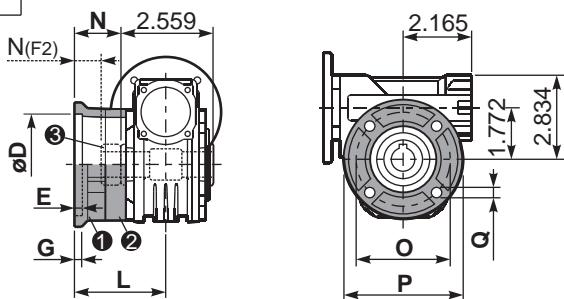

type B	øD	E	G	L	N	O	P	Q	kit code
FC	2.3681 2.3642	0.35	0.35	2.382	1.102	3.425	4.331	0.33	1 K045.9.010 2 -
FL	2.3681 2.3642	0.35	0.35	3.563	2.283	3.425	4.331	0.33	1 K045.9.010 2 K045.0.200

type S	øD	E	G	L	N	O	P	Q	kit code
F1	3.7480 3.7461	0.16	0.43	2.894	1.614	4.528	5.512	0.35	1 KS045.9.013 2 -
F2	2.3681 2.3642	0.35	0.35	2.382	0.748	3.425	4.331	0.33	1 KS045.9.010 2 S045.0.204
F3	3.1555 3.1535	0.12	0.31	2.028	0.748	3.937	4.724	0.35	1 KS045.9.014 2 -

P045.....**S**... Single Shaft
Albero lento semplice

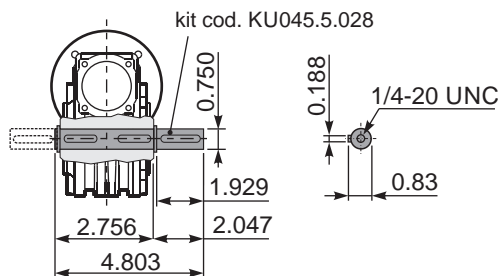

On request : Special Hollow Shafts
Mozzo Uscita Speciale



On request : Double extended worm shaft
Vite bisorgente



R045**FB**... Input shaft
Albero in entrata

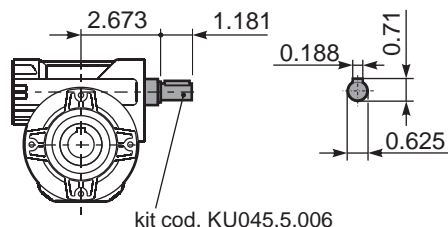

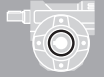

QUICK SELECTION / Selezione veloce

input speed (n₁) = 1750 min⁻¹

Output Speed n ₂ [min ⁻¹]	Ratio i	Motor power P _{1M} [HP]	Output torque M _{2M} [lb in]	Service factor f.s.	Nominal power P _{1R} [HP]	Nominal torque M _{2R} [lb in]	Available NEMA motor flanges		Dynamic efficiency RD	Tooth Module [mm]	Ratios code
							-W	-			
350.0	5	2	306	1.6	3.16	478	56C	-	RD	2.15	14
250.0	7	2	413	1.2	2.34	478			82	2.5	01
175.0	10	1.5	432	1.2	1.84	522			80	2.4	02
125.0	14	1	398	1.4	1.46	575			79	2.6	03
97.2	18	1	486	1.1	1.09	522			75	2.0	04
67.3	26	0.75	485	1.2	0.87	558			69	2.7	05
58.3	30	0.75	567	1.1	0.82	611			70	2.5	12
48.6	36	0.5	447	1.4	0.69	611			69	2.1	06
40.7	43	0.5	511	1.1	0.57	575			66	1.8	07
35.0	50	0.5	558	1.0	0.51	558			62	1.5	13
29.2	60	0.33	414	1.3	0.42	522			58	1.3	08
25.7	68	0.33	461	1.1	0.35	487			57	1.2	09
21.9	80	0.25	389	1.2	0.31	478			54	1.0	10
17.5	100	0.25	450	1.0	0.24	434			50	0.8	11

A) Motor Flanges Available
Flange Motore Disponibili

B) Supplied with Reduction Bushing
Fornito con Bussola di Riduzione

B) Available on Request without reduction bushing
Disponibile a Richiesta senza Bussola di Riduzione

C) Motor Flange Holes Position
Posizione Fori Flangia Motore

EN Unit 050 is supplied with synthetic oil, providing "long life" lubrication. For mounting position V5-V6 please contact us. See table 1 for lubrication and recommended quantity. In table 2 please see possible radial loads and axial loads on the gearbox. For complete documentation please visit our web site.

I Il riduttore tipo 050 viene fornito lubrificato a vita con olio sintetico. Per posizioni V5-V6 contattare il ns. servizio tecnico. Vedi tab.1 per oli e quantità consigliati. In tab.2 sono presenti i carichi radiali e assiali applicabili al riduttore. Per la documentazione completa consulta il nostro sito.

E El reductor tamaño 050 se suministra, lubricado de por vida con aceites sintético. Para las posiciones V5 y V6 contactar con nuestro servicio técnico. Ver tabla 1, para cantidades y aceites recomendados. En la tabla 2, se encuentran las cargas radiales y axiales admitidas por el reductor. Para documentación completa, consultar nuestra Web.

LUBRICATION 050 Oil Quantity 4.93 ounces

SHELL Omala S4 WE 320	ENI Telium VSF 320
------------------------------	---------------------------

For all details on lubrication and plugs check our website **tab. 1**
Per maggiori dettagli su lubrificazione e tappi olio vedi il nostro sito web

RADIAL AND AXIAL LOADS

Output shaft

Albero di uscita

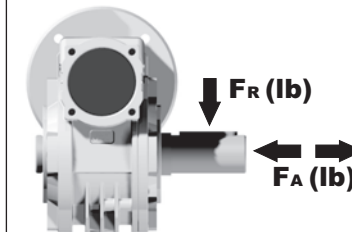

n ₂ [min ⁻¹]	FA [lb]	FR [lb]
200	54	270
150	63	315
100	67	337
75	76	382
50	85	427
25	108	562
15	126	629

Input shaft

albero in entrata

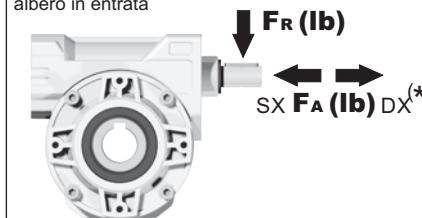

n ₁ [min ⁻¹]	FA [lb]	FR [lb]
1750	17	85

***Strong axial loads in the DX direction are not allowed.**
Non sono consentiti forti carichi assiali con direzione DX

tab. 2

P050**FB**... Basic wormbox
Riduttore base

Gearbox weight
peso riduttore **8.40 lb**

M. flanges	Kit code	øF	A
56C	KU050.4.041	6.5	3.886

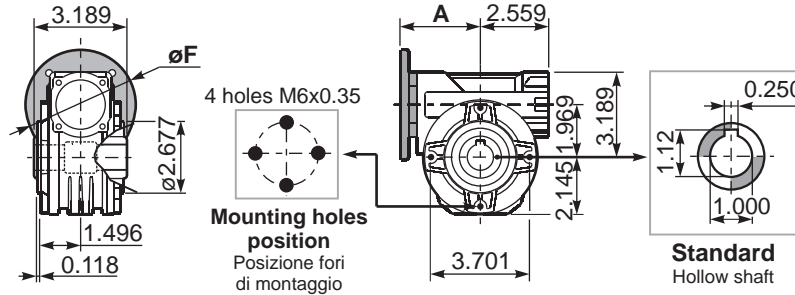

P050**PA**... Feet
Piedini

P050**PB**... Feet
Piedini

P050**PV**... Feet
Piedini

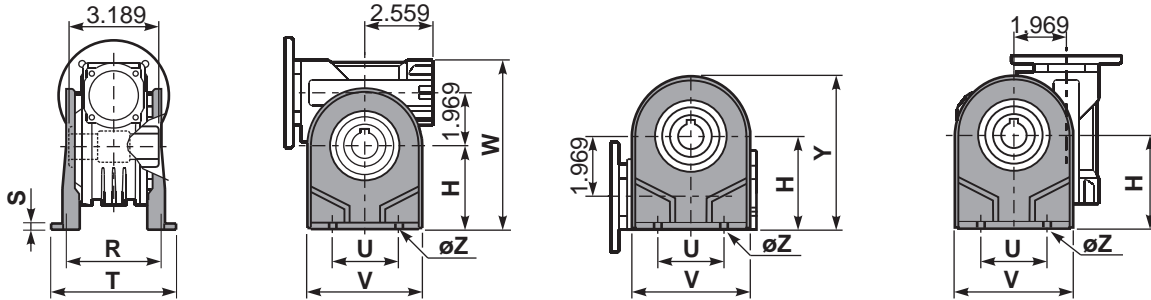

	H	R	S	T	U	V	Y	W	øZ	kit code
type B	3.228	3.878	0.138	4.843	2.480	4.449	5.453	6.417	0.41	K050.9.022
type S	3.346	3.780	0.394	4.488	3.346	4.331	5.492	6.535	0.39	KS050.9.023

P050**FC**... Output flange
Flangia uscita

P050**BR**... Reaction arm
Braccio di reazione

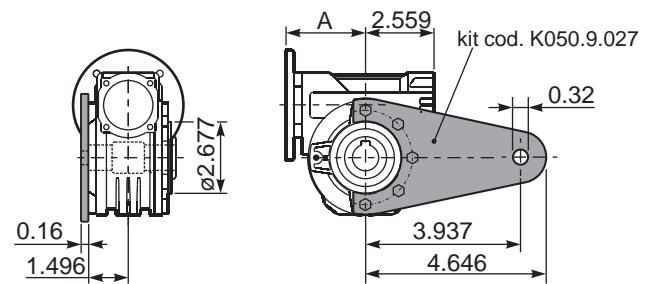
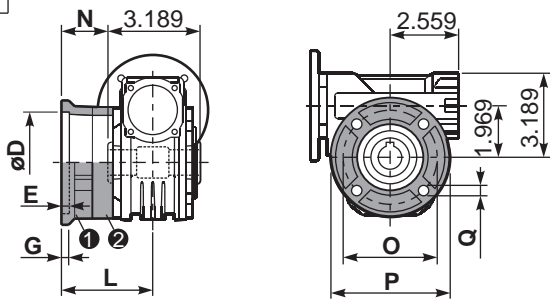

type B	øD	E	G	L	N	O	P	Q	kit code
FC	2.7638 2.7618	0.35	0.47	3.346	1.752	3.543	4.843	0.41	① K050.9.010 ② -
FL	2.7638 2.7618	0.35	0.47	4.508	2.913	3.543	4.843	0.41	① K050.9.010 ② K050.0.200

type S	øD	E	G	L	N	O	P	Q	kit code
F1	4.3386 4.3366	0.16	0.43	3.287	1.693	5.118	6.299	0.39	① KS050.9.012 ② -
F2	2.7638 2.7618	0.35	0.47	3.012	1.417	3.543	4.843	0.41	① KS050.9.014 ② -
F3	3.7415 3.7402	0.16	0.39	2.618	1.024	4.528	5.512	0.39	① KS050.9.013 ② -

P050.....**S**... Single Shaft
Albero lento semplice

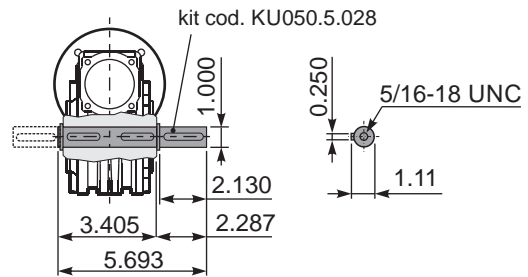

On request : Special Hollow Shafts
Mozzo Uscita Speciale



On request : Double extended worm shaft
Vite bisporgente



R050**FB**... Input shaft
Albero in entrata

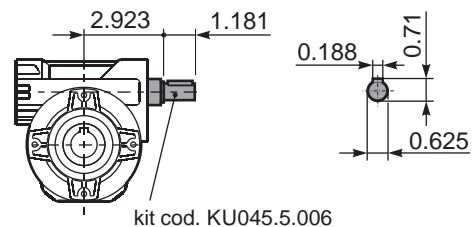



QUICK SELECTION / Selezione veloce

input speed (n_1) = 1750 min⁻¹

Output Speed n_2 [min ⁻¹]	Ratio i	Motor power P_{1M} [HP]	Output torque M_{2M} [lb in]	Service factor f.s.	Nominal power P_{1R} [HP]	Nominal torque M_{2R} [lb in]	Available NEMA motor flanges		Dynamic efficiency RD	Tooth Module [mm]	 Ratios code
							-W 56C	-X 143-5TC			
250.0	7	2	419	2.5	5.10	1053	B		83	3.1	01
175.0	10	2	583	1.9	3.93	1133	B		81	3.1	02
116.7	15	2	854	1.4	2.75	1159	B		79	3.1	03
92.1	19	2	1068	1.1	2.20	1159	B		78	2.6	04
72.9	24	1.5	972	1.2	1.87	1195	B		75	2.0	05
58.3	30	1.5	1199	1.0	1.56	1230	B		74	3.2	06
48.6	36	1	882	1.4	1.42	1239	B		68	2.7	07
43.8	40	1	951	1.2	1.25	1177	B		66	2.5	13
38.9	45	1	1070	1.1	1.08	1142	B		66	2.1	08
29.2	60	0.75	1005	1.1	0.83	1097	B		62	1.6	12
26.1	67	0.5	724	1.4	0.73	1044	B		60	1.5	09
21.9	80	0.5	821	1.2	0.62	1000	B		57	1.3	10
18.6	94	0.5	880	1.1	0.58	1000	B		52	1.1	11

Motor Flanges Available
Flange Motore Disponibili

B) Supplied with Reduction Bushing
Fornito con Bussola di Riduzione

B) Available on Request without reduction bushing
Disponibile a Richiesta senza Bussola di Riduzione

C) Motor Flange Holes Position
Posizione Fori Flangia Motore

EN Unit 063 is supplied with synthetic oil, providing "long life" lubrication. For mounting position V5-V6 please contact us.
See table 1 for lubrication and recommended quantity. In table 2 please see possible radial loads and axial loads on the gearbox.
For complete documentation please visit our web site.

I Il riduttore tipo 063 viene fornito lubrificato a vita con olio sintetico. Per posizioni V5-V6 contattare il ns. servizio tecnico.
Vedi tab.1 per oli e quantità consigliati. In tab.2 sono presenti i carichi radiali e assiali applicabili al riduttore.
Per la documentazione completa consulta il nostro sito.

E El reductor tamaño 063 se suministra, lubricado de por vida con aceite sintético. Para las posiciones V5 y V6 contactar con nuestro servicio técnico.
Ver tabla 1, para cantidades y aceites recomendados. En la tabla 2, se encuentran las cargas radiales y axiales admitidas por el reductor.
Para documentación completa, consultar nuestra Web.

LUBRICATION 063 Oil Quantity 14.08 ounces

SHELL Omala S4 WE 320

ENI Telium VSF 320

For all details on lubrication and plugs check our website **tab. 1**
Per maggiori dettagli su lubrificazione e tappi olio vedi il nostro sito web

RADIAL AND AXIAL LOADS

Output shaft Albero di uscita

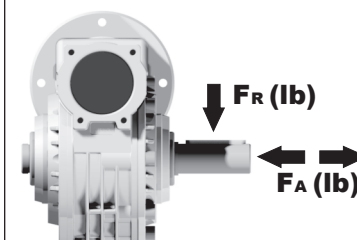

n_2 [min ⁻¹]	FA [lb]	FR [lb]
200	81	404.5
150	90	450
100	103.5	517
75	112.5	562
50	135	674.5
25	157	854
15	180	899

Input shaft albero in entrata

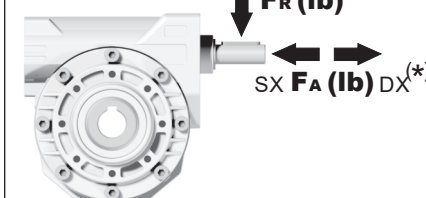

n_1 [min ⁻¹]	FA [lb]	FR [lb]
1750	20	101

***Strong axial loads in the DX direction are not allowed.**
Non sono consentiti forti carichi assiali con direzione DX

tab. 2

P063FB... Basic wormbox
Riduttore base

Gearbox weight
peso riduttore **13.23 lb**

M. flanges	Kit code	øF	A
56C	KU063.4.041	6.50	4.409
143/5 TC	KU063.4.041	6.50	4.409

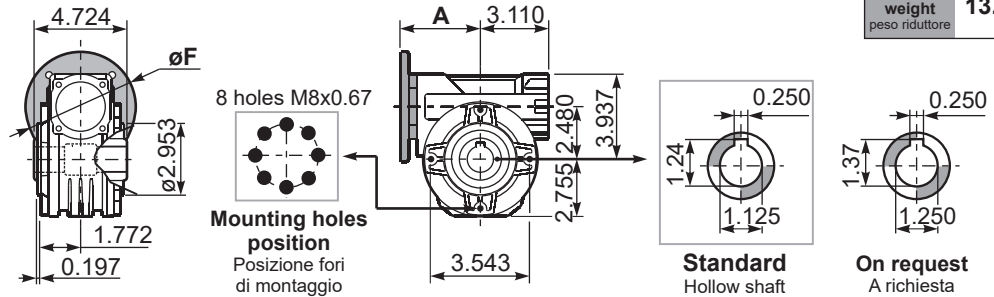

P063PA... Feet
Piedini

P063PB... Feet
Piedini

P063PV... Feet
Piedini

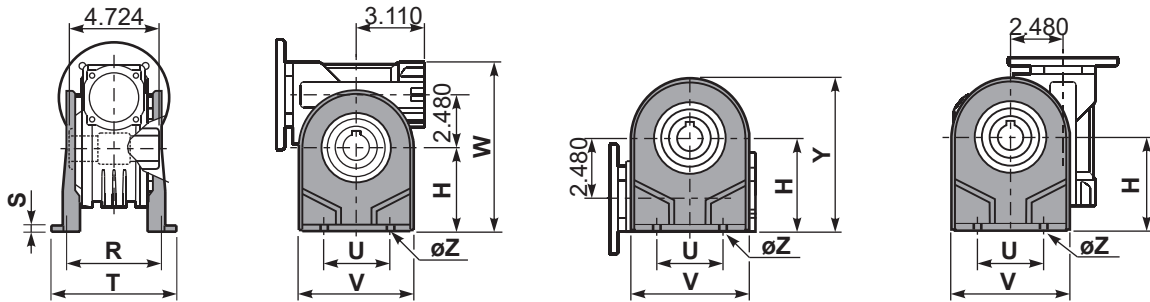

	H	R	S	T	U	V	Y	W	øZ	kit code
type B	3.937	4.370	0.157	5.669	3.740	5.236	6.693	7.874	0.41	K063.9.022
type S	-	-	-	-	-	-	-	-	-	-

P063FC... Output flange
Flangia uscita

P063BR... Reaction arm
Braccio di reazione

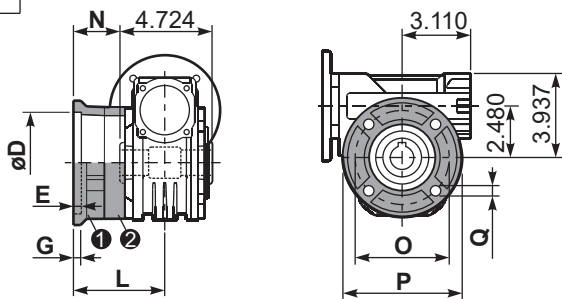

type B	øD	E	G	L	N	O	P	Q	kit code
FC	4.5354 4.5335	0.28	0.51	3.386	1.024	5.906	6.890	0.43	① K063.9.010 ② -
FL	4.5354 4.5335	0.28	0.51	4.567	2.205	5.906	6.890	0.43	① K063.9.010 ② K063.0.200

type S	øD	E	G	L	N	O	P	Q	kit code
F1	5.1260 5.1240	0.28	0.51	4.016	1.654	6.496	7.874	0.51	① KS070.9.013 ② -
F2	4.5354 4.5354	0.28	0.51	4.567	2.205	5.906	6.890	0.43	① KS063.9.013 ② -
F3	4.3321 4.3307	0.20	0.43	3.228	0.866	5.118	6.299	0.39	① KS063.9.011 ② -

P063.....S... Single Shaft
Albero lento semplice

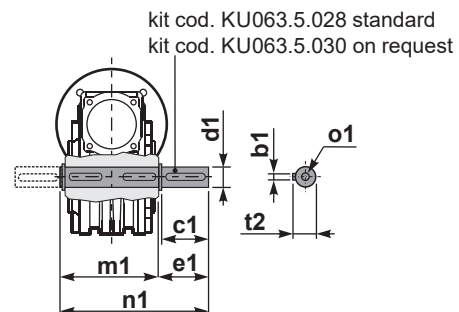

	b1	c1	d1	e1	m1	n1	t2	ø1	kit code
Standard	0.250	2.240	1.125	2.437	4.992	7.429	1.23	5/16-18	KU063.5.028
On request	0.250	2.362	1.250	2.559	4.992	7.551	1.36	5/16-18	KU063.5.030

R063FB... Input shaft
Albero in entrata

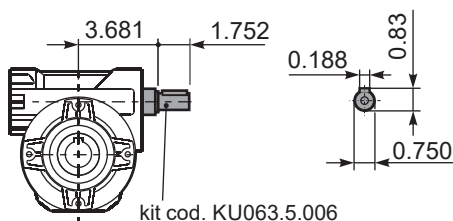

On request : Special Hollow Shafts
Mozzo Uscita Speciale



On request : Double extended worm shaft
Vite bisporgente





QUICK SELECTION / Selezione veloce

input speed (n_1) = 1750 min⁻¹

Output Speed n_2 [min ⁻¹]	Ratio i	Motor power P_{1M} [HP]	Output torque M_{2M} [lb in]	Service factor f.s.	Nominal power P_{1R} [HP]	Nominal torque M_{2R} [lb in]	Available NEMA motor flanges			Dynamic efficiency RD	Tooth Module [mm]	 Ratios code
							-W	-X	-Y			
							56C	143-5TC	182-4TC			
250.0	7	5	1109	2.0	9.90	2168	B	B		88	4.23	01
175.0	10	5	1441	1.7	8.40	2390	B	B		80	4.2	02
125.0	14	5	1967	1.3	6.61	2567	B	B		78	4.5	03
87.5	20	3	1707	1.5	4.41	2478	B	B		79	3.4	04
79.5	22	3	1854	1.3	4.06	2478	B	B		78	3.1	05
62.5	28	3	2269	1.3	3.91	2921	B	B		75	4.7	06
46.1	38	3	2915	1.0	2.95	2832	B	B		71	3.5	07
38.0	46	2	2253	1.2	2.47	2744	B	B		68	3.1	08
33.7	52	2	2472	1.0	1.99	2434	B	B		66	2.7	09
26.1	67	1.5	2353	1.0	1.57	2434	B	B		65	2.1	10
23.6	74	1.5	2319	1.0	1.48	2257	B	B		58	1.9	11
18.2	96	1	1833	1.1	1.13	2036	B	B		53	1.5	12

A) Motor Flanges Available
Flange Motore Disponibili

B) Supplied with Reduction Bushing
Fornito con Bussola di Riduzione

B) Available on Request without reduction bushing
Disponibile a Richiesta senza Bussola di Riduzione

C) Motor Flange Holes Position
Posizione Fori Flangia Motore

EN Unit 085 is supplied with synthetic oil, providing "long life" lubrication. For mounting position V5-V6 please contact us. See table 1 for lubrication and recommended quantity. In table 2 please see possible radial loads and axial loads on the gearbox. For complete documentation please visit our web site.

I Il riduttore tipo 085 viene fornito lubrificato a vita con olio sintetico. Per posizioni V5-V6 contattare il ns. servizio tecnico. Vedi tab.1 per oli e quantità consigliati. In tab.2 sono presenti i carichi radiali e assiali applicabili al riduttore. Per la documentazione completa consulta il nostro sito.

E El reductor tamaño 085 se suministra, lubricado de por vida con aceite sintético. Para las posiciones V5 y V6 contactar con nuestro servicio técnico. Ver tabla 1, para cantidades y aceites recomendados. En la tabla 2, se encuentran las cargas radiales y axiales admitidas por el reductor. Para documentación completa, consultar nuestra Web.

LUBRICATION 085 Oil Quantity 42.23 ounces

SHELL Omala S4 WE 320

ENI Telium VSF 320

For all details on lubrication and plugs check our website **tab. 1**
Per maggiori dettagli su lubrificazione e tappi olio vedi il nostro sito web

RADIAL AND AXIAL LOADS

Output shaft

Albero di uscita

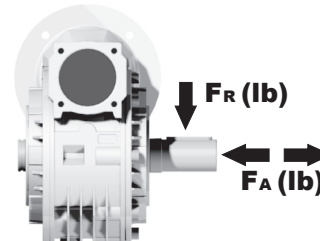

n_2 [min ⁻¹]	FA [lb]	FR [lb]
200	112	562
150	130	652
100	135	674
75	157	787
50	180	899
25	225	1124
15	261	1304

Input shaft

albero in entrata

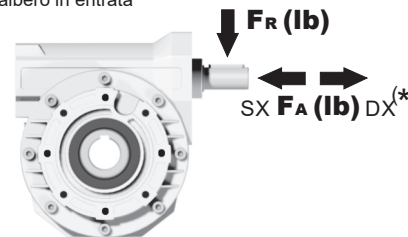

n_1 [min ⁻¹]	FA [lb]	FR [lb]
1750	29	146

***Strong axial loads in the DX direction are not allowed.**
Non sono consentiti forti carichi assiali con direzione DX

tab. 2

P085FB... Basic wormbox
Riduttore base

Gearbox weight
peso riduttore **24.25 lb**

M. flanges	Kit code	øF	A
56C	KU085.4.041	6.50	4.823
143/5 TC	KU085.4.041	6.50	4.823
182/4 TC	KU085.4.042	8.88	5.527

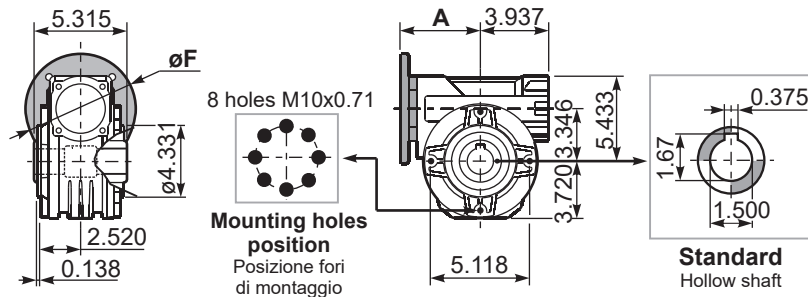

P085PA... Feet
Piedini

P085PB... Feet
Piedini

P085PV... Feet
Piedini

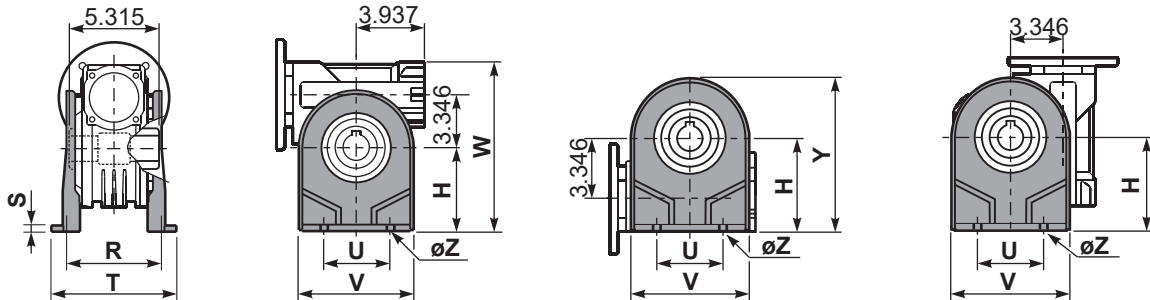

	H	R	S	T	U	V	Y	W	øZ	kit code
type B	5.591	5.709	0.197	7.165	5.512	7.087	9.311	11.024	0.41	K085.9.022
type S	-	-	-	-	-	-	-	-	-	-

P085FC... Output flange
Flangia uscita

P085BR... Reaction arm
Braccio di reazione

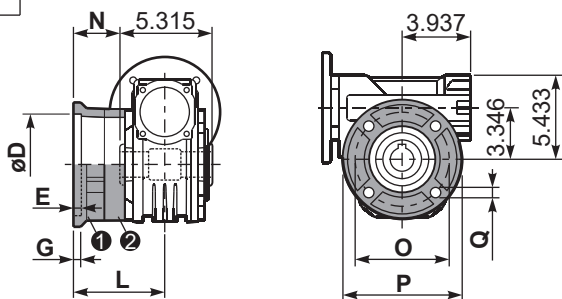

type B	øD	E	G	L	N	O	P	Q	kit code
FC	5.9867 5.9843	0.20	0.63	4.252	1.594	6.929	8.071	0.51	① K085.9.010 ② -
FL	5.9867 5.9843	0.20	0.63	5.846	3.189	6.929	8.071	0.51	① K085.9.010 ② K085.0.201

type S	øD	E	G	L	N	O	P	Q	kit code
F1	5.1197 5.1181	0.20	0.51	4.626	1.969	6.496	7.874	0.45	① KS085.9.012 ② -
F2	5.9867 5.9843	0.20	0.59	5.807	3.150	7.087	8.071	0.49	① KS085.9.013 ② -
F4	5.1197 5.1181	0.20	0.51	4.193	1.535	6.496	7.874	0.51	① KS085.9.015 ② -

P085.....S... Single Shaft
Albero lento semplice

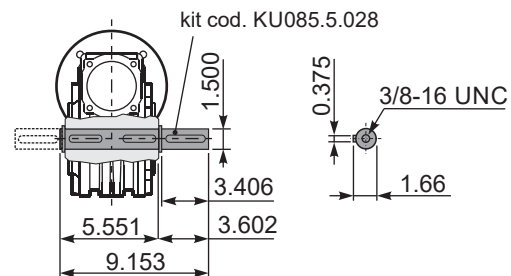

On request : Special Hollow Shafts
Mozzo Uscita Speciale



On request : Double extended worm shaft
Vite bisorgente

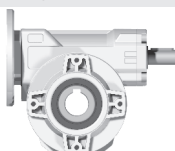

R085FB... Input shaft
Albero in entrata

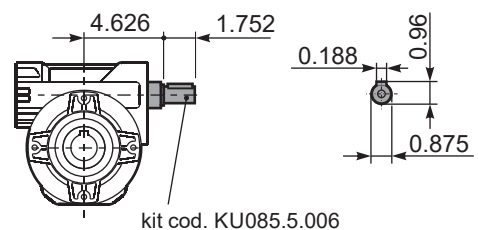

HYDROMECA SPA IS THE LEGAL RESPONSABLE FOR WARRANTY ISSUES.

PLEASE READ CAREFULLY

The following WARNING and CAUTION information are supplied to you for the proper functioning of your product.

Read ALL instructions prior to operating reducer.

Injury to personnel or reducer failure may be caused by improper installation, maintenance or operation.

WARNING:

- **Written authorization is required to operate or use reducers in man lift or people moving devices.**
 - Check to make sure that certain applications do not exceed the allowable load capacities published in the current catalog.
 - Buyer shall be solely responsible for determining the adequacy of the product for any and all uses to which Buyer shall apply the product. The application by Buyer shall not be subject to any implied warranty of fitness for a particular purpose.
 - For safety, Buyer or User should provide protective guards over all shaft extensions and any moving apparatus mounted thereon. The User is responsible for checking all applicable safety codes in his area and providing suitable guards. Failure to do so may result in bodily injury and/or damage to equipment.
 - Gearboxes operating in high position should have a protective shield for any possible parts falling down for casual accidents where people are moving under them.
 - Hot oil and reducers can cause severe burns. Use extreme care when removing lubrication plugs and vents.
 - Make certain that the power supply is disconnected before attempting to service or remove any components. Lock out the power supply and tag it to prevent unexpected application power.
 - Reducers are not to be considered fail safe or self-locking devices. If these features are required, a properly sized, independent holding device should be utilized.
- Reducers should not be used as a brake.
- Any brakes that are used in conjunction with a reducer must be sized or positioned in such a way so as to not subject the reducer to loads beyond the catalog rating.
 - Lifting supports including eyebolts are to be used for vertically lifting the gearbox only and not other associated attachments or motors.
 - Use of an oil with an EP additive on units with backstops may prevent proper operation of the backstop. Injury to personnel, damage to the reducer or other equipment may result.
 - Overhung loads subject shaft bearings and shafts to stress which may cause premature bearing failure and or shaft breakage from bending fatigue, it not sized properly.

SELLING CONDITIONS

Warranty for manufacturing defects will expire one-year after the invoicing date. Hydro-Mec s.p.a. will replace or repair defective parts but will not accept any further changes for direct or indirect damages of any kind. The warranty will become null and void if repairs or changes are carried out without our prior written authorization.

Our company will not be responsible for any direct or indirect damages, caused by a wrong use of the products or for not observing the catalogue/web indication.

If the process requires total protections the customers should consider additional measures to avoid any contaminations arising from the gearboxes. All rights reserved.

All information shown in this catalogue are purely indicative;

Hydro-Mec s.p.a reserves the right to make any necessary variation without prior notice.

HYDROMECA SPA È LEGALMENTE IL RESPONSABILE DEI PROBLEMI DI GARANZIA.

LEGGERE ATTENTAMENTE

Le seguenti raccomandazioni sono fondamentali per un buon funzionamento del vostro prodotto.

Leggere attentamente tutte le istruzioni prima di azionare il riduttore.

L'inappropriata installazione, manutenzione o funzionamento del riduttore può causare incidenti al personale addetto edanni al riduttore stesso.

ATTENZIONE:

- **E' richiesta autorizzazione scritta per azionare riduttori in ascensori o dispositivi per il movimento delle persone.**
- Controllare che alcune applicazioni non eccedano la massima capacità di carico ammessa pubblicata in questo catalogo.
- L'acquirente è l'unico responsabile per la determinazione dell'adeguatezza del prodotto per qualcuna o tutte le utilizzazioni che l'acquirente stesso farà del riduttore. L'applicazione dell'acquirente non potrà essere soggetta ad alcuna implicita garanzia di montaggio per uno scopo particolare.
- Per ragioni di sicurezza l'acquirente dovrà provvedere a porre protezioni adeguate su tutta la lunghezza dell'albero a tutti gli organi in movimento. L'utilizzatore è responsabile del controllo di tutti i codici di sicurezza e la predisposizione di protezioni adeguate. In assenza di tali precauzioni si possono verificare incidenti alle persone e danni agli apparati.
- Su riduttori installati in posizioni elevate utilizzare protezioni adeguate per qualsiasi distacco accidentale di parti nel caso di passaggio di persone al di sotto.
- Olio e riduttori bollenti possono causare gravi ustioni. Usare estrema cautela nella rimozione dei tappi e delle ventole.
- Assicurarsi che la corrente di alimentazione sia scollegata prima di riparare o rimuovere alcun componente. Chiudere l'alimentazione e contrassegnare tale operazione per evitare accensioni accidentali.
- I riduttori non devono essere considerati esenti da guasti o a bloccaggio automatico. Se sono indispensabili queste caratteristiche, deve essere utilizzato un dispositivo indipendente della dimensione adatta. I riduttori non devono essere utilizzati come freni.
- Qualsiasi freno sia utilizzato insieme al riduttore deve essere della giusta grandezza e posizionato in modo da non causare carichi eccessivi non previsti dai dati forniti nel catalogo.
- I dispositivi di sollevamento come le golfare devono essere usati solo per sollevare verticalmente il riduttore e non altri dispositivi associati o motori.
- L'utilizzo di un olio con un additivo EP su gruppi provvisti di dispositivo di arresto possono inficiare l'uso corretto del freno e provocare danni alle persone, alle cose ed al riduttore stesso nonché ad altri apparecchi.
- I Carichi sospesi assoggettano i cuscinetti della vite e la vite stessa a sollecitazioni che possono causare, se non adeguatamente dimensionati, l'usura prematura dei cuscinetti e/o l'arrotatura della vite a causa della resistenza alla flessione.

CONDIZIONI DI VENDITA

La garanzia relativa a difetti di costruzione ha la durata di un anno dalla data di fatturazione della merce. Tale garanzia comporta per Hydro-Mec s.p.a. l'onere della sostituzione o riparazione delle parti difettose ma non ammette ulteriori addebiti per eventuali danni diretti o indiretti di qualsiasi natura. La garanzia decade nel caso in cui siano state eseguite riparazioni o apportate modifiche senza nostro consenso scritto.

La nostra ditta non si ritiene responsabile per eventuali danni diretti o indiretti derivanti da un uso improprio dei prodotti e dalla mancata osservanza delle indicazioni riportate a catalogo o web.

Se il processo richiede una protezione totale, i clienti dovrebbero prendere in considerazione misure aggiuntive per evitare qualsiasi contaminazione derivante dai riduttori.

Tutti i diritti sono riservati. Tutte le informazioni riportate nel presente catalogo sono puramente indicative; Hydro-Mec s.p.a si riserva il diritto di apportare qualsiasi variazione necessaria senza preavviso.

HYDRO·MEC

HIGH EFFICIENCY GEARBOXES

Via della Tecnica, 19 - 36049 Sovizzo (VI)
Tel. +39 0444551911 - Fax. +39 0444 536139
hydromec@hydromec.com

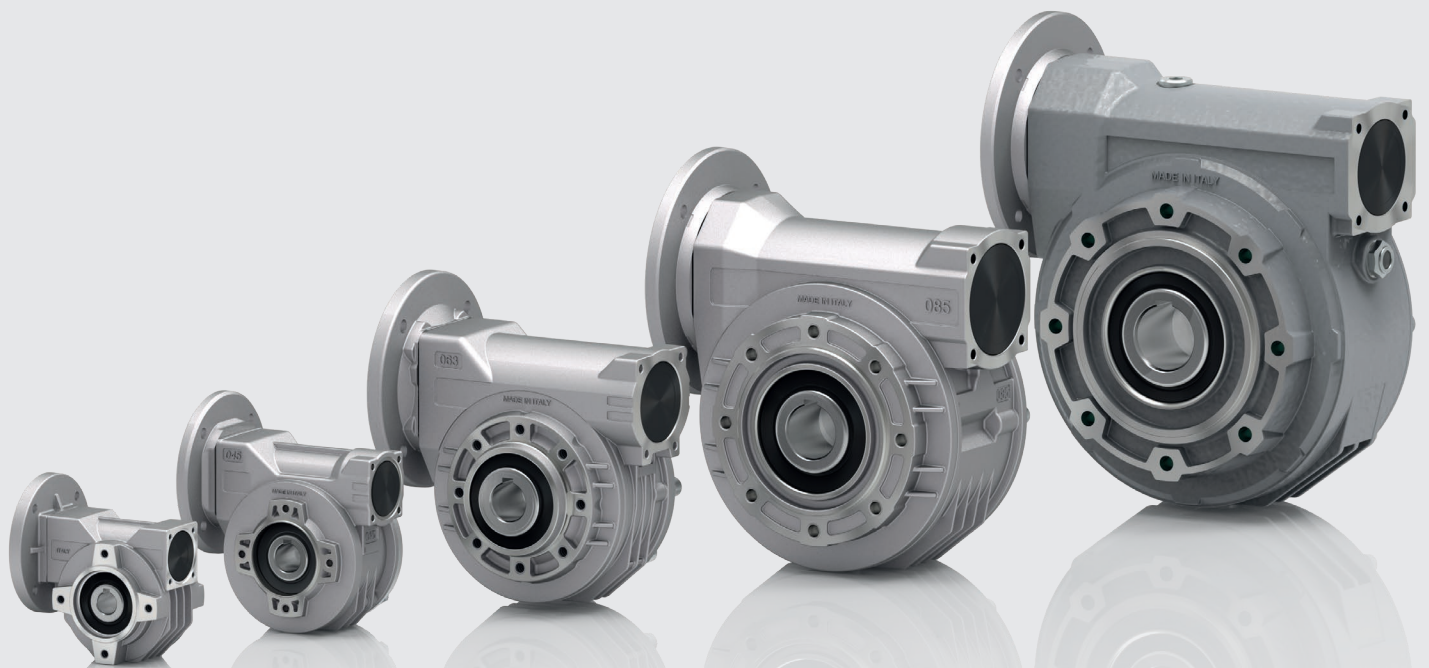

Distributed from

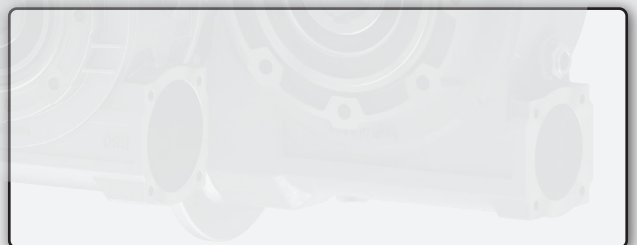

CT - WGI V S F - HM0 2 5 - ML

