

ALUMINUM WORM GEARBOXES

M SQUARE GEARS

NEMA CATALOGUE EDITION 2025

C-FACE NEMA

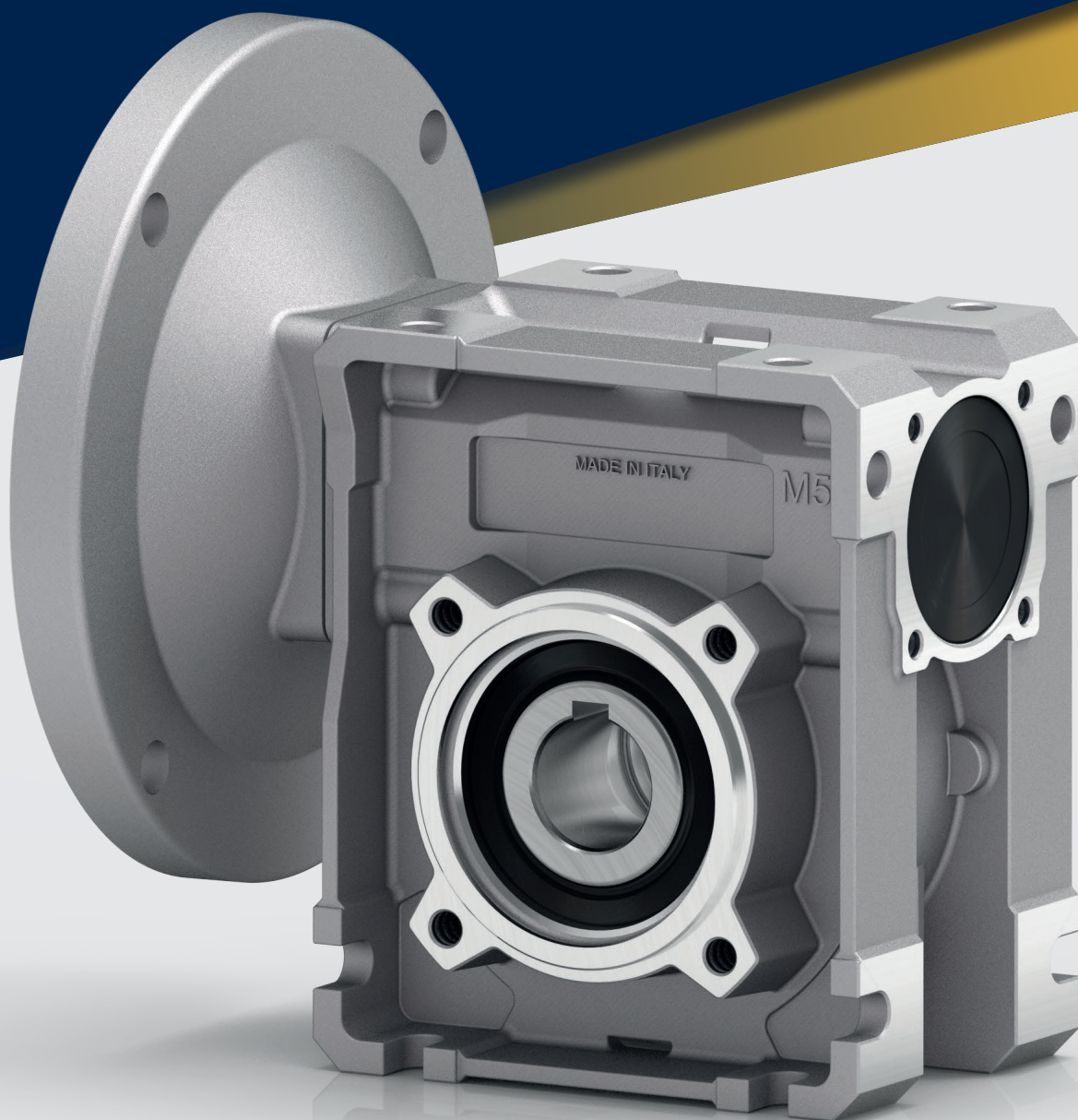

HYDRO · MEC

HIGH EFFICIENCY GEARBOXES

Worm gearboxes type M45 ÷ M85

A modular and compact product

Single-piece aluminum alloy housing

Is vacuum impregnated (MIL-STD 276) for protection and sealing. No secondary finish required but readily accepts paint. Combines light weight with high tensile strength. Precision machined for alignment of bearings and gearing.

Single piece alloy steel input shaft and worm shaft.

High helix angle worm is case-hardened (Rc 58-60), ground, teeth are profiled and radiused, for noise reduction and enhanced efficiency.

Oversized bearings

Support positively-retained, high speed shaft for higher shock load capacity - ideal for frequent starting and reversing application. Premium, Nitrile® high temperature seals each end.

Flange

Fully modular to IEC and compact integrated motor. NEMA C flange.

Premium, high temperature

Nitrile® output seals

Bronze alloy worm gears.

Is centrifugally cast onto an iron hub for maximum strength and superior life.

Oversize bearing

For radial load capability and maximum hollow output shaft diameter.

Standard hollow output shaft mounting

Reduces total drive envelope size, weight and cost. Single and double solid output shaft is available.

Impregnated and machined bearing caps

With exterior machined surfaces enable a variety of mounting accessories. Extra-deep thread engagement provided for greater support strength. Zinc plated hardware.

Vent Free Design.

No breather or vents to leak! Factory lubricated for life with synthetic, semi-fluid gear lubricant with an operating range of -15°C to 130°C.

oil free



vent free



Specific type datasheet on page...

On page / A pagina / En la página

2-5	2-7	2-9	2-11
-----	-----	-----	------

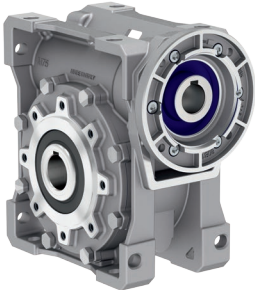

Types / tipi / Tipos →

2-5	2-7	2-9	2-11
M45 416 lb in	M50 779 lb in	M63 1416 lb in	M85 3222 lb in

Type - Tipo - Typ
Type - Tipo

Size - Grandezza
Grösse - Taille
Tamaño

Mounting - Montaggio - Montage Fixation
Fixation - Tipo de montaje

P

M45

FC

Worm gearboxes
Riduttori a vite senza fine
Schneckengetriebe
Reducteurs a vis sans fin
Reductores de corona sin fin

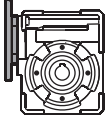

P

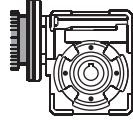

M

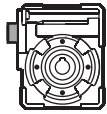

B

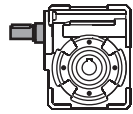

R

**M45
M50
M63
M85**

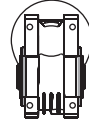

FB

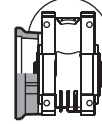

FC

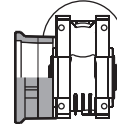





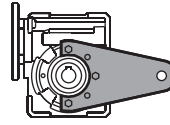

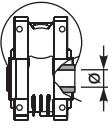
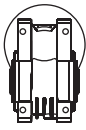
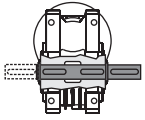
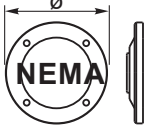

FL

**F1
F2
F3
F4**

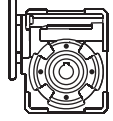
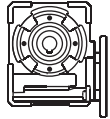
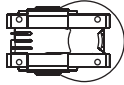
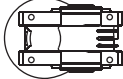
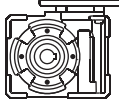
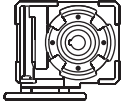
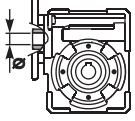

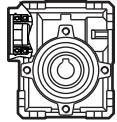
BR

CODIFICA / HOW TO ORDER / CODIFICACIÓN

Ratio Rapporto Relación	Hub Mozzo corona Nucleo corona	Output shaft Albero lento Eje solida	Motor size Grandezza motore Tamaño motor	Mounting position Posizione montaggio Position de montage	Input bore Foro entrata Eingangshohlwelle Trou d'entree Eje hueco de entrada	Terminal box position Posizione morsettiara Posición caja de bornes
10	U	Ø	-W	B3	UW	
See technical data table Vedi tabelle dati tecnici. Ver tabla datos técnicos	 <p>U INCH</p> <p>M45 ⇒ ø0.750" M50 ⇒ ø1.000" M63 ⇒ ø1.125" M85 ⇒ ø1.500"</p> <p>Z Stainless steel hub Mozzo in acciaio Inox Nucleo corona de acero Inox</p>	 <p>Ø</p>  <p>S</p>	 <p>With Flange for type P</p> <p>-W ⇒ 56C -X ⇒ 143/5TC -Y ⇒ 182/4TC</p> <p>-N without flange Senza flangia</p> <p>For Modular Base type B</p> <p>M45 ⇒ ø0.625 M50 ⇒ ø0.625 M63 ⇒ ø0.875 M85 ⇒ ø1.125</p> <p>-Z For Type - R</p> 	 <p>B3</p>  <p>B8</p>  <p>B6</p>  <p>B7</p>  <p>V5</p>  <p>V6</p>	 <p>Standard bore</p> <p>UW = ø0.625" UX = ø0.875" UY = ø1.125"</p> <p>ST standard type R Tipo R standard</p> <p>COUPLING</p>  <p>-W = ø0.625" -X = ø0.875" -Y = ø1.125"</p> <p>-0 Ready for input coupling Predisposto per giunto</p> 	<p>With Type M specify terminal box position Con tipo M specificare posizione morsettiara</p>  <p>A</p>  <p>B STANDARD</p>  <p>C</p>  <p>D</p>

POTENZA RICHIESTA / REQUIRED POWER / POTENCIA NECESARIA

Lifting / sollevamento / elevación

$$P \text{ [KW]} = \frac{M \text{ [Kg]} \cdot g \text{ [9.81]} \cdot v \text{ [m / s]}}{1000}$$

Rotation / rotazione / rotation

$$P \text{ [KW]} = \frac{M \text{ [Nm]} \cdot n \text{ [rpm]}}{9550}$$

Linear movement / traslazione / translacion

$$P \text{ [KW]} = \frac{F \text{ [N]} \cdot v \text{ [m / s]}}{1000}$$

TORQUE / COPPIA / PAR

$$M \text{ [Nm]} = \frac{9550 \cdot P \text{ [KW]}}{n \text{ [rpm]}}$$

$$M \text{ [lb in]} = \frac{63030 \cdot P \text{ [HP]}}{n \text{ [rpm]}}$$

RADIAL LOADS / CARICHI RADIALI / CARGA RADIAL Y AXIAL

- Radial load generated by external transmissions keyed onto input and/or output shafts.
- Forza radiale generata da organi di trasmissione calettati sugli alberi di ingresso e/o uscita.
- Cargas radiales, generada por transmisiones externas, aplicadas sobre los ejes de entrada y/o salida

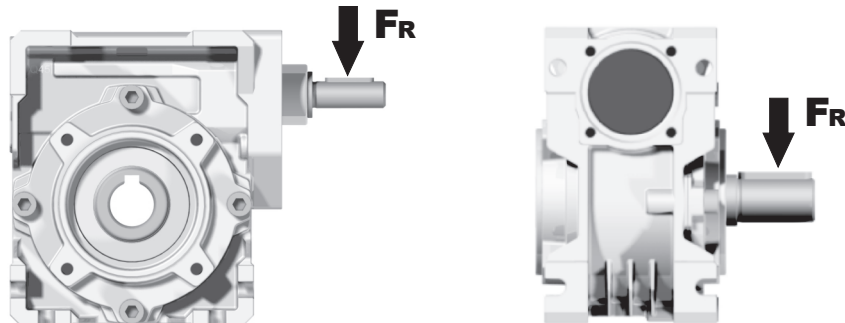

$F_R \text{ [N]} = \frac{M \text{ [Nm]} \cdot 2000}{d \text{ [mm]}} \cdot f_k$		$F_R \text{ [N]} = \frac{M \text{ [lb in]} \cdot 8.9}{d \text{ [in]}} \cdot f_k$	
M	Momento torcente / Output torque / Par torsion		
d	Diametro primitivo / Diam. of driving element / Diámetro primitivo		
f_k	Coefficiente di trasformazione / Factor / Coeficiente de transmisión 1.15 Ingranaggi / Gearwheels / Engranaje 1.25 Catena / Chain sprockets / Cadena 1.75 Cinghia Trapezoidale / Narrow v-belt pulley / Correa trapezoidal 2.50 Cinghia piatta / Flat-belt pulley / Correa plana		

- If your application requires higher radial loads, contact our technical office. Higher load may be possible.
- Nel caso la vostra applicazione richieda carichi radiali superiori consultare il nostro ufficio tecnico, valori maggiori possono essere accettati.
- En el caso en que una aplicación exija una carga radial superior a la especificada en el catálogo, consultar a nuestra oficinas técnica.

How to select a gearbox / Come selezionare un riduttore
Cómo seleccionar un reductor

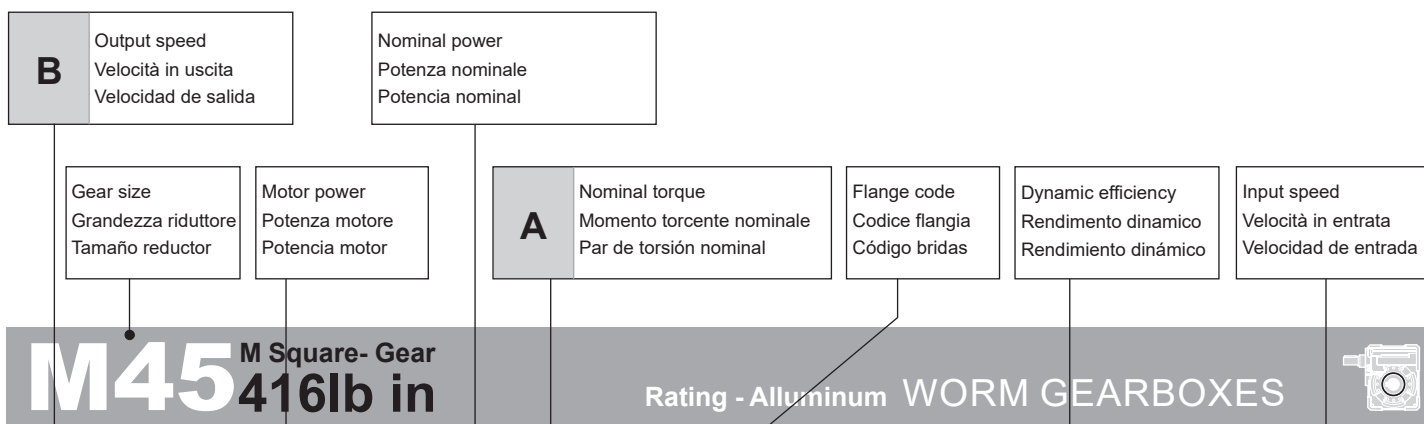

QUICK SELECTION / Selezione veloce input speed (n₁) = 1750 min⁻¹

Output Speed n ₂ [min ⁻¹]	Ratio i	Motor power P _{1M} [HP]	Output torque M _{2M} [lb in]	Service factor f.s.	Nominal power P _{1R} [HP]	Nominal torque M _{2R} [lb in]	Available NEMA motor flanges	Dynamic efficiency RD	Tooth Module [mm]	Ratios code
250.0	7	1	202	1.8	1.34	363	-W	80	2.2	01
175.0	10	1	285	1.4	1.02	389	-	79	2.2	02
125.0	14	0.75	291	1.3	0.75	389	56C	77	2.4	03



fs

Type of load and starts per hour Tipo di carico e avviamenti per ora		Oper. hours per day Ore di funz. giorn.		
		<2 h	2 - 8 h	8 - 16 h
Continuous or intermittent appl. with start / hour Applicazione cont. o interm. con n.ro operazioni/ora	Uniform / Uniforme	0.9	1	1.25
	Moderate / Moderato	1	1.25	1.5
	Heavy / Forte	1.25	1.5	1.75
Intermittent application with start / hour Applicazione intermittente con n.ro operazioni/ora	Uniform / Uniforme	1.25	1.5	1.75
	Moderate / Moderato	1.5	1.75	2
	Heavy / Forte	1.75	2	2.25

D Motor flange available
Flange disponibili
Bridas disponibles

B) Mounting with reduction ring
Montaggio con boccola di riduzione
Montaje con casquillo de reducción 

C) Motor flangeholes position/terminal box position
Posizione fori flangia/basetta motore
Posición agujeros brida / base motor 

B) Available without reduction bushes
Disponibile anche senza boccola
Disponibile tambien sin casquillo

A	Select required torque (according to service factor)	Seleziona la coppia desiderata (comprensiva del fattore di servizio)	Seleccionar el par deseado (incluyendo el factor de servicio)
B	Select output speed	Seleziona la velocità in uscita	Seleccionar la velocidad de salida
C	On the same line of selected geared motor, you can find the gear ratio	Sulla riga corrispondente alla motorizzazione prescelta si può rilevare il rapporto di riduzione	En la línea correspondiente al motor preseleccionado es posible encontrar la relación de reducción
D	Select motor flange available (if requested)	Scegli la flangia disponibile (se richiesta)	Seleccionar la brida disponible (sobre pedido)



QUICK SELECTION / Selezione veloce

input speed (n_1) = 1750 min⁻¹

Output Speed n_2 [min ⁻¹]	Ratio i	Motor power P_{1M} [HP]	Output torque M_{2M} [lb in]	Service factor f.s.	Nominal power P_{1R} [HP]	Nominal torque M_{2R} [lb in]	Available NEMA motor flanges		Dynamic efficiency RD	Tooth Module [mm]	 Ratios code
							-W	-			
350.0	5	1	151	2.0	2.07	310	56C	-	84	1.9	11
250.0	7	1	202	1.8	1.82	363			80	2.2	01
175.0	10	1	285	1.4	1.39	389			79	2.2	02
125.0	14	0.75	291	1.3	1.02	389			77	2.4	03
83.3	21	0.75	380	1.0	0.74	372			67	1.6	04
62.5	28	0.5	328	1.3	0.64	416			65	2.5	05
47.3	37	0.33	277	1.3	0.44	363			63	1.8	06
38.0	46	0.33	323	1.1	0.38	363			59	1.5	07
29.2	60	0.25	303	1.2	0.30	363			56	1.2	08
25.0	70	0.25	340	0.8	0.20	266			54	1.0	09
17.2	102	0.25*	450	<0.8	0.14	257			49	0.72	10

A) Motor Flanges Available
Flange Motore Disponibili

B) Supplied with Reduction Bushing
Fornito con Bussola di Riduzione

B) Available on Request without reduction bushing
Disponibile a Richiesta senza Bussola di Riduzione

C) Motor Flange Holes Position
Posizione Fori Flangia Motore

* Power higher than the maximum one which can be supported by the gearbox. Select according to the torque M_{2R}
Potenza superiore a quella massima sopportabile dal riduttore. Selezionare in base al momento torcente M_{2R}

EN Unit M45 is supplied with synthetic oil, providing "long life" lubrication. For mounting position V5-V6 please contact us. See table 1 for lubrication and recommended quantity. In table 2 please see possible radial loads and axial loads on the gearbox. [For complete documentation please visit our web site.](#)

I Il riduttore tipo M45 viene fornito lubrificato a vita con olio sintetico. Per posizioni V5-V6 contattare il ns. servizio tecnico. Vedi tab.1 per oli e quantità consigliati. In tab.2 sono presenti i carichi radiali e assiali applicabili al riduttore. [Per la documentazione completa consulta il nostro sito.](#)

E El reductor tamaño M45 se suministra, lubricado de por vida con aceite sintético. Para las posiciones V5 y V6 contactar con nuestro servicio técnico. Ver tabla 1, para cantidades y aceites recomendados. En la tabla 2, se encuentran las cargas radiales y axiales admitidas por el reductor. [Para documentación completa, consultar nuestra Web.](#)

LUBRICATION M45 Oil Quantity 3.17 ounces

SHELL Omala S4 WE 320

ENI Telium VSF 320

For all details on lubrication and plugs check our website **tab. 1**
Per maggiori dettagli su lubrificazione e tappi olio vedi il nostro sito web

RADIAL AND AXIAL LOADS

Output shaft

Albero di uscita

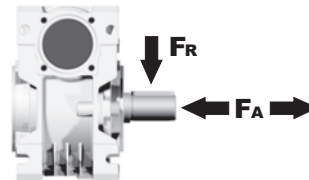

n_2 [min ⁻¹]	FA [lb]	FR [lb]
200	40	202
150	45	225
100	49	247
75	54	270
50	58	315
25	67	405
15	90	450

Input shaft

albero in entrata

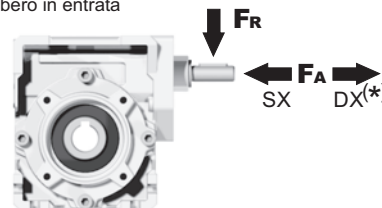

n_1 [min ⁻¹]	FA [lb]	FR [lb]
1750	9	47

*Strong axial loads in the DX direction are not allowed.
Non sono consentiti forti carichi assiali con direzione DX

tab. 2

PM45**FB**... Basic wormbox
Riduttore base

Gearbox weight
peso riduttore **5.07 lb**

M. flanges	Kit code	øF	A
56C	KU050.4.041	6.5	3.925

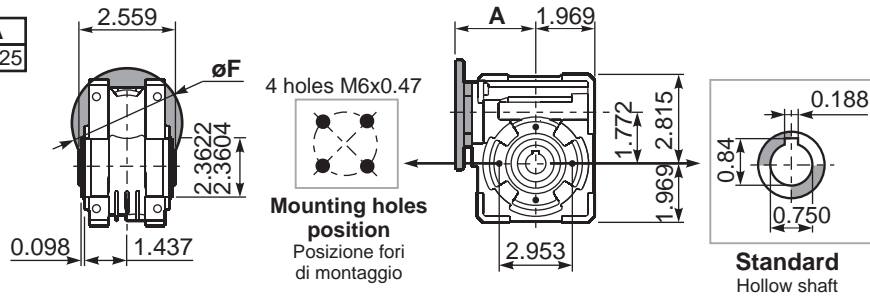

PM45**FC**... Square flange
Flangia quadrata

PM45**F1**... Round flange
Flangia rotonda

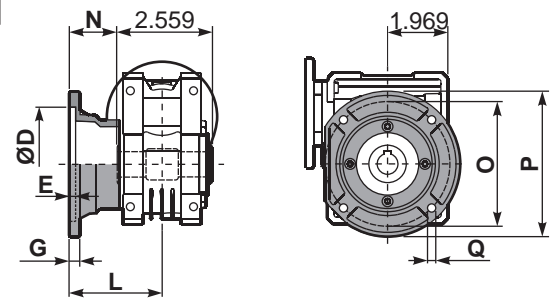
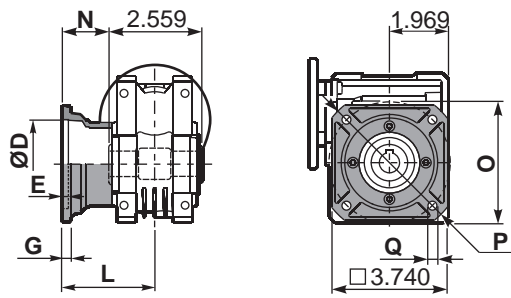

type B	øD	E	G	L	N	O	P	Q	kit code
FC	2.3640 2.3622	0.16	0.28	2.638	1.358	2.953	4.331	0.35	KM45.9.010
FL	2.3640 2.3622	0.16	0.28	3.819	2.539	2.953	4.331	0.35	KM45.9.011

type S	øD	E	G	L	N	O	P	Q	kit code
F1	3.7423 3.7402	0.20	0.35	3.150	1.870	4.528	5.512	0.37	KM45.9.012
F2	-	-	-	-	-	-	-	-	-

PM45**FB**... Feet
Piedini

PM45**BR**... Reaction arm
Braccio di reazione

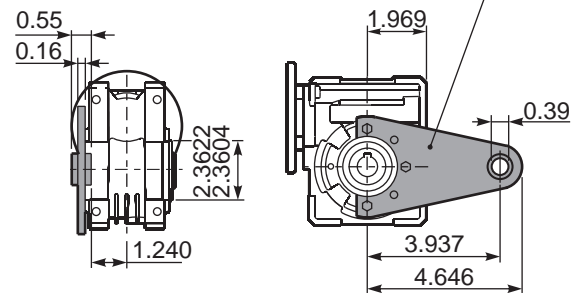
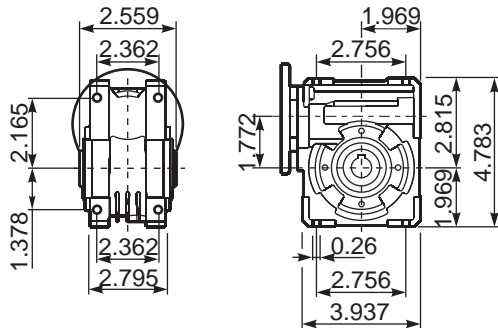

RM45**FB**... Input shaft
Albero in entrata

PM45.....**S**... Single Shaft
Albero lento semplice

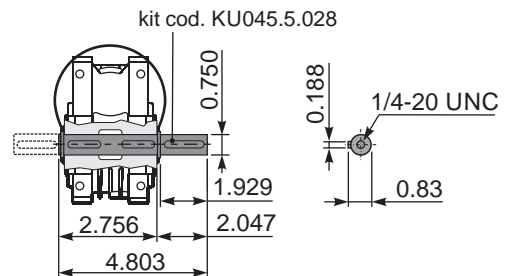
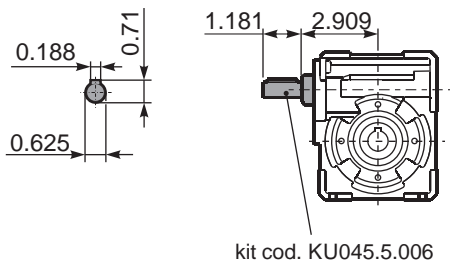

On request : Special Hollow Shafts
Mozzo Uscita Speciale



On request : Double extended worm shaft
Vite bisporgente





QUICK SELECTION / Selezione veloce

input speed (n_1) = 1750 min⁻¹

Output Speed n_2 [min ⁻¹]	Ratio i	Motor power P_{1M} [HP]	Output torque M_{2M} [lb in]	Service factor f.s.	Nominal power P_{1R} [HP]	Nominal torque M_{2R} [lb in]	Available NEMA motor flanges		Dynamic efficiency RD	Tooth Module  [mm]	 Ratios code
							-W	-			
350.0	5	2	306	1.9	3.81	575	56C	-	85	2.15	14
250.0	7	2	413	1.6	3.25	664			82	2.5	01
175.0	10	2	576	1.2	2.43	690			80	2.4	02
125.0	14	1.5	598	1.2	1.78	699			79	2.6	03
97.2	18	1	486	1.4	1.38	664			75	2.0	04
67.3	26	1	646	1.0	0.99	628			69	2.7	05
58.3	30	1	756	1.0	1.04	779			70	2.5	12
48.6	36	0.75	671	1.1	0.82	726			69	2.1	06
40.7	43	0.5	511	1.4	0.72	726			66	1.8	07
35.0	50	0.5	558	1.2	0.61	673			62	1.5	13
29.2	60	0.5	627	1.0	0.51	628			58	1.3	08
25.7	68	0.33	461	1.3	0.42	584			57	1.2	09
21.9	80	0.33	513	1.1	0.37	575			54	1.0	10
17.5	100	0.25	450	1.1	0.27	487			50	0.8	11

A) Motor Flanges Available
Flange Motore Disponibili

B) Supplied with Reduction Bushing
Fornito con Bussola di Riduzione

B) Available on Request without reduction bushing
Disponibile a Richiesta senza Bussola di Riduzione

C) Motor Flange Holes Position
Posizione Fori Flangia Motore

EN Unit M50 is supplied with synthetic oil, providing "long life" lubrication. For mounting position V5-V6 please contact us.
See table 1 for lubrication and recommended quantity. In table 2 please see possible radial loads and axial loads on the gearbox.
For complete documentation please visit our web site.

I Il riduttore tipo M50 viene fornito lubrificato a vita con olio sintetico. Per posizioni V5-V6 contattare il ns. servizio tecnico.
Vedi tab.1 per oli e quantità consigliati.
In tab.2 sono presenti i carichi radiali e assiali applicabili al riduttore.
Per la documentazione completa consulta il nostro sito.

E El reductor tamaño M50 se suministra, lubricado de por vida con aceite sintético. Para las posiciones V5 y V6 contactar con nuestro servicio técnico.
Ver tabla 1, para cantidades y aceites recomendados. En la tabla 2, se encuentran las cargas radiales y axiales admitidas por el reductor.
Para documentación completa, consultar nuestra Web.

LUBRICATION M50 Oil Quantity 4.93 ounces

SHELL Omala S4 WE 320

ENI Telium VSF 320

For all details on lubrication and plugs check our website

tab. 1

Per maggiori dettagli su lubrificazione e tappi olio vedi il nostro sito web

RADIAL AND AXIAL LOADS

Output shaft

Albero di uscita

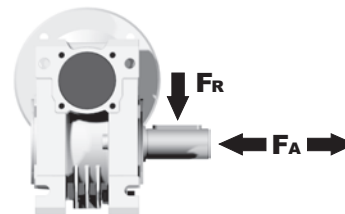

n_2 [min ⁻¹]	FA [lb]	FR [lb]
200	54	270
150	63	315
100	67	337
75	76	382
50	85	427
25	108	562
15	126	629

Input shaft

albero in entrata

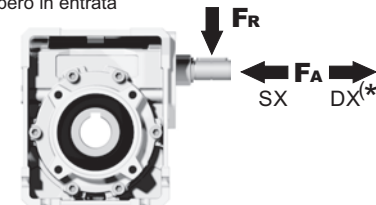

n_1 [min ⁻¹]	FA [lb]	FR [lb]
1750	17	85

***Strong axial loads in the DX direction are not allowed.**
Non sono consentiti forti carichi assiali con direzione DX

tab. 2

PM50**FB**... Basic wormbox
Riduttore base

Gearbox weight
peso riduttore **7.165 lb**

M. flanges	Kit code	øF	A
56C	KU050.4.041	6.5	4.083

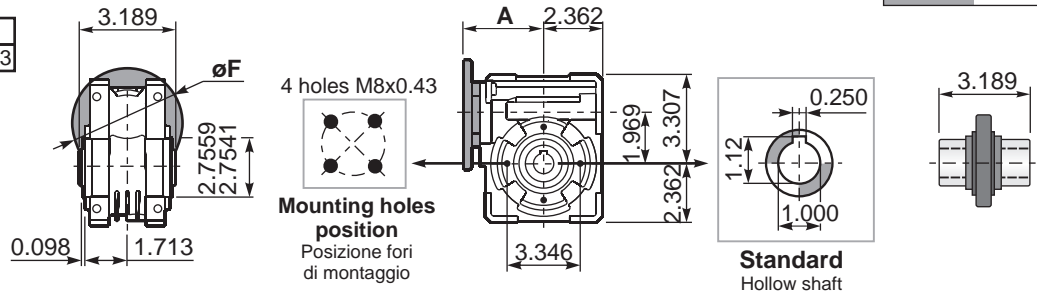

PM50**FC**... Square flange
Flangia quadrata

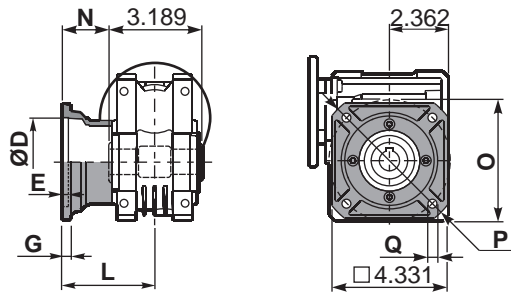

type B	øD	E	G	L	N	O	P	Q	kit code
FC	2.7577 2.7559	0.20	0.35	3.543	1.949	3.346	4.921	0.43	KM50.9.010
FL	2.7577 2.7559	0.20	0.35	4.724	3.130	3.346	4.921	0.43	KM50.9.011

PM50**F1**... Round flange
Flangia rotonda

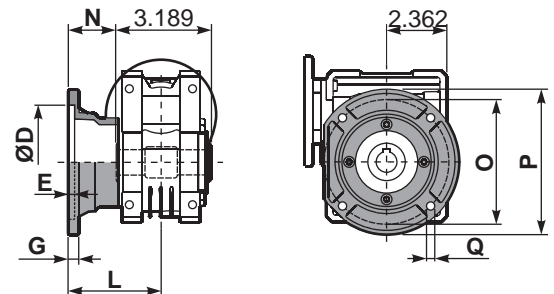

type S	øD	E	G	L	N	O	P	Q	kit code
F1	4.3328 4.3307	0.20	0.39	3.504	1.909	5.118	6.299	0.37	KM50.9.012
F2	3.7423 3.7402	0.20	0.57	2.835	1.240	4.528	5.512	0.43	KM50.9.013

PM50**FB**... Feet
Piedini

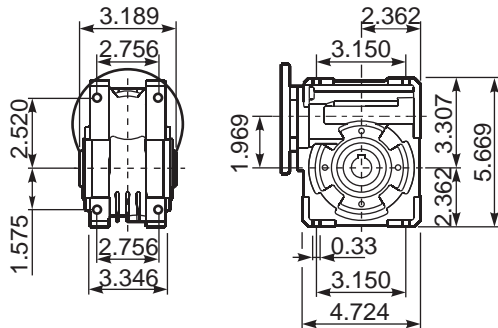

PM50**BR**... Reaction arm
Braccio di reazione

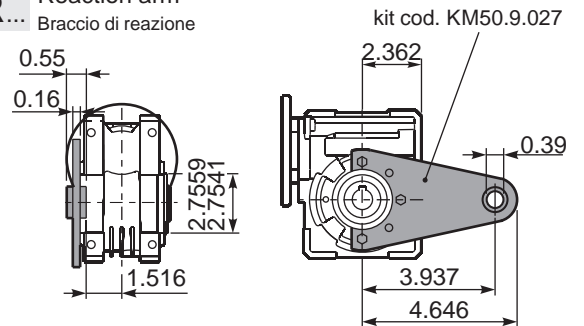

RM50**FB**... Input shaft
Albero in entrata

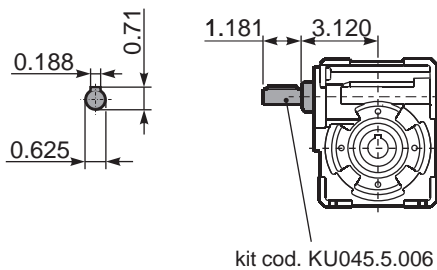

PM50.....**S**... Single Shaft
Albero lento semplice

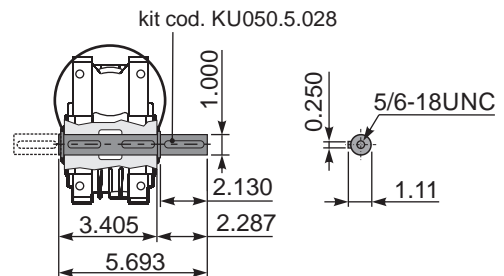

On request : Special Hollow Shafts
Mozzo Uscita Speciale



On request : Double extended worm shaft
Vite bisporgente





QUICK SELECTION / Selezione veloce

input speed (n_1) = 1750 min⁻¹

Output Speed n_2 [min ⁻¹]	Ratio i	Motor power P_{1M} [HP]	Output torque M_{2M} [lb in]	Service factor f.s.	Nominal power P_{1R} [HP]	Nominal torque M_{2R} [lb in]	Available NEMA motor flanges		Dynamic efficiency RD	Tooth Module [mm]	Ratios code
							-W	-X			
250.0	7	2	419	2.7	5.49	1133	B	143-5TC	83	3.1	01
175.0	10	2	583	2.0	4.12	1186	B		81	3.1	02
116.7	15	2	854	1.5	3.11	1310	B		79	3.1	03
92.1	19	2	1068	1.2	2.44	1283	B		78	2.6	04
72.9	24	1.5	972	1.3	1.96	1257	B		75	2.0	05
58.3	30	1.5	1199	1.2	1.79	1416	B		74	3.2	06
48.6	36	1.5	1323	1.0	1.50	1301	B		68	2.7	07
43.8	40	1	951	1.4	1.40	1310	B		66	2.5	13
38.9	45	1	1070	1.1	1.13	1195	B		66	2.1	08
29.2	60	0.75	1005	1.2	0.90	1195	B		62	1.6	12
26.1	67	0.75	1086	1.0	0.77	1097	B		60	1.5	09
21.9	80	0.5	821	1.3	0.67	1080	B		57	1.3	10
18.6	94	0.5	880	1.2	0.61	1053	B		52	1.1	11

A Motor Flanges Available
Flange Motore Disponibili

B Supplied with Reduction Bushing
Fornito con Bussola di Riduzione

B Available on Request without reduction bushing
Disponibile a Richiesta senza Bussola di Riduzione

C Motor Flange Holes Position
Posizione Fori Flangia Motore

EN Unit M63 is supplied with synthetic oil, providing "long life" lubrication. For mounting position V5-V6 please contact us. See table 1 for lubrication and recommended quantity. In table 2 please see possible radial loads and axial loads on the gearbox. For complete documentation please visit our web site.

I Il riduttore tipo M63 viene fornito lubrificato a vita con olio sintetico. Per posizioni V5-V6 contattare il ns. servizio tecnico. Vedi tab.1 per oli e quantità consigliati. In tab.2 sono presenti i carichi radiali e assiali applicabili al riduttore. Per la documentazione completa consulta il nostro sito.

E El reductor tamaño M63 se suministra, lubricado de por vida con aceite sintético. Para las posiciones V5 y V6 contactar con nuestro servicio técnico. Ver tabla 1, para cantidades y aceites recomendados. En la tabla 2, se encuentran las cargas radiales y axiales admitidas por el reductor. Para documentación completa, consultar nuestra Web.

LUBRICATION M63 Oil Quantity 10.56 ounces

SHELL Omala S4 WE 320

ENI Telium VSF 320

For all details on lubrication and plugs check our website **tab. 1**
Per maggiori dettagli su lubrificazione e tappi olio vedi il nostro sito web

RADIAL AND AXIAL LOADS

Output shaft

Albero di uscita

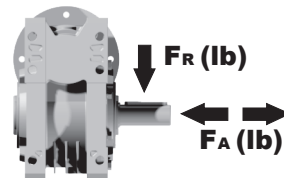

n_2 [min ⁻¹]	FA [lb]	FR [lb]
200	81	404.5
150	90	450
100	103.5	517
75	112.5	562
50	135	674.5
25	157	854
15	180	899

Input shaft

albero in entrata

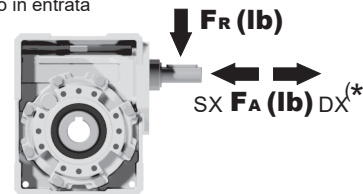

n_1 [min ⁻¹]	FA [lb]	FR [lb]
1750	20	101

***Strong axial loads in the DX direction are not allowed.**
Non sono consentiti forti carichi assiali con direzione DX

tab. 2

PM63FB... Basic wormbox
Riduttore base

Gearbox weight
peso riduttore **13.23 lb**

M. flanges	Kit code	øF	A
56C	KU063.4.041	6.50	4.449
143/5 TC	KU063.4.041	6.50	4.449

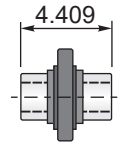
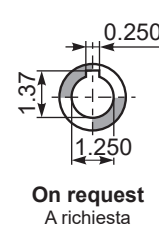
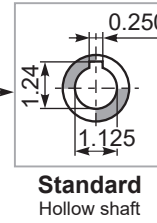
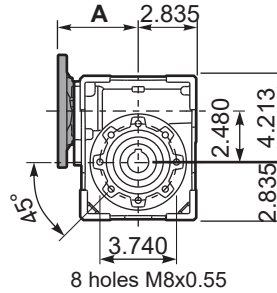
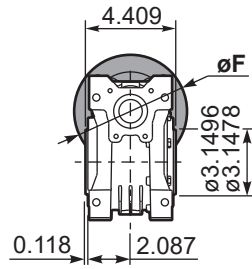

PM63FC... Square flange
Flangia quadrata

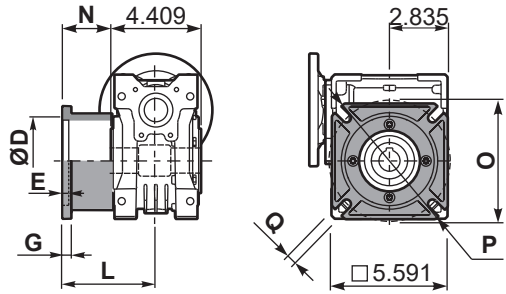

PM63F1... Round flange
Flangia rotonda

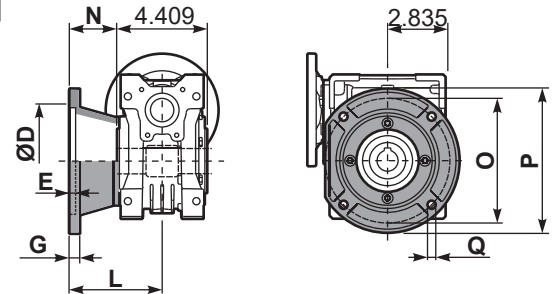

type B	øD	E	G	L	N	O	P	Q	kit code
FC	4.5296 4.5276	0.24	0.39	3.228	1.024	5.906	7.087	0.43	KM63.9.010
FL	4.5296 4.5276	0.24	0.39	4.409	2.205	5.906	7.087	0.43	KM63.9.011

type S	øD	E	G	L	N	O	P	Q	kit code
F1	5.1205 5.1181	0.20	0.39	3.858	1.653	6.496	7.874	0.43	KM63.9.012
F2	5.1205 5.1181	0.20	0.39	4.213	2.008	6.496	7.874	0.43	KM63.9.013
F3	4.3327 4.3307	0.20	0.65	3.169	0.965	5.118	6.299	0.43	KM63.9.014

PM63FB... Feet
Piedini

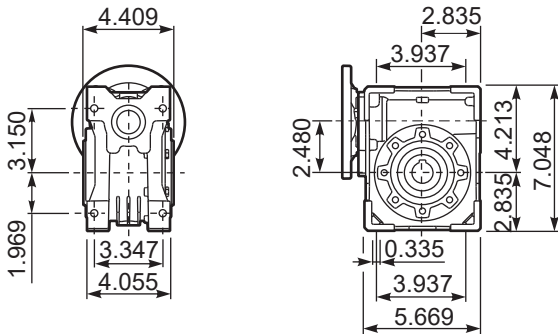

PM63BR... Reaction arm
Braccio di reazione

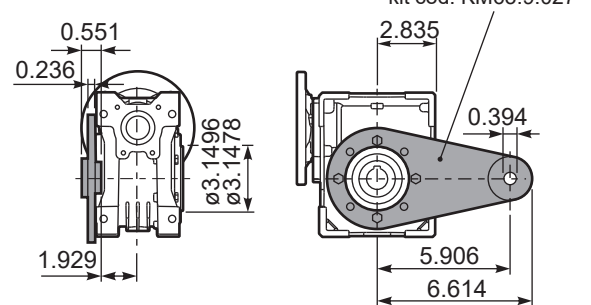

RM63FB... Input shaft
Albero in entrata

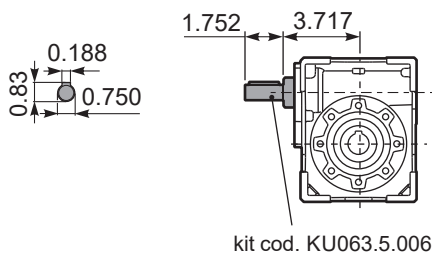



QUICK SELECTION / Selezione veloce

input speed (n_1) = 1750 min⁻¹

Output Speed n_2 [min ⁻¹]	Ratio i	Motor power P_{1M} [HP]	Output torque M_{2M} [lb in]	Service factor f.s.	Nominal power P_{1R} [HP]	Nominal torque M_{2R} [lb in]	Available NEMA motor flanges			Dynamic efficiency RD	Tooth Module [mm]	 Ratios code
							-W	-X	-Y			
							56C	143-5TC	182-4TC			
250.0	7	5	1109	2.2	10.91	2390	B	B		88	4.23	01
175.0	10	5	1441	1.8	9.27	2638	B	B		80	4.2	02
125.0	14	5	1967	1.4	7.30	2832	B	B		78	4.5	03
87.5	20	5	2845	1.0	4.87	2735	B	B		79	3.4	04
79.5	22	3	1854	1.5	4.48	2735	B	B		78	3.1	05
62.5	28	3	2269	1.4	4.32	3222	B	B		75	4.7	06
46.1	38	3	2915	1.1	3.26	3124	B	B		71	3.5	07
38.0	46	2	2253	1.3	2.72	3027	B	B		68	3.1	08
33.7	52	2	2472	1.1	2.20	2682	B	B		66	2.7	09
26.1	67	1.5	2353	1.1	1.73	2682	B	B		65	2.1	10
23.6	74	1.5	2319	1.1	1.63	2487	B	B		58	1.9	11
18.2	96	1	1833	1.2	1.24	2248	B	B		53	1.5	12

A Motor Flanges Available
Flange Motore Disponibili

B Supplied with Reduction Bushing
Fornito con Bussola di Riduzione

B Available on Request without reduction bushing
Disponibile a Richiesta senza Bussola di Riduzione

C Motor Flange Holes Position
Posizione Fori Flangia Motore

EN Unit M85 is supplied with synthetic oil, providing "long life" lubrication. For mounting position V5-V6 please contact us.
See table 1 for lubrication and recommended quantity. In table 2 please see possible radial loads and axial loads on the gearbox.
For complete documentation please visit our web site.

I Il riduttore tipo M85 viene fornito lubrificato a vita con olio sintetico. Per posizioni V5-V6 contattare il ns. servizio tecnico.
Vedi tab.1 per oli e quantità consigliati. In tab.2 sono presenti i carichi radiali e assiali applicabili al riduttore.
Per la documentazione completa consulta il nostro sito.

E El reductor tamaño M85 se suministra, lubricado de por vida con aceite sintético. Para las posiciones V5 y V6 contactar con nuestro servicio técnico.
Ver tabla 1, para cantidades y aceites recomendados. En la tabla 2, se encuentran las cargas radiales y axiales admitidas por el reductor.
Para documentación completa, consultar nuestra Web.

LUBRICATION M85 Oil Quantity 42.23 ounces

SHELL Omala S4 WE 320

ENI Telium VSF 320

For all details on lubrication and plugs check our website **tab. 1**
Per maggiori dettagli su lubrificazione e tappi olio vedi il nostro sito web

RADIAL AND AXIAL LOADS

Output shaft

Albero di uscita

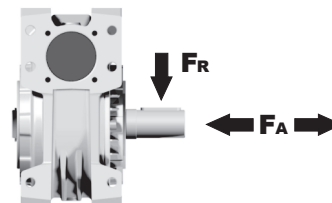

n_2 [min ⁻¹]	FA [lb]	FR [lb]
200	112	562
150	130	652
100	135	674
75	157	787
50	180	899
25	225	1124
15	261	1304

Input shaft

albero in entrata

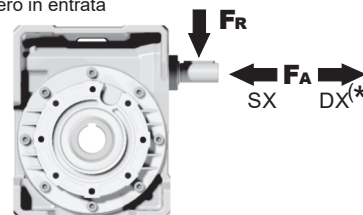

n_1 [min ⁻¹]	FA [lb]	FR [lb]
1750	29	146

***Strong axial loads in the DX direction are not allowed.**
Non sono consentiti forti carichi assiali con direzione DX

tab. 2

PM85FB... Basic wormbox
Riduttore base

Gearbox weight
peso riduttore **41.23 lb**

M. flanges	Kit code	øF	A
56C	KU085.4.041	6.50	4.823
143/5 TC	KU085.4.041	6.50	4.823
182/4 TC	KU085.4.042	8.88	5.528

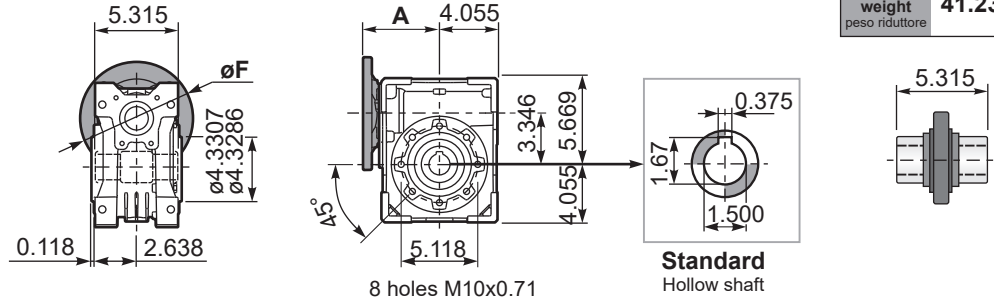

PM85FC... Output flange
Flangia uscita

PM85F1... Output flange
Flangia uscita

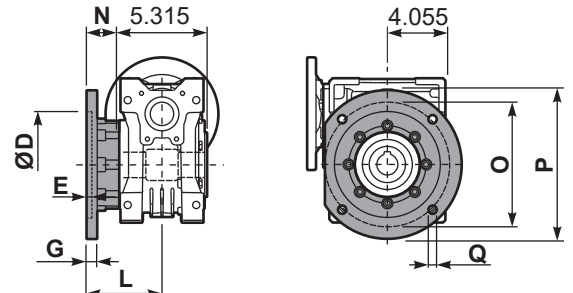
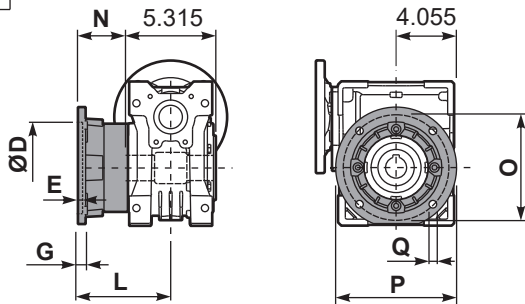

type B	øD	E	G	L	N	O	P	Q	kit code
FC	5.9867 5.9843	0.20	0.63	4.370	1.713	6.929	8.071	0.51	K085.9.010
FL	7.0891 7.0866	0.24	0.71	4.803	2.146	8.465	9.843	0.55	KM85.9.011

type S	øD	E	G	L	N	O	P	Q	kit code
F1	5.1200 5.1181	0.20	0.51	4.311	1.654	6.496	7.874	0.51	KS085.9.015
F2	5.9867 5.9843	0.20	0.63	5.965	3.307	6.929	8.071	0.51	K085.9.010 K085.0.201

PM85FB... Feet
Piedini

PM85BR... Reaction arm
Braccio di reazione

kit cod. K085.9.027

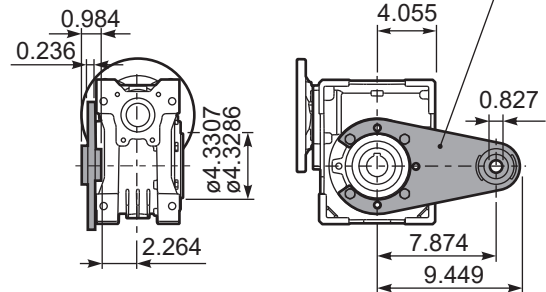
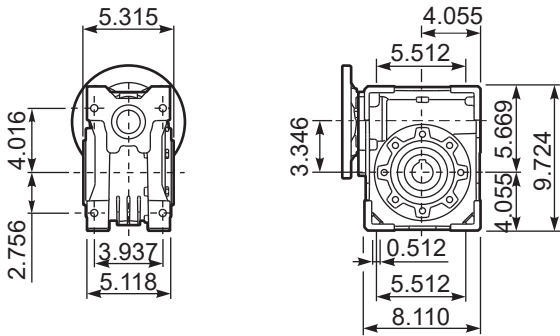

RM85FB... Input shaft
Albero in entrata

PM85.....S... Single Shaft
Albero lento semplice

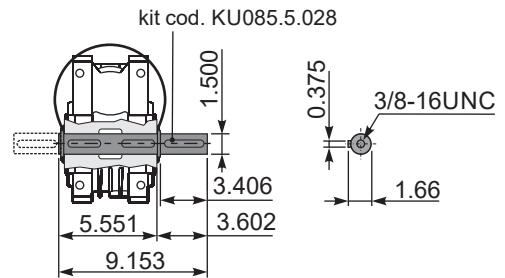
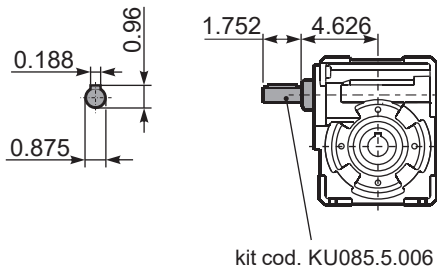

HYDROMECS SPA IS THE LEGAL RESPONSABLE FOR WARRANTY ISSUES.

PLEASE READ CAREFULLY

The following WARNING and CAUTION information are supplied to you for the proper functioning of your product.

Read ALL instructions prior to operating reducer.

Injury to personnel or reducer failure may be caused by improper installation, maintenance or operation.

WARNING:

- **Written authorization is required to operate or use reducers in man lift or people moving devices.**
 - Check to make sure that certain applications do not exceed the allowable load capacities published in the current catalog.
 - Buyer shall be solely responsible for determining the adequacy of the product for any and all uses to which Buyer shall apply the product. The application by Buyer shall not be subject to any implied warranty of fitness for a particular purpose.
 - For safety, Buyer or User should provide protective guards over all shaft extensions and any moving apparatus mounted thereon. The User is responsible for checking all applicable safety codes in his area and providing suitable guards. Failure to do so may result in bodily injury and/or damage to equipment.
 - Gearboxes operating in high position should have a protective shield for any possible parts falling down for casual accidents where people are moving under them.
 - Hot oil and reducers can cause severe burns. Use extreme care when removing lubrication plugs and vents.
 - Make certain that the power supply is disconnected before attempting to service or remove any components. Lock out the power supply and tag it to prevent unexpected application power.
 - Reducers are not to be considered fail safe or self-locking devices. If these features are required, a properly sized, independent holding device should be utilized.
- Reducers should not be used as a brake.
- Any brakes that are used in conjunction with a reducer must be sized or positioned in such a way so as to not subject the reducer to loads beyond the catalog rating.
 - Lifting supports including eyebolts are to be used for vertically lifting the gearbox only and not other associated attachments or motors.
 - Use of an oil with an EP additive on units with backstops may prevent proper operation of the backstop. Injury to personnel, damage to the reducer or other equipment may result.
 - Overhung loads subject shaft bearings and shafts to stress which may cause premature bearing failure and or shaft breakage from bending fatigue, it not sized properly.

SELLING CONDITIONS

Warranty for manufacturing defects will expire one-year after the invoicing date. Hydro-Mec s.p.a. will replace or repair defective parts but will not accept any further changes for direct or indirect damages of any kind. The warranty will become null and void if repairs or changes are carried out without our prior written authorization.

Our company will not be responsible for any direct or indirect damages, caused by a wrong use of the products or for not observing the catalogue/web indication.

If the process requires total protections the customers should consider additional measures to avoid any contaminations arising from the gearboxes. All rights reserved.

All information shown in this catalogue are purely indicative;

Hydro-Mec s.p.a reserves the right to make any necessary variation without prior notice.

HYDROMECS SPA È LEGALMENTE IL RESPONSABILE DEI PROBLEMI DI GARANZIA.

LEGGERE ATTENTAMENTE

Le seguenti raccomandazioni sono fondamentali per un buon funzionamento del vostro prodotto.

Leggere attentamente tutte le istruzioni prima di azionare il riduttore.

L'inappropriata installazione, manutenzione o funzionamento del riduttore può causare incidenti al personale addetto edanni al riduttore stesso.

ATTENZIONE:

- **E' richiesta autorizzazione scritta per azionare riduttori in ascensori o dispositivi per il movimento delle persone.**
- Controllare che alcune applicazioni non eccedano la massima capacità di carico ammessa pubblicata in questo catalogo.
- L'acquirente è l'unico responsabile per la determinazione dell'adeguatezza del prodotto per qualcuna o tutte le utilizzazioni che l'acquirente stesso farà del riduttore. L'applicazione dell'acquirente non potrà essere soggetta ad alcuna implicita garanzia di montaggio per uno scopo particolare.
- Per ragioni di sicurezza l'acquirente dovrà provvedere a porre protezioni adeguate su tutta la lunghezza dell'albero a tutti gli organi in movimento. L'utilizzatore è responsabile del controllo di tutti i codici di sicurezza e la predisposizione di protezioni adeguate. In assenza di tali precauzioni si possono verificare incidenti alle persone e danni agli apparati.
- Su riduttori installati in posizioni elevate utilizzare protezioni adeguate per qualsiasi distacco accidentale di parti nel caso di passaggio di persone al di sotto.
- Olio e riduttori bollenti possono causare gravi ustioni. Usare estrema cautela nella rimozione dei tappi e delle ventole.
- Assicurarsi che la corrente di alimentazione sia scollegata prima di riparare o rimuovere alcun componente. Chiudere l'alimentazione e contrassegnare tale operazione per evitare accensioni accidentali.
- I riduttori non devono essere considerati esenti da guasti o a bloccaggio automatico. Se sono indispensabili queste caratteristiche, deve essere utilizzato un dispositivo indipendente della dimensione adatta. I riduttori non devono essere utilizzati come freni.
- Qualsiasi freno sia utilizzato insieme al riduttore deve essere della giusta grandezza e posizionato in modo da non causare carichi eccessivi non previsti dai dati forniti nel catalogo.
- I dispositivi di sollevamento come le golfare devono essere usati solo per sollevare verticalmente il riduttore e non altri dispositivi associati o motori.
- L'utilizzo di un olio con un additivo EP su gruppi provvisti di dispositivo di arresto possono inficiare l'uso corretto del freno e provocare danni alle persone, alle cose ed al riduttore stesso nonché ad altri apparecchi.
- I Carichi sospesi assoggettano i cuscinetti della vite e la vite stessa a sollecitazioni che possono causare, se non adeguatamente dimensionati, l'usura prematura dei cuscinetti e/o l'arottura della vite a causa della resistenza alla flessione.

CONDIZIONI DI VENDITA

La garanzia relativa a difetti di costruzione ha la durata di un anno dalla data di fatturazione della merce. Tale garanzia comporta per Hydro-Mec s.p.a. l'onere della sostituzione o riparazione delle parti difettose ma non ammette ulteriori addebiti per eventuali danni diretti o indiretti di qualsiasi natura. La garanzia decade nel caso in cui siano state eseguite riparazioni o apportate modifiche senza nostro consenso scritto.

La nostra ditta non si ritiene responsabile per eventuali danni diretti o indiretti derivanti da un uso improprio dei prodotti e dalla mancata osservanza delle indicazioni riportate a catalogo o web.

Se il processo richiede una protezione totale, i clienti dovrebbero prendere in considerazione misure aggiuntive per evitare qualsiasi contaminazione derivante dai riduttori.

Tutti i diritti sono riservati. Tutte le informazioni riportate nel presente catalogo sono puramente indicative; Hydro-Mec s.p.a si riserva il diritto di apportare qualsiasi variazione necessaria senza preavviso.

HYDRO · MEC

HIGH EFFICIENCY GEARBOXES

Via della Tecnica, 19 - 36049 Sovizzo (VI)
Tel. +39 0444551911 - Fax. +39 0444 536139
hydromec@hydromec.com



Distributed from

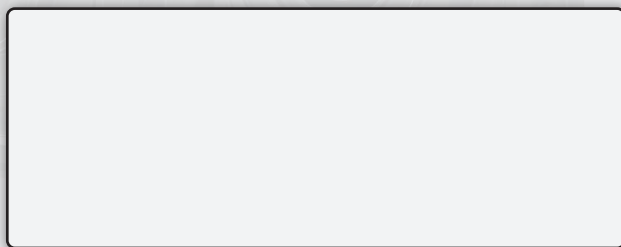

CT - WGI VQM - HM0 2 5 - ML

