

VRT SERIES

The VRT series sets the new standard in applications requiring extremely high torque density and rigidity. Its compact design and robotic industry ISO flange is ideal for equipment requiring high speed, high precision indexing movement and streamlined installation. The remarkable torsional stiffness and ultra low backlash combine to provide outstanding positioning accuracy.

This product comes standard with <3 arc-min backlash, but is also available with reduced options down to <1 arc-min. The VRT is the most robust planetary solution in the marketplace and is used across a numerous range of applications including 7th axis robot shuttles, dial tables, end of arm tooling and any other axis where installation space, reduced assembly time and torque density play an important role.

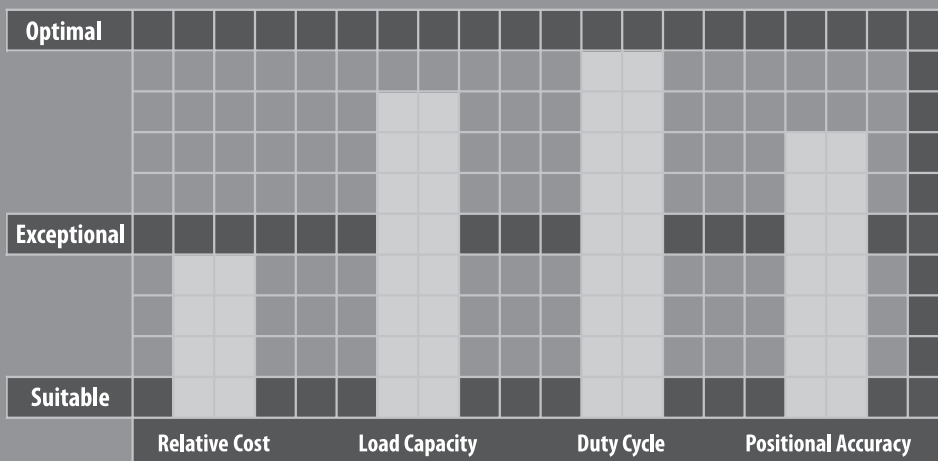

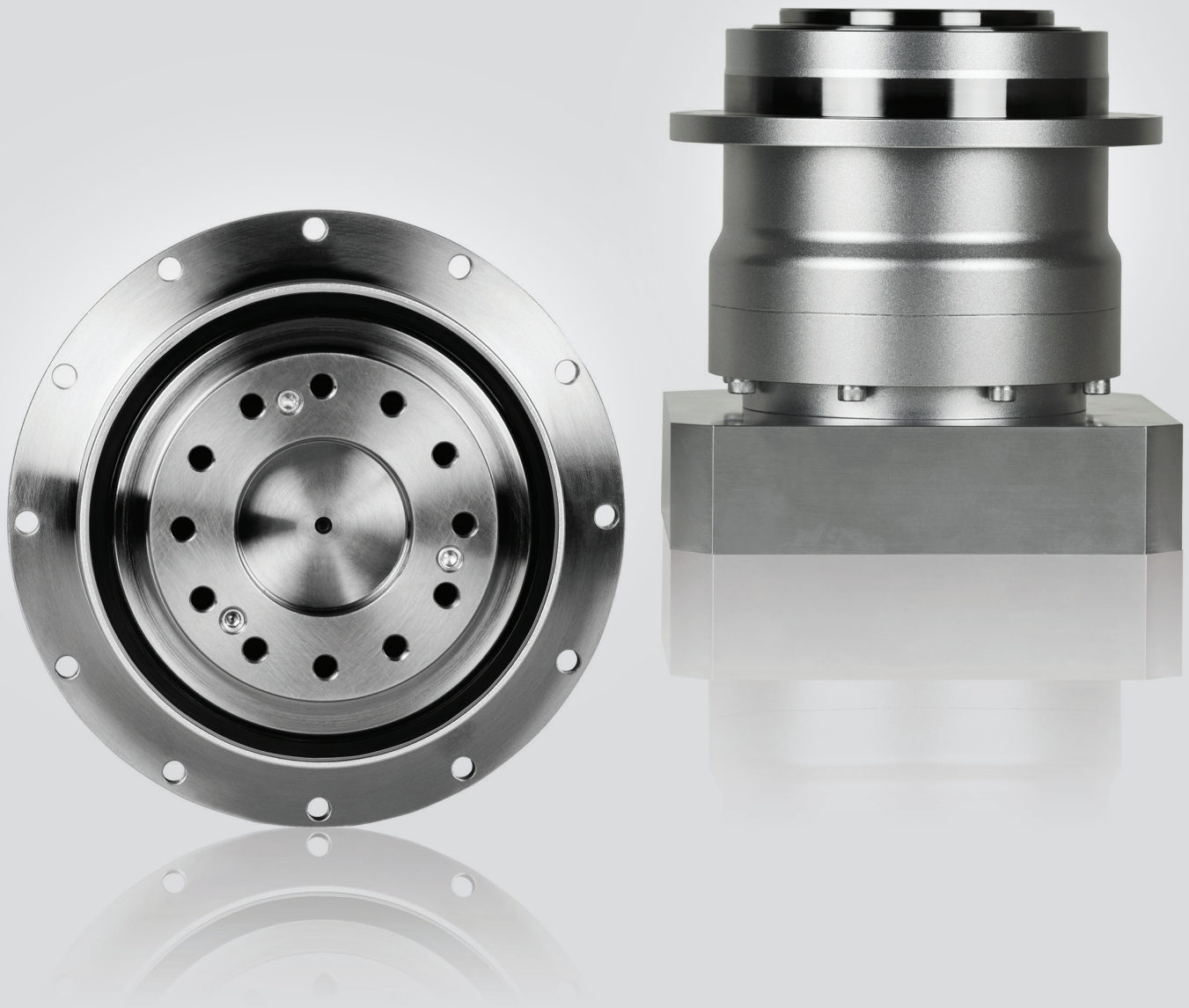

VRT SERIES

- The most compact and robust option for machine builders. Tapered roller bearings allow for high radial and axial loading
- ISO robotic mounting interface for superior flexibility and direct mounting of pinions, pulleys and turntables
- Exceptional torsional rigidity for high positional accuracy needs
- Best-In-class standard backlash (≤ 3 arc-min) with reduced backlash options available
- Broad range of mounting adapters offer a simple, precise attachment to any motor
- Maintenance-free solution that is lubricated for life. High performance grease allows flexible mounting in any orientation

VRT SERIES Inline Planetary

VRT Series Features

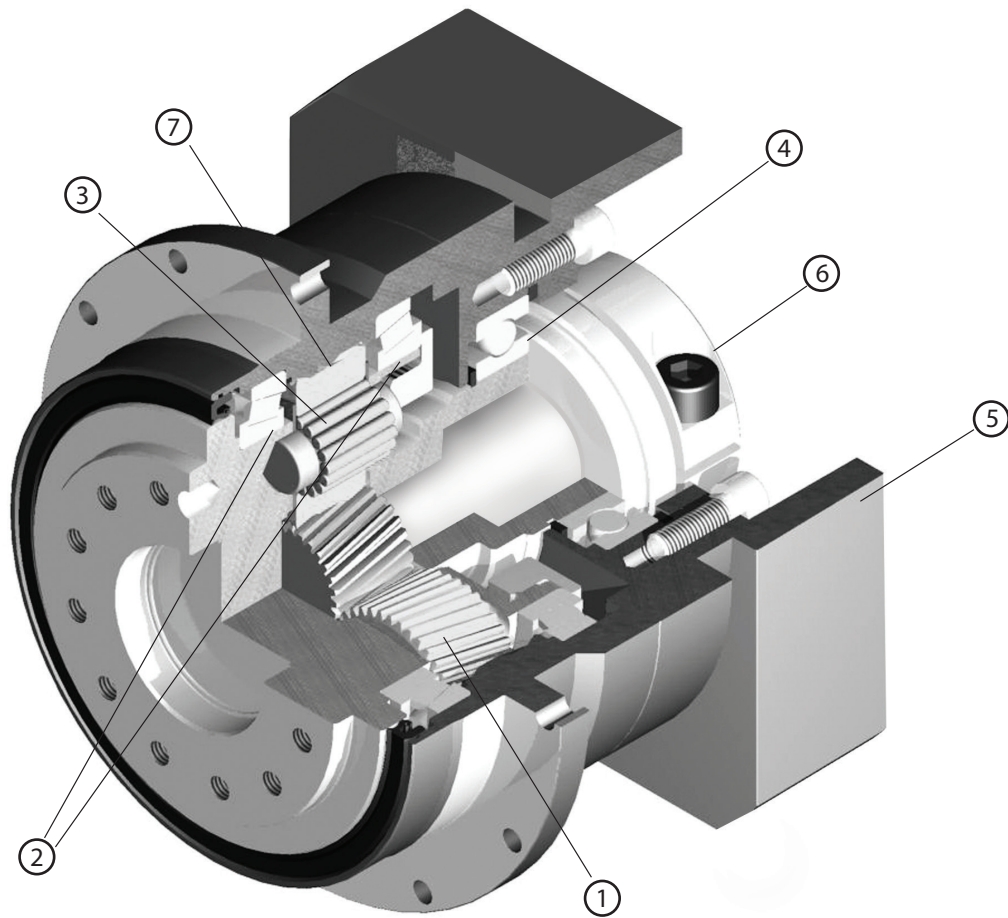

- ① Carburized helical gears with proprietary secondary finishing process for higher accuracy and smooth, quiet operation
- ② One piece output shaft and planet carrier with two robust tapered bearings straddling the planet gears. Higher radial/axial load capacity, stiffness, torque density and safety factor, with guaranteed alignment of gearing
- ③ Uncaged needle roller bearings provide excellent torque density and torsional rigidity
- ④ Unique labyrinth input seal design greatly reduces heat and increases system efficiency. IP65 protection is available for wash down applications
- ⑤ Optimized mounting system with active centering on motor pilot diameter guarantees alignment of motor. Motor can be installed in any orientation
- ⑥ True concentric motor shaft clamping connection, optimized for your specific motor. Reduced inertia for dynamic performance and balanced for high speed operation
- ⑦ Ring gear machined directly into the housing, not welded or pressed in. Provides greater concentricity and elimination of speed fluctuation

VRT Series Model Code

VRT - 110 C - 7 - F 3 - 19HB16

Series

Design version

Frame size: 047, 064, 090, 110, 140, 200, 255, 285

Output mounting style: F: Flange

Ratio:
1-Stage: 4, 5, 7, 10
2-Stage: 16, 20, 25, 28, 35, 40, 50, 70, 100

Standard Backlash: ≤ 3 arc-min
Reduced Backlash: ≤ 1 arc-min (*2)

Motor mounting code (*1)

- *1) Motor mounting code varies depending on the motor. Use the selection tool link below to configure the code.
- *2) Sizes 090/110/140/200 Only

Contact us for additional information or refer to our online gearbox selection tool.
Selection tool <https://www.nidec-drivetechnology.co.jp/selection/all/>



VRT

VRT SERIES Inline Planetary

VRT 047 1-Stage Specifications

Frame Size	047										
Ratio	Unit	Notes	4	5	6	7	8	9	10		
Nominal Output Torque	[Nm]	*1	9	10	10	10	10	10	10		
Maximum Acceleration Torque	[Nm]	*2	21	21	21	21	21	14	14		
Maximum Torque	[Nm]	*3	25	25	25	25	25	17	17		
Emergency Stop Torque	[Nm]	*4	35	35	35	35	35	30	30		
Nominal Input Speed	[rpm]	*5	4000	4000	4000	4000	4000	4000	4000		
Maximum Input Speed	[rpm]	*6	8000	8000	8000	8000	8000	8000	8000		
No Load Running Torque	[Nm]	*7	0.03								
Maximum Radial Load	[N]	*8	1100								
Maximum Axial Load	[N]	*9	550								
Maximum Tilting Moment	[Nm]	*10	32								
Moment of Inertia ($\leq \varnothing 8$)	[kgcm ²]	--	0.052	0.043	0.038	0.036	0.034	0.033	0.032		
Moment of Inertia ($\leq \varnothing 14$)	[kgcm ²]	--	0.17	0.16	0.15	0.15	0.15	0.15	0.15		
Efficiency	[%]	*11	95								
Torsional Rigidity	[Nm/arc-min]	*12	2								
Maximum Torsional Backlash	[arc-min]	--	≤ 3								
Noise Level	dB [A]	*13	≤ 61								
Protection Class	--	*14	IP54 (IP65)								
Ambient Temperature	[°C]	--	0 - 40								
Permitted Housing Temperature	[°C]	--	90								
Weight	[kg]	*15	0.7								

VRT 047 2-Stage Specifications

Frame Size	047										
Ratio	Unit	Notes	16	20	25	28	35	40	45		
Nominal Output Torque	[Nm]	*1	14	14	15	15	15	15	11		
Maximum Acceleration Torque	[Nm]	*2	21	21	21	21	21	21	14		
Maximum Torque	[Nm]	*3	21	21	21	21	21	21	14		
Emergency Stop Torque	[Nm]	*4	35	35	35	35	35	35	30		
Nominal Input Speed	[rpm]	*5	4000	4000	4000	4000	4000	4000	4000		
Maximum Input Speed	[rpm]	*6	8500	8500	8500	8500	8500	8500	8500		
No Load Running Torque	[Nm]	*7	0.01								
Maximum Radial Load	[N]	*8	1100								
Maximum Axial Load	[N]	*9	550								
Maximum Tilting Moment	[Nm]	*10	32								
Moment of Inertia ($\leq \varnothing 8$)	[kgcm ²]	--	0.039	0.035	0.034	0.038	0.034	0.030	0.034		
Moment of Inertia ($\leq \varnothing 14$)	[kgcm ²]	--	--	--	--	--	--	--	--		
Efficiency	[%]	*11	90								
Torsional Rigidity	[Nm/arc-min]	*12	2								
Maximum Torsional Backlash	[arc-min]	--	≤ 5								
Noise Level	dB [A]	*13	≤ 61								
Protection Class	--	*14	IP54 (IP65)								
Ambient Temperature	[°C]	--	0 - 40								
Permitted Housing Temperature	[°C]	--	90								
Weight	[kg]	*15	0.8								

VRT 047 2-Stage Specifications

Frame Size	047							
Ratio	Unit	Notes	50	60	70	80	90	100
Nominal Output Torque	[Nm]	*1	15	15	15	15	11	11
Maximum Acceleration Torque	[Nm]	*2	21	21	21	21	14	14
Maximum Torque	[Nm]	*3	21	21	21	21	14	14
Emergency Stop Torque	[Nm]	*4	35	35	35	35	30	30
Nominal Input Speed	[rpm]	*5	4000	4000	4000	4000	4000	4000
Maximum Input Speed	[rpm]	*6	8500	8500	8500	8500	8500	8500
No Load Running Torque	[Nm]	*7	0.01					
Maximum Radial Load	[N]	*8	1100					
Maximum Axial Load	[N]	*9	550					
Maximum Tilting Moment	[Nm]	*10	32					
Moment of Inertia ($\leq \varnothing 8$)	[kgcm ²]	--	0.030	0.030	0.030	0.030	0.030	0.030
Moment of Inertia ($\leq \varnothing 14$)	[kgcm ²]	--	--	--	--	--	--	--
Efficiency	[%]	*11	90					
Torsional Rigidity	[Nm/arc-min]	*12	2					
Maximum Torsional Backlash	[arc-min]	--	≤ 5					
Noise Level	dB [A]	*13	≤ 61					
Protection Class	--	*14	IP54 (IP65)					
Ambient Temperature	[°C]	--	0 - 40					
Permitted Housing Temperature	[°C]	--	90					
Weight	[kg]	*15	0.8					

- *1) At nominal input speed, service life is 20,000 hours
- *2) The maximum torque when starting or stopping operation. Apply Cycle Factor f_0 , found on page 468, for higher duty cycle applications
- *3) Permitted 10,000 times during service life. Based on 10% of maximum radial load and smooth output shaft
- *4) The maximum torque allowed under a stress situation. Permitted 1,000 times during service life
- *5) The average input speed at nominal input torque. Maintain housing temperature below permitted value
- *6) The maximum intermittent input speed
- *7) Torque at no load applied to the input shaft at nominal input speed
- *8) The maximum radial load that the gearbox can accept
- *9) The maximum axial load that the gearbox can accept
- *10) The maximum load at output flange surface
- *11) The efficiency at the nominal output torque rating
- *12) This does not include lost motion
- *13) Contact Nidec Drive Technology for the testing conditions and environment
- *14) IP65 (wash-down) is available as an option. Contact Nidec Drive Technology for more details
- *15) Weight may vary slightly between models

VRT SERIES Inline Planetary

VRT 047 1-Stage Dimensions

Input bore size $\leq \varnothing 8$ mm

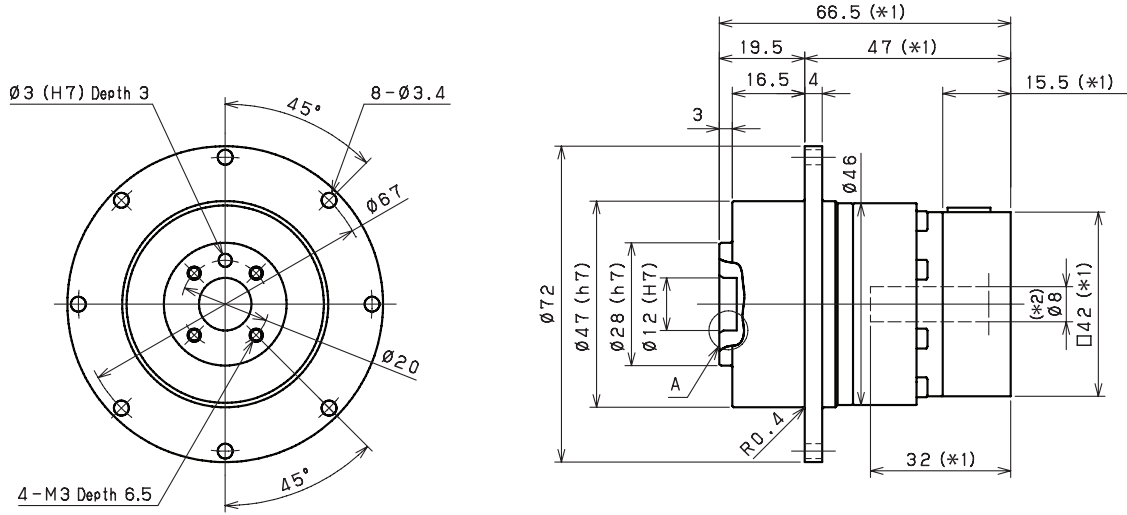

Input bore size $\leq \varnothing 14$ mm

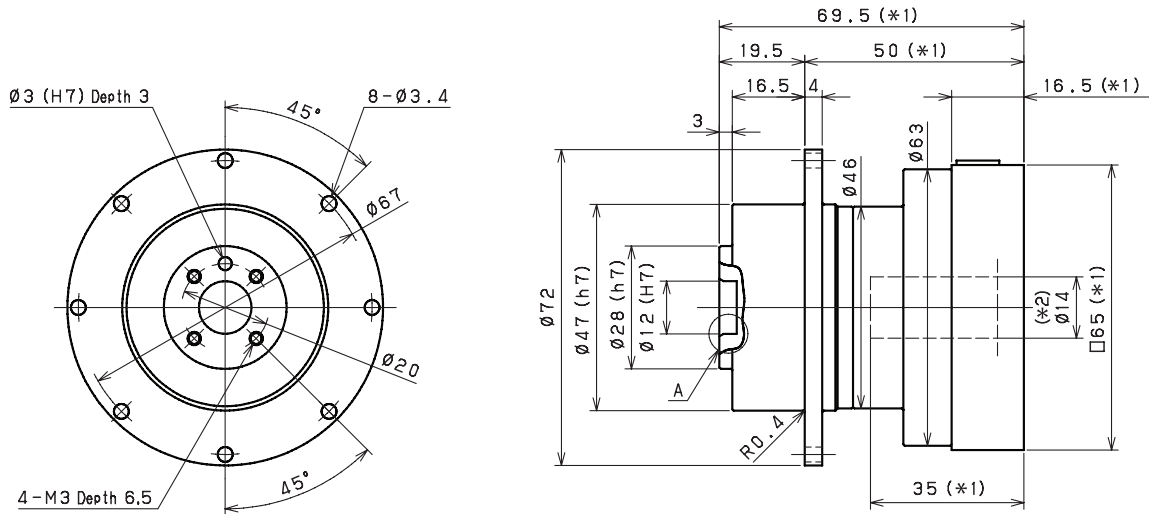

*1) Length will vary depending on motor

*2) Bushing will be inserted to adapt to motor shaft

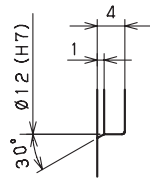

Enlarged detail A

VRT 047 2-Stage Dimensions

Input bore size $\cong \varnothing 8 \text{ mm}$

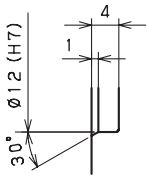
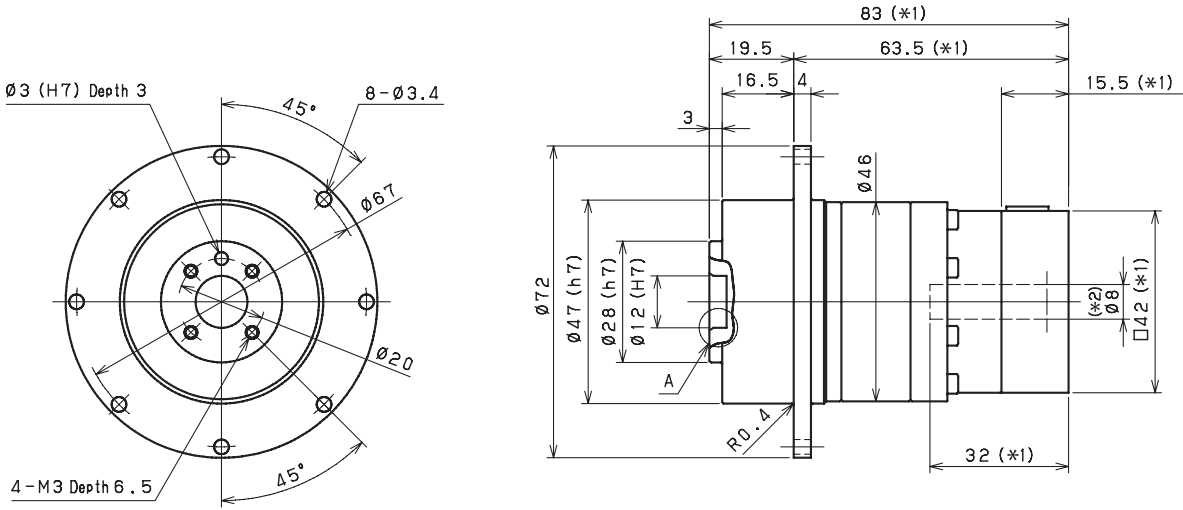

Enlarged detail A

- *1) Length will vary depending on motor
- *2) Bushing will be inserted to adapt to motor shaft

VRT

VRT o64 1-Stage Specifications

Frame Size	064										
Ratio	Unit	Note	4	5	6	7	8	9	10		
Nominal Output Torque	[Nm]	*1	27	28	28	28	28	28	28		
Maximum Acceleration Torque	[Nm]	*2	66	66	66	66	66	46	46		
Maximum Torque	[Nm]	*3	79	79	79	79	76	55	55		
Emergency Stop Torque	[Nm]	*4	100	100	100	100	100	80	80		
Nominal Input Speed	[rpm]	*5	3300	4000	4000	4000	4000	4000	4000		
Maximum Input Speed	[rpm]	*6	7500	7500	7500	7500	7500	7500	7500		
No Load Running Torque	[Nm]	*7	0.08								
Maximum Radial Load	[N]	*8	1500								
Maximum Axial Load	[N]	*9	750								
Maximum Tilting Moment	[Nm]	*10	58								
Moment of Inertia ($\leq \varnothing 8$)	[kgcm ²]	-	0.13	0.10	0.085	0.075	0.068	0.064	0.062		
Moment of Inertia ($\leq \varnothing 14$)	[kgcm ²]	--	0.24	0.21	0.20	0.19	0.18	0.18	0.17		
Moment of Inertia ($\leq \varnothing 19$)	[kgcm ²]	--	0.52	0.49	0.47	0.46	0.46	0.45	0.45		
Efficiency	[%]	*11	95								
Torsional Rigidity	[Nm/arc-min]	*12	12	12	11	11	8	8	8		
Maximum Torsional Backlash	[arc-min]	--	≤ 3								
Noise Level	dB [A]	*13	≤ 66								
Protection Class	--	*14	IP54 (IP65)								
Ambient Temperature	[°C]	--	0 - 40								
Permitted Housing Temperature	[°C]	--	90								
Weight	[kg]	*15	1.4								

VRT o64 2-Stage Specifications

Frame Size	064										
Ratio	Unit	Note	16	20	25	28	35	40	45		
Nominal Output Torque	[Nm]	*1	32	32	43	45	45	45	32		
Maximum Acceleration Torque	[Nm]	*2	66	66	66	66	66	66	46		
Maximum Torque	[Nm]	*3	66	66	66	66	66	66	46		
Emergency Stop Torque	[Nm]	*4	100	100	100	100	100	100	80		
Nominal Input Speed	[rpm]	*5	4000	4000	4000	4000	4000	4000	4000		
Maximum Input Speed	[rpm]	*6	8500	8500	8500	8500	8500	8500	8500		
No Load Running Torque	[Nm]	*7	0.04								
Maximum Radial Load	[N]	*8	1500								
Maximum Axial Load	[N]	*9	750								
Maximum Tilting Moment	[Nm]	*10	58								
Moment of Inertia ($\leq \varnothing 8$)	[kgcm ²]	-	0.072	0.064	0.062	0.069	0.061	0.051	0.061		
Moment of Inertia ($\leq \varnothing 14$)	[kgcm ²]	--	0.18	0.18	0.17	0.18	0.17	0.16	0.17		
Moment of Inertia ($\leq \varnothing 19$)	[kgcm ²]	--	0.46	0.45	0.45	0.46	0.45	0.44	0.45		
Efficiency	[%]	*11	90								
Torsional Rigidity	[Nm/arc-min]	*12	12	12	12	12	12	11	11		
Maximum Torsional Backlash	[arc-min]	--	≤ 3								
Noise Level	dB [A]	*13	≤ 66								
Protection Class	--	*14	IP54 (IP65)								
Ambient Temperature	[°C]	--	0 - 40								
Permitted Housing Temperature	[°C]	--	90								
Weight	[kg]	*15	1.6								

VRT 064 2-Stage Specifications

Frame Size	064								
Ratio	Unit	Note	50	60	70	80	90	100	
Nominal Output Torque	[Nm]	*1	45	45	45	45	32	32	
Maximum Acceleration Torque	[Nm]	*2	66	66	66	66	46	46	
Maximum Torque	[Nm]	*3	66	66	66	66	46	46	
Emergency Stop Torque	[Nm]	*4	100	100	100	100	80	80	
Nominal Input Speed	[rpm]	*5	4800	4800	5500	5500	5500	5500	
Maximum Input Speed	[rpm]	*6	8500	8500	8500	8500	8500	8500	
No Load Running Torque	[Nm]	*7	0.04						
Maximum Radial Load	[N]	*8	1500						
Maximum Axial Load	[N]	*9	750						
Maximum Tilting Moment	[Nm]	*10	58						
Moment of Inertia ($\leq \varnothing 8$)	[kgcm ²]	-	0.051	0.051	0.051	0.051	0.051	0.051	
Moment of Inertia ($\leq \varnothing 14$)	[kgcm ²]	--	0.16	0.16	0.16	0.16	0.16	0.16	
Moment of Inertia ($\leq \varnothing 19$)	[kgcm ²]	--	0.44	0.44	0.44	0.44	0.44	0.44	
Efficiency	[%]	*11	90						
Torsional Rigidity	[Nm/arc-min]	*12	12	9	11	7	7	8	
Maximum Torsional Backlash	[arc-min]	--	≤ 3						
Noise Level	dB [A]	*13	≤ 66						
Protection Class	--	*14	IP54 (IP65)						
Ambient Temperature	[°C]	--	0 - 40						
Permitted Housing Temperature	[°C]	--	90						
Weight	[kg]	*15	1.6						

- *1) At nominal input speed, service life is 20,000 hours
- *2) The maximum torque when starting or stopping operation. Apply Cycle Factor f_0 , found on page 468, for higher duty cycle applications
- *3) Permitted 10,000 times during service life. Based on 10% of maximum radial load and smooth output shaft
- *4) The maximum torque allowed under a stress situation. Permitted 1,000 times during service life
- *5) The average input speed at nominal input torque. Maintain housing temperature below permitted value
- *6) The maximum intermittent input speed
- *7) Torque at no load applied to the input shaft at nominal input speed
- *8) The maximum radial load that the gearbox can accept
- *9) The maximum axial load that the gearbox can accept
- *10) The maximum load at output flange surface
- *11) The efficiency at the nominal output torque rating
- *12) This does not include lost motion
- *13) Contact Nidec Drive Technology for the testing conditions and environment
- *14) IP65 (wash-down) is available as an option. Contact Nidec Drive Technology for more details
- *15) Weight may vary slightly between models

VRT SERIES Inline Planetary

VRT o64 1-Stage Dimensions

Input bore size $\leq \varnothing 8$ mm

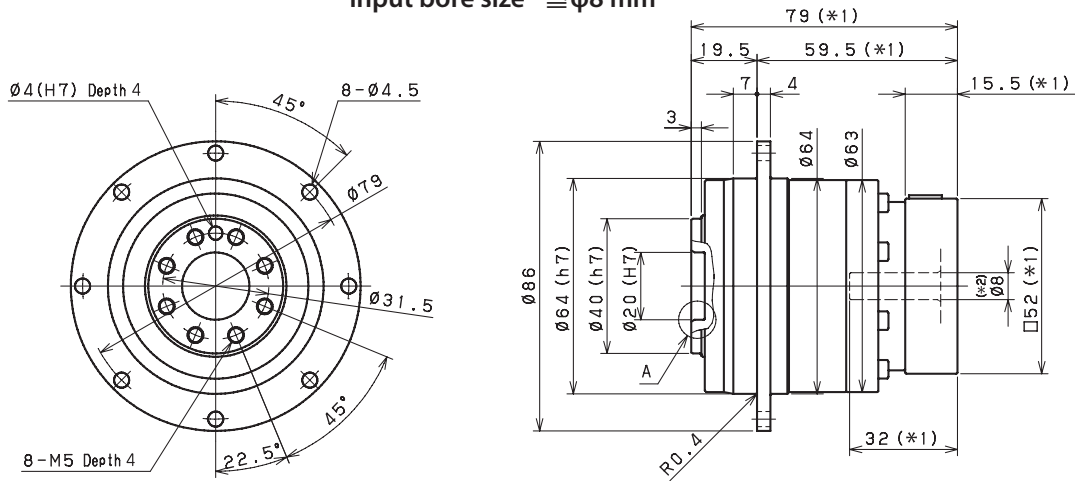

Input bore size $\leq \varnothing 14$ mm

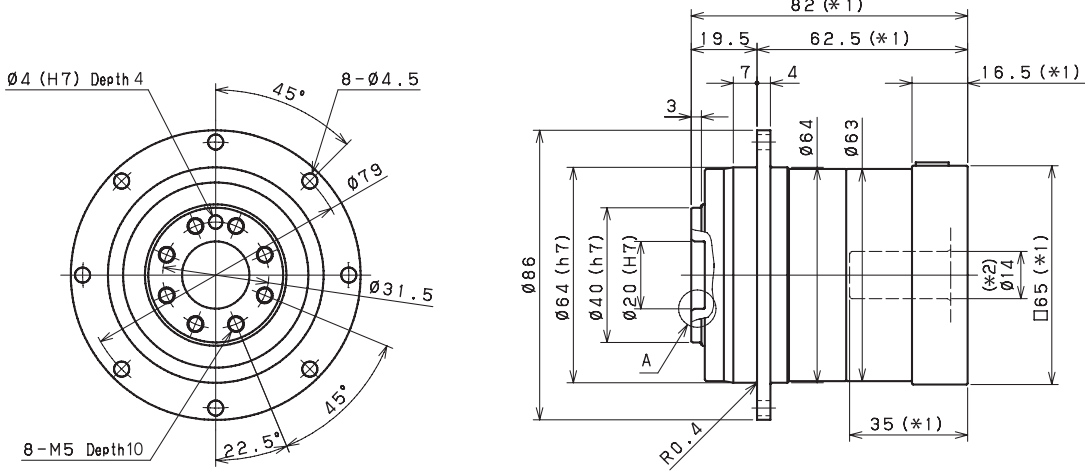

Input bore size $\leq \varnothing 19$ mm

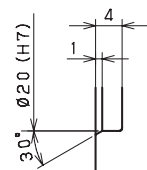
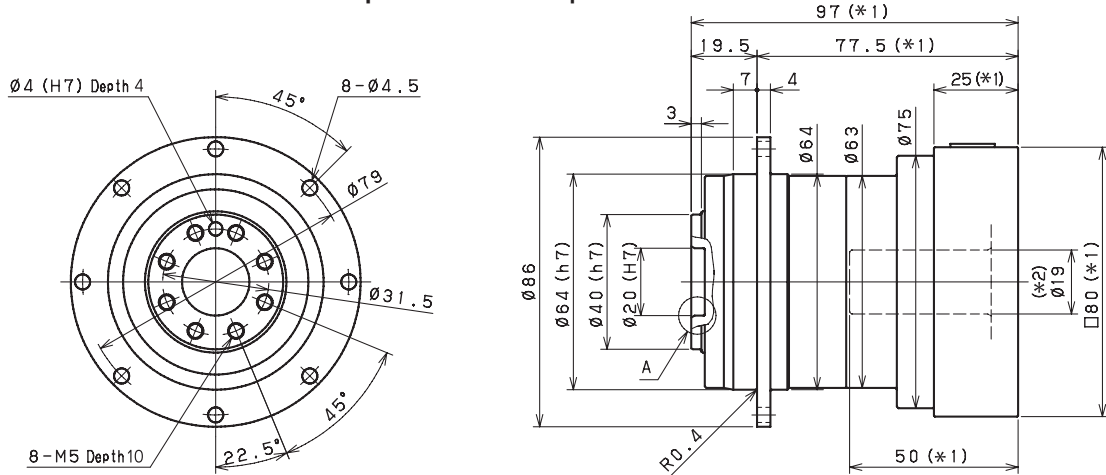

Enlarged detail A

*1) Length will vary depending on motor

*2) Bushing will be inserted to adapt to motor shaft

VRT o64 2-Stage Dimensions

Input bore size $\leq \varnothing 8$ mm

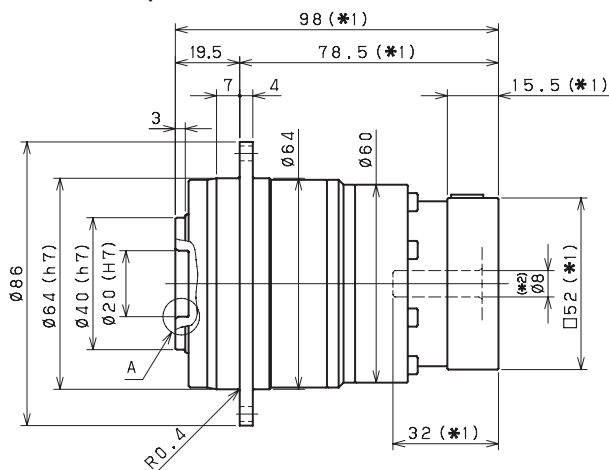
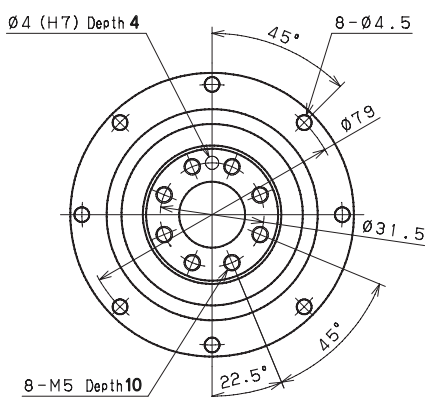

Input bore size $\leq \varnothing 14$ mm

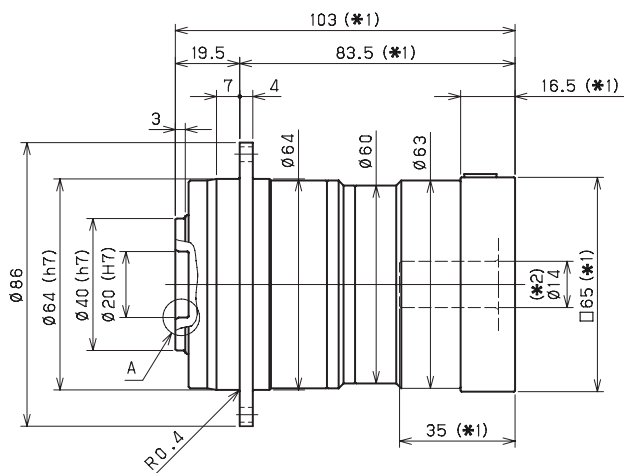
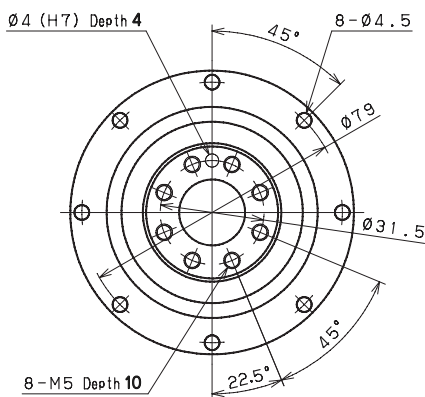

Input bore size $\leq \varnothing 19$ mm

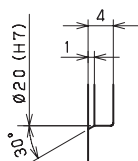
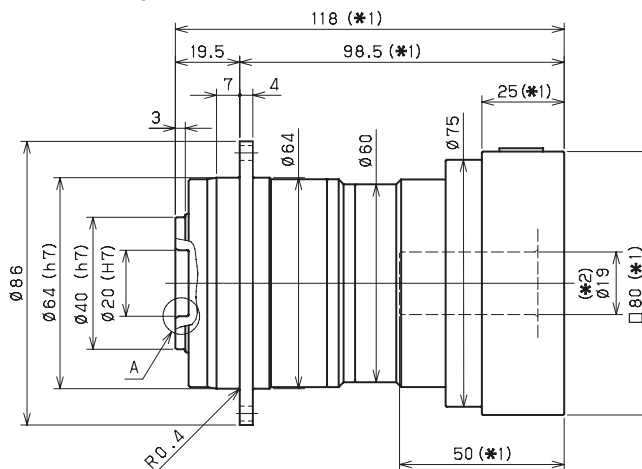
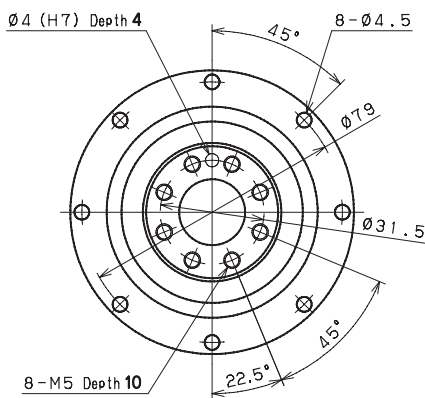

Enlarged detail A

*1) Length will vary depending on motor

*2) Bushing will be inserted to adapt to motor shaft

VRT SERIES Inline Planetary

VRT 090 1-Stage Specifications

Frame Size	090										
Ratio	Unit	Note	4	5	6	7	8	9	10		
Nominal Output Torque	[Nm]	*1	77	84	84	84	84	84	84		
Maximum Acceleration Torque	[Nm]	*2	165	165	165	165	165	112	112		
Maximum Torque	[Nm]	*3	200	200	195	195	190	145	145		
Emergency Stop Torque	[Nm]	*4	250	250	250	250	250	200	200		
Nominal Input Speed	[rpm]	*5	2900	2900	2900	3100	3100	3100	3100		
Maximum Input Speed	[rpm]	*6	7500	7500	7500	7500	7500	7500	7500		
No Load Running Torque	[Nm]	*7	0.17								
Maximum Radial Load	[N]	*8	3300								
Maximum Axial Load	[N]	*9	1700								
Maximum Tilting Moment	[Nm]	*10	170								
Moment of Inertia ($\leq \varnothing 8$)	[kgcm ²]	--	--	--	--	--	--	--	--		
Moment of Inertia ($\leq \varnothing 14$)	[kgcm ²]	--	0.78	0.58	0.48	0.42	0.38	0.36	0.34		
Moment of Inertia ($\leq \varnothing 19$)	[kgcm ²]	--	1.2	0.98	0.87	0.82	0.78	0.75	0.74		
Moment of Inertia ($\leq \varnothing 28$)	[kgcm ²]	--	2.9	2.7	2.6	2.6	2.5	2.5	2.5		
Efficiency	[%]	*11	95								
Torsional Rigidity	[Nm/arc-min]	*12	32	33	30	30	23	23	23		
Maximum Torsional Backlash	[arc-min]	--	Standard ≤ 3 / Reduced ≤ 1								
Noise Level	dB [A]	*13	≤ 67								
Protection Class	--	*14	IP54 (IP65)								
Ambient Temperature	[°C]	--	0 - 40								
Permitted Housing Temperature	[°C]	--	90								
Weight	[kg]	*15	3.6								

VRT 090 2-Stage Specifications

Frame Size	090										
Ratio	Unit	Note	16	20	25	28	35	40	45		
Nominal Output Torque	[Nm]	*1	80	86	106	118	118	118	88		
Maximum Acceleration Torque	[Nm]	*2	165	165	165	165	165	165	112		
Maximum Torque	[Nm]	*3	165	165	165	165	165	165	112		
Emergency Stop Torque	[Nm]	*4	250	250	250	250	250	250	200		
Nominal Input Speed	[rpm]	*5	3500	3500	3500	3500	3500	3500	3500		
Maximum Input Speed	[rpm]	*6	8500	8500	8500	8500	8500	8500	8500		
No Load Running Torque	[Nm]	*7	0.05								
Maximum Radial Load	[N]	*8	3300								
Maximum Axial Load	[N]	*9	1700								
Maximum Tilting Moment	[Nm]	*10	170								
Moment of Inertia ($\leq \varnothing 8$)	[kgcm ²]	--	0.26	0.20	0.19	0.24	0.19	0.12	0.19		
Moment of Inertia ($\leq \varnothing 14$)	[kgcm ²]	--	0.43	0.36	0.36	0.40	0.35	0.28	0.35		
Moment of Inertia ($\leq \varnothing 19$)	[kgcm ²]	--	0.81	0.75	0.74	0.79	0.74	0.67	0.73		
Moment of Inertia ($\leq \varnothing 28$)	[kgcm ²]	--	2.5	2.5	2.5	2.5	2.5	2.4	2.5		
Efficiency	[%]	*11	90								
Torsional Rigidity	[Nm/arc-min]	*12	32	32	32	31	32	30	30		
Maximum Torsional Backlash	[arc-min]	--	Standard ≤ 3 / Reduced ≤ 1								
Noise Level	dB [A]	*13	≤ 67								
Protection Class	--	*14	IP54 (IP65)								
Ambient Temperature	[°C]	--	0 - 40								
Permitted Housing Temperature	[°C]	--	90								
Weight	[kg]	*15	4								

VRT 090 2-Stage Specifications

Frame Size	090							
Ratio	Unit	Note	50	60	70	80	90	100
Nominal Output Torque	[Nm]	*1	118	118	118	118	88	88
Maximum Acceleration Torque	[Nm]	*2	165	165	165	165	112	112
Maximum Torque	[Nm]	*3	165	165	165	165	112	112
Emergency Stop Torque	[Nm]	*4	250	250	250	250	200	200
Nominal Input Speed	[rpm]	*5	3800	3800	4500	4500	4500	4500
Maximum Input Speed	[rpm]	*6	8500	8500	8500	8500	8500	8500
No Load Running Torque	[Nm]	*7	0.05					
Maximum Radial Load	[N]	*8	3300					
Maximum Axial Load	[N]	*9	1700					
Maximum Tilting Moment	[Nm]	*10	170					
Moment of Inertia ($\leq \varnothing 8$)	[kgcm ²]	--	0.12	0.11	0.11	0.11	0.11	0.11
Moment of Inertia ($\leq \varnothing 14$)	[kgcm ²]	--	0.28	0.27	0.27	0.27	0.27	0.27
Moment of Inertia ($\leq \varnothing 19$)	[kgcm ²]	--	0.67	0.67	0.67	0.67	0.67	0.67
Moment of Inertia ($\leq \varnothing 28$)	[kgcm ²]	--	2.4	2.4	2.4	2.4	2.4	2.4
Efficiency	[%]	*11	90					
Torsional Rigidity	[Nm/arc-min]	*12	30	24	28	22	22	22
Maximum Torsional Backlash	[arc-min]	--	Standard ≤ 3 / Reduced ≤ 1					
Noise Level	dB [A]	*13	≤ 67					
Protection Class	--	*14	IP54 (IP65)					
Ambient Temperature	[°C]	--	0 - 40					
Permitted Housing Temperature	[°C]	--	90					
Weight	[kg]	*15	4					

*1) At nominal input speed, service life is 20,000 hours

*2) The maximum torque when starting or stopping operation. Apply Cycle Factor f_0 , found on page 468, for higher duty cycle applications

*3) Permitted 10,000 times during service life. Based on 10% of maximum radial load and smooth output shaft

*4) The maximum torque allowed under a stress situation. Permitted 1,000 times during service life

*5) The average input speed at nominal input torque. Maintain housing temperature below permitted value

*6) The maximum intermittent input speed

*7) Torque at no load applied to the input shaft at nominal input speed

*8) The maximum radial load that the gearbox can accept

*9) The maximum axial load that the gearbox can accept

*10) The maximum load at output flange surface

*11) The efficiency at the nominal output torque rating

*12) This does not include lost motion

*13) Contact Nidec Drive Technology for the testing conditions and environment

*14) IP65 (wash-down) is available as an option. Contact Nidec Drive Technology for more details

*15) Weight may vary slightly between models

VRT SERIES Inline Planetary

VRT 090 1-Stage Dimensions

Input bore size $\cong \varnothing 14$ mm

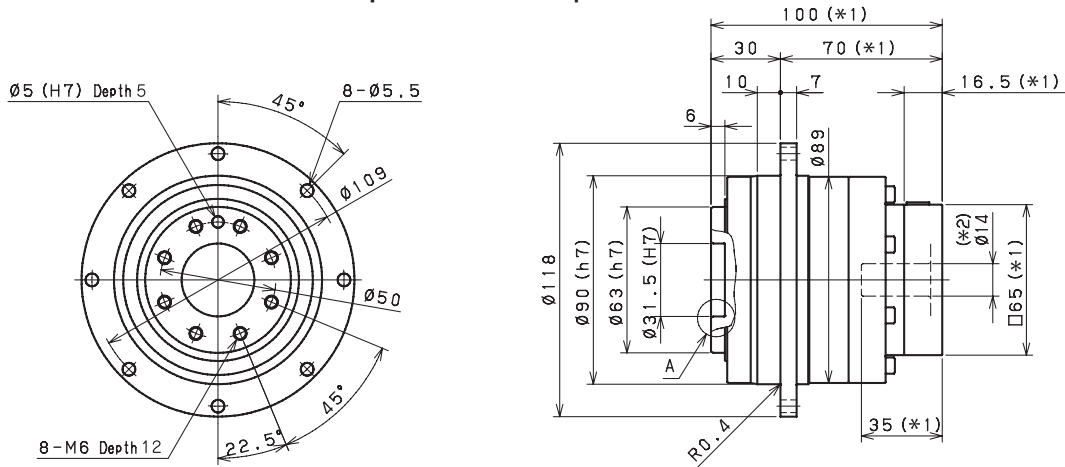

Input bore size $\cong \varnothing 19$ mm

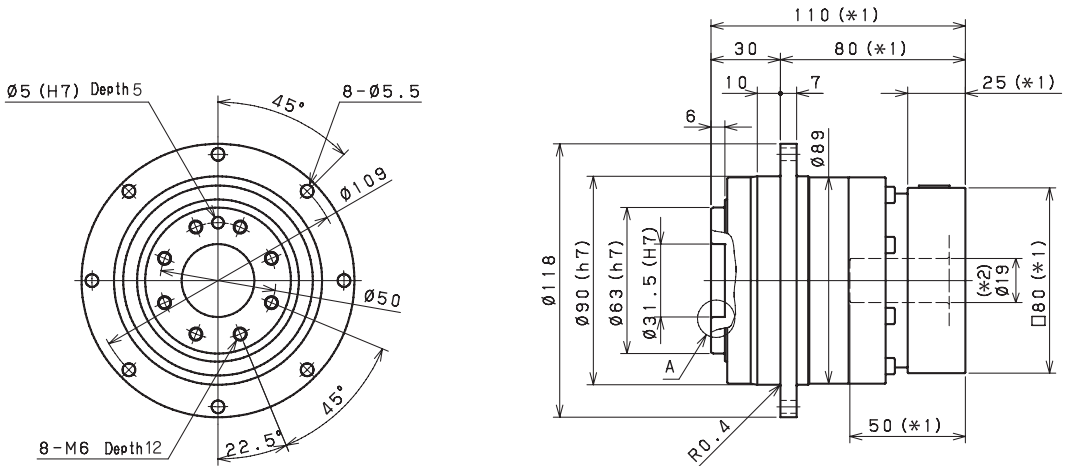

Input bore size $\cong \varnothing 28$ mm

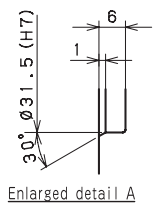
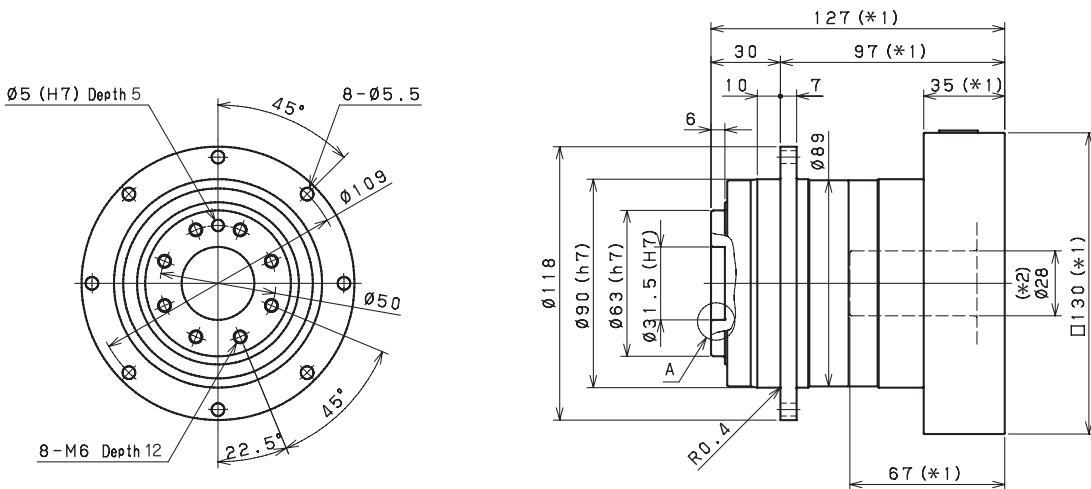

*1) Length will vary depending on motor
*2) Bushing will be inserted to adapt to motor shaft

VRT 090 2-Stage Dimensions

Input bore size $\leq \varnothing 8$ mm

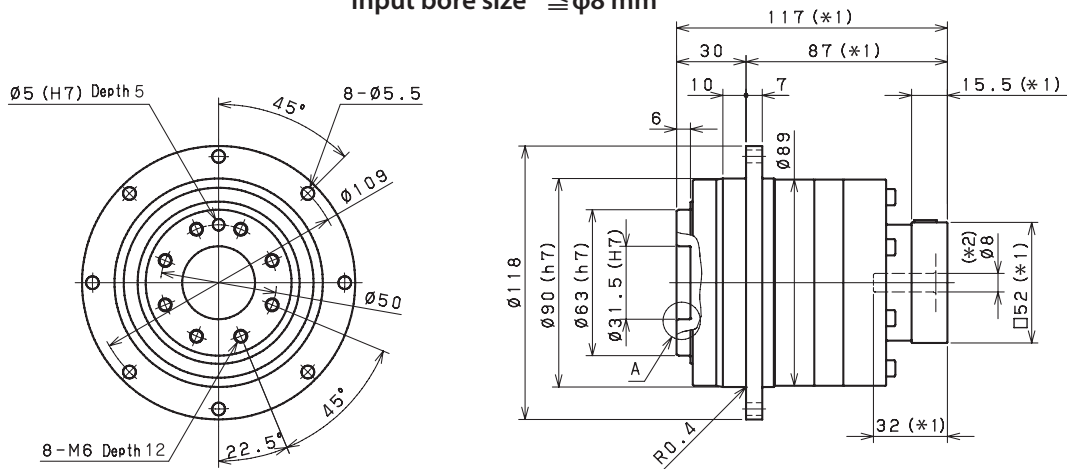

Input bore size $\leq \varnothing 14$ mm

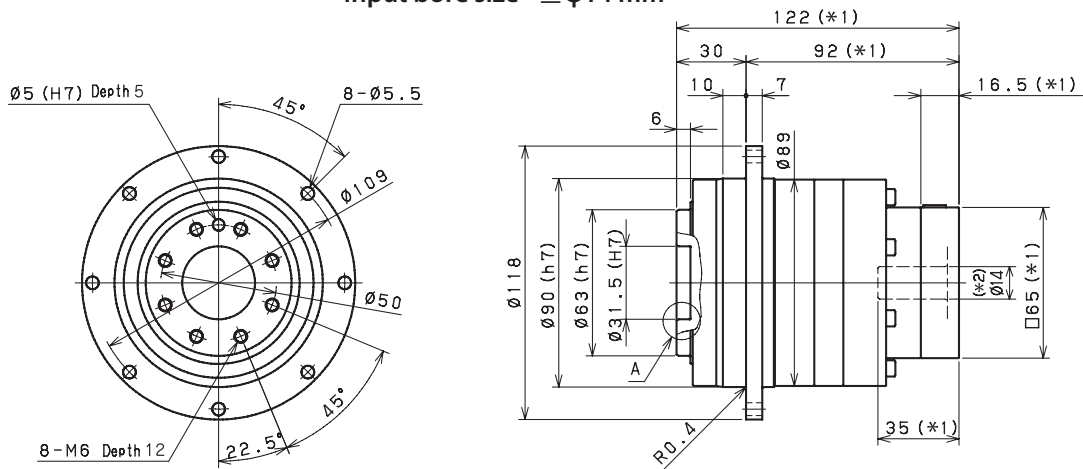

Input bore size $\leq \varnothing 19$ mm^(*3)

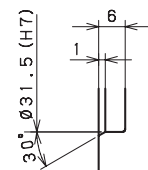
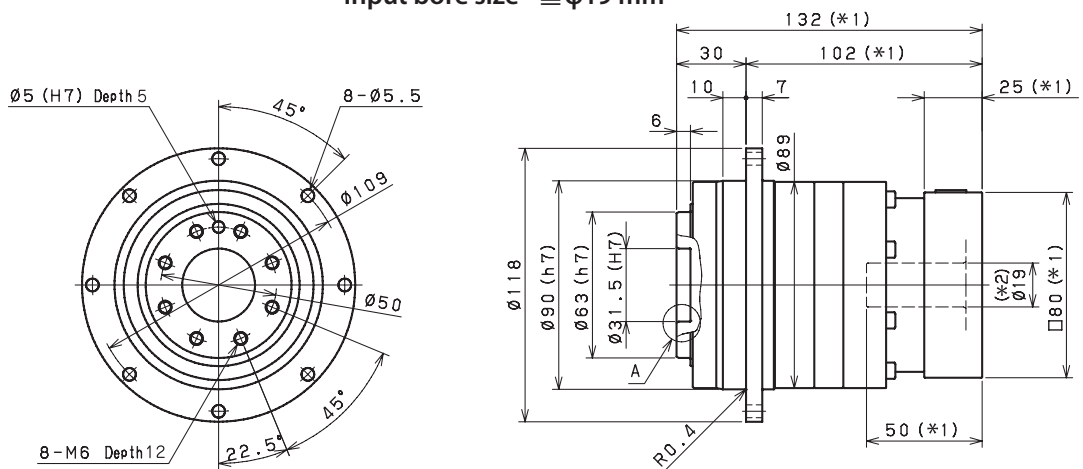

Enlarged detail A

*1) Length will vary depending on motor

*2) Bushing will be inserted to adapt to motor shaft

*3) 28mm input bore is available for this frame size. Use our online configurator to make your selection or contact us for assistance

VRT SERIES Inline Planetary

VRT 110 1-Stage Specifications

Frame Size	110					
Ratio	Unit	Note	4	5	7	10
Nominal Output Torque	[Nm]	*1	146	190	190	190
Maximum Acceleration Torque	[Nm]	*2	390	390	390	292
Maximum Torque	[Nm]	*3	490	490	480	370
Emergency Stop Torque	[Nm]	*4	625	625	625	500
Nominal Input Speed	[rpm]	*5	2800	2800	2800	2800
Maximum Input Speed	[rpm]	*6	5500	5500	5500	5500
No Load Running Torque	[Nm]	*7	0.77			
Maximum Radial Load	[N]	*8	12000			
Maximum Axial Load	[N]	*9	8800			
Maximum Tilting Moment	[Nm]	*10	990			
Moment of Inertia ($\leq \varnothing 8$)	[kgcm ²]	--	--	--	--	--
Moment of Inertia ($\leq \varnothing 14$)	[kgcm ²]	--	--	--	--	--
Moment of Inertia ($\leq \varnothing 19$)	[kgcm ²]	--	3.1	2.1	1.3	0.99
Moment of Inertia ($\leq \varnothing 28$)	[kgcm ²]	--	4.8	3.8	3.1	2.7
Moment of Inertia ($\leq \varnothing 38$)	[kgcm ²]	--	11	10	9.5	9.0
Efficiency	[%]	*11	95			
Torsional Rigidity	[Nm/arcmin]	*12	80	86	76	62
Maximum Torsional Backlash	[Arc-min]	--	Standard ≤ 3 / Reduced ≤ 1			
Noise Level	dB [A]	*13	≤ 71			
Protection Class	--	*14	IP54 (IP65)			
Ambient Temperature	[°C]	--	0 - 40			
Permitted Housing Temperature	[°C]	--	90			
Weight	[kg]	*15	7.8			

VRT 110 2-Stage Specifications

Frame Size	110					
Ratio	Unit	Note	16	20	25	28
Nominal Output Torque	[Nm]	*1	200	220	280	280
Maximum Acceleration Torque	[Nm]	*2	390	390	390	390
Maximum Torque	[Nm]	*3	390	390	390	390
Emergency Stop Torque	[Nm]	*4	625	625	625	625
Nominal Input Speed	[rpm]	*5	3100	3100	3100	3100
Maximum Input Speed	[rpm]	*6	6500	6500	6500	6500
No Load Running Torque	[Nm]	*7	0.17			
Maximum Radial Load	[N]	*8	12000			
Maximum Axial Load	[N]	*9	8800			
Maximum Tilting Moment	[Nm]	*10	990			
Moment of Inertia ($\leq \varnothing 8$)	[kgcm ²]	--	-	--	--	--
Moment of Inertia ($\leq \varnothing 14$)	[kgcm ²]	--	1.0	0.76	0.73	0.94
Moment of Inertia ($\leq \varnothing 19$)	[kgcm ²]	--	1.4	1.1	1.1	1.3
Moment of Inertia ($\leq \varnothing 28$)	[kgcm ²]	--	3.2	2.9	2.9	3.1
Moment of Inertia ($\leq \varnothing 38$)	[kgcm ²]	--	9.5	9.2	9.1	9.4
Efficiency	[%]	*11	90			
Torsional Rigidity	[Nm/arcmin]	*12	81	81	83	80
Maximum Torsional Backlash	[Arc-min]	--	Standard ≤ 3 / Reduced ≤ 1			
Noise Level	dB [A]	*13	≤ 71			
Protection Class	--	*14	IP54 (IP65)			
Ambient Temperature	[°C]	--	0 - 40			
Permitted Housing Temperature	[°C]	--	90			
Weight	[kg]	*15	8.6			

VRT 110 2-Stage Specifications

Frame Size	110							
Ratio	Unit	Note	35	40	50	70	100	
Nominal Output Torque	[Nm]	*1	280	270	280	280	220	
Maximum Acceleration Torque	[Nm]	*2	390	390	390	390	292	
Maximum Torque	[Nm]	*3	390	390	390	390	292	
Emergency Stop Torque	[Nm]	*4	625	625	625	625	500	
Nominal Input Speed	[rpm]	*5	3100	3100	3500	4200	4200	
Maximum Input Speed	[rpm]	*6	6500	6500	6500	6500	6500	
No Load Running Torque	[Nm]	*7	0.17					
Maximum Radial Load	[N]	*8	12000					
Maximum Axial Load	[N]	*9	8800					
Maximum Tilting Moment	[Nm]	*10	990					
Moment of Inertia ($\leq \varnothing 8$)	[kgcm ²]	--	--	--	0.20	0.19	0.19	
Moment of Inertia ($\leq \varnothing 14$)	[kgcm ²]	--	0.70	0.38	0.37	0.36	0.36	
Moment of Inertia ($\leq \varnothing 19$)	[kgcm ²]	--	1.1	0.78	0.77	0.76	0.76	
Moment of Inertia ($\leq \varnothing 28$)	[kgcm ²]	--	2.8	2.5	2.5	2.5	2.5	
Moment of Inertia ($\leq \varnothing 38$)	[kgcm ²]	--	9.1	8.8	8.8	8.8	8.8	
Efficiency	[%]	*11	90					
Torsional Rigidity	[Nm/arcmin]	*12	82	76	80	71	60	
Maximum Torsional Backlash	[Arc-min]	--	Standard ≤ 3 / Reduced ≤ 1					
Noise Level	dB [A]	*13	≤ 71					
Protection Class	--	*14	IP54 (IP65)					
Ambient Temperature	[°C]	--	0 - 40					
Permitted Housing Temperature	[°C]	--	90					
Weight	[kg]	*15	8.6					

*1) At nominal input speed, service life is 20,000 hours

*2) The maximum torque when starting or stopping operation. Apply Cycle Factor f_0 , found on page 468, for higher duty cycle applications

*3) Permitted 10,000 times during service life. Based on 10% of maximum radial load and smooth output shaft

*4) The maximum torque allowed under a stress situation. Permitted 1,000 times during service life

*5) The average input speed at nominal input torque. Maintain housing temperature below permitted value

*6) The maximum intermittent input speed

*7) Torque at no load applied to the input shaft at nominal input speed

*8) The maximum radial load that the gearbox can accept

*9) The maximum axial load that the gearbox can accept

*10) The maximum load at output flange surface

*11) The efficiency at the nominal output torque rating

*12) This does not include lost motion

*13) Contact Nidec Drive Technology for the testing conditions and environment

*14) IP65 (wash-down) is available as an option. Contact Nidec Drive Technology for more details

*15) Weight may vary slightly between models

VRT SERIES Inline Planetary

VRT 110 1-Stage Dimensions

Input bore size $\leq \varnothing 19\text{ mm}$

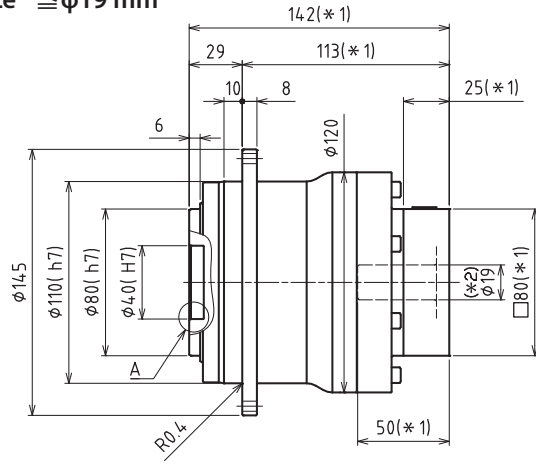
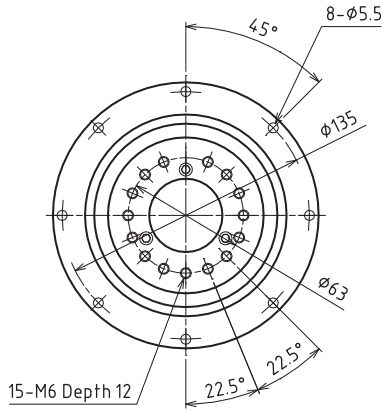

Input bore size $\leq \varnothing 28\text{ mm}$

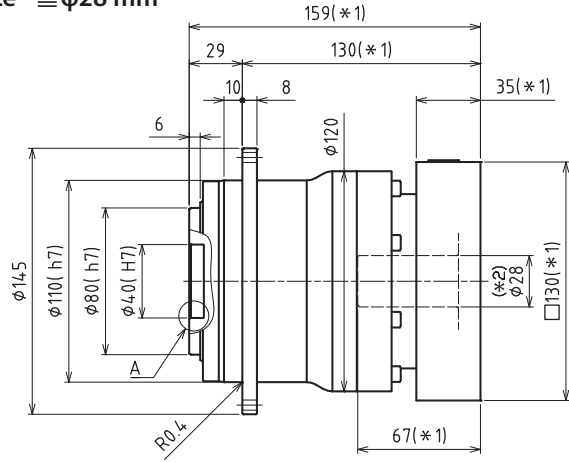
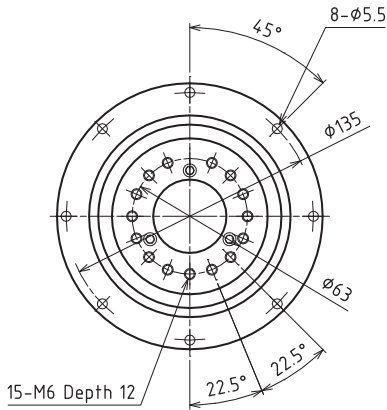

Input bore size $\leq \varnothing 38\text{ mm}$

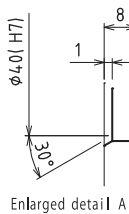
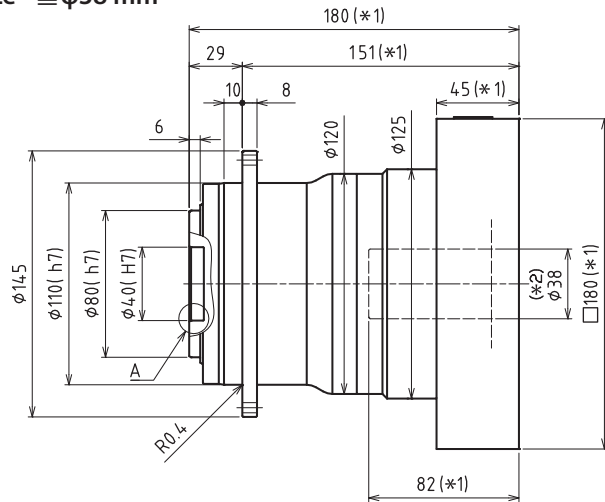
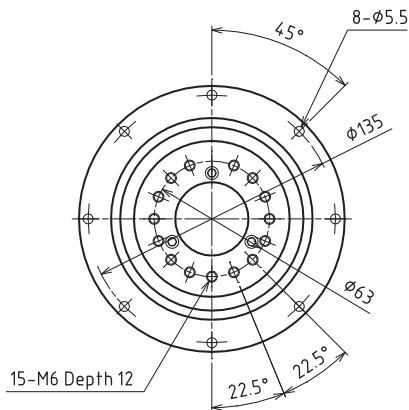

*1) Length will vary depending on motor

*2) Bushing will be inserted to adapt to motor shaft

VRT 110 2-Stage Dimensions

Input bore size $\geq \phi 14$ mm

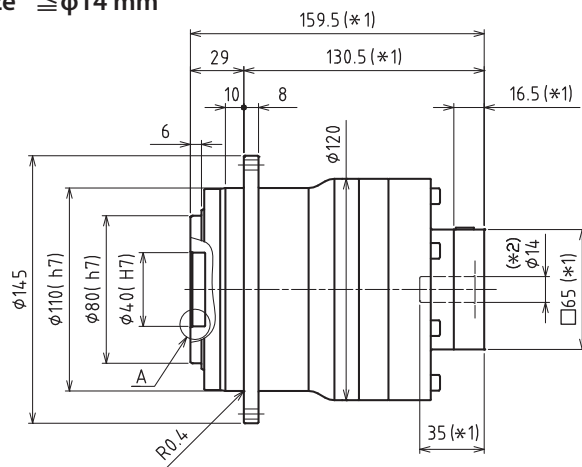
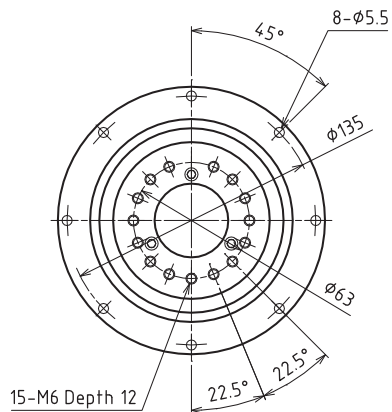

Input bore size $\geq \phi 19$ mm

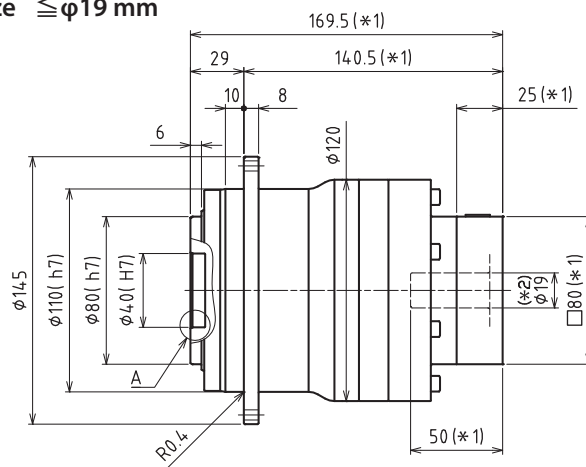
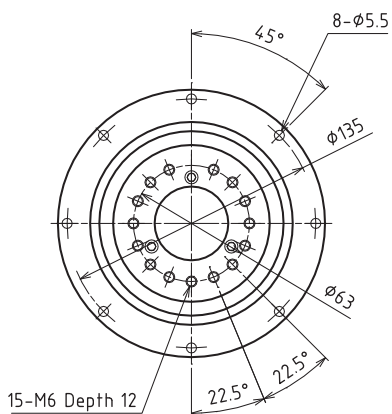

Input bore size $\geq \phi 28$ mm^(*3)

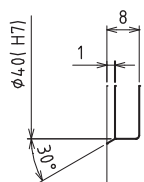
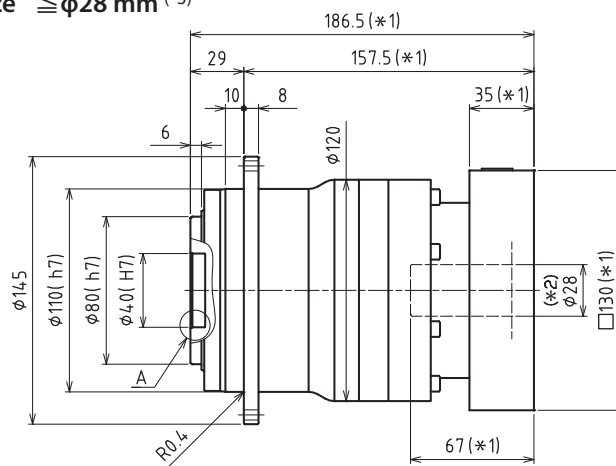
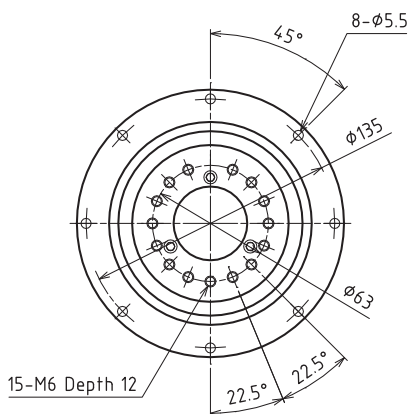

Enlarged detail A

*1) Length will vary depending on motor

*2) Bushing will be inserted to adapt to motor shaft

*3) 38mm input bore is available for this frame size. Use our online configurator to make your selection or contact us for assistance

VRT 140 1-Stage Specifications

Frame Size	140					
Ratio	Unit	Note	4	5	7	10
Nominal Output Torque	[Nm]	*1	280	380	380	380
Maximum Acceleration Torque	[Nm]	*2	840	840	840	610
Maximum Torque	[Nm]	*3	1000	1000	950	730
Emergency Stop Torque	[Nm]	*4	1250	1250	1250	1000
Nominal Input Speed	[rpm]	*5	2100	2100	2600	2600
Maximum Input Speed	[rpm]	*6	5000	5000	5000	5000
No Load Running Torque	[Nm]	*7	1.00			
Maximum Radial Load	[N]	*8	19000			
Maximum Axial Load	[N]	*9	14000			
Maximum Tilting Moment	[Nm]	*10	2000			
Moment of Inertia ($\leq \varnothing 14$)	[kgcm ²]	--	--	--	--	--
Moment of Inertia ($\leq \varnothing 19$)	[kgcm ²]	--	--	--	--	--
Moment of Inertia ($\leq \varnothing 28$)	[kgcm ²]	--	11	7.7	5.1	3.8
Moment of Inertia ($\leq \varnothing 38$)	[kgcm ²]	--	18	14	12	10
Moment of Inertia ($\leq \varnothing 48$)	[kgcm ²]	--	33	29	27	25
Efficiency	[%]	*11	95			
Torsional Rigidity	[Nm/arcmin]	*12	190	187	159	140
Maximum Torsional Backlash	[Arc-min]	*13	Standard ≤ 3 / Reduced ≤ 1			
Noise Level	dB [A]	--	≤ 67			
Protection Class	--	*14	IP54 (IP65)			
Ambient Temperature	[°C]	--	0 - 40			
Permitted Housing Temperature	[°C]	--	90			
Weight	[kg]	*15	15			

VRT 140 2-Stage Specifications

Frame Size	140					
Ratio	Unit	Note	16	20	25	28
Nominal Output Torque	[Nm]	*1	380	410	590	590
Maximum Acceleration Torque	[Nm]	*2	840	840	840	840
Maximum Torque	[Nm]	*3	840	840	840	840
Emergency Stop Torque	[Nm]	*4	1250	1250	1250	1250
Nominal Input Speed	[rpm]	*5	2900	2900	2900	2900
Maximum Input Speed	[rpm]	*6	6000	6000	6000	6000
No Load Running Torque	[Nm]	*7	0.54			
Maximum Radial Load	[N]	*8	19000			
Maximum Axial Load	[N]	*9	14000			
Maximum Tilting Moment	[Nm]	*10	2000			
Moment of Inertia ($\leq \varnothing 14$)	[kgcm ²]	--	--	--	--	--
Moment of Inertia ($\leq \varnothing 19$)	[kgcm ²]	--	3.8	2.6	2.5	3.4
Moment of Inertia ($\leq \varnothing 28$)	[kgcm ²]	--	5.5	4.3	4.2	5.1
Moment of Inertia ($\leq \varnothing 38$)	[kgcm ²]	--	12	11	11	11
Moment of Inertia ($\leq \varnothing 48$)	[kgcm ²]	--	27	26	25	26
Efficiency	[%]	*11	90			
Torsional Rigidity	[Nm/arcmin]	*12	180	185	180	180
Maximum Torsional Backlash	[Arc-min]	*13	Standard ≤ 3 / Reduced ≤ 1			
Noise Level	dB [A]	--	≤ 67			
Protection Class	--	*14	IP54 (IP65)			
Ambient Temperature	[°C]	--	0 - 40			
Permitted Housing Temperature	[°C]	--	90			
Weight	[kg]	*15	17			

VRT 140 2-Stage Specifications

Frame Size	140							
Ratio	Unit	Note	35	40	50	70	100	
Nominal Output Torque	[Nm]	*1	590	500	590	590	440	
Maximum Acceleration Torque	[Nm]	*2	840	840	840	840	610	
Maximum Torque	[Nm]	*3	840	840	840	840	610	
Emergency Stop Torque	[Nm]	*4	1250	1250	1250	1250	1000	
Nominal Input Speed	[rpm]	*5	2900	2900	3200	3900	3900	
Maximum Input Speed	[rpm]	*6	6000	6000	6000	6000	6000	
No Load Running Torque	[Nm]	*7	0.54					
Maximum Radial Load	[N]	*8	19000					
Maximum Axial Load	[N]	*9	14000					
Maximum Tilting Moment	[Nm]	*10	2000					
Moment of Inertia ($\leq \varnothing 14$)	[kgcm ²]	--	--	--	0.68	0.65	0.64	
Moment of Inertia ($\leq \varnothing 19$)	[kgcm ²]	--	2.4	1.1	1.1	1.1	1.1	
Moment of Inertia ($\leq \varnothing 28$)	[kgcm ²]	--	4.1	2.9	2.9	2.8	2.8	
Moment of Inertia ($\leq \varnothing 38$)	[kgcm ²]	--	10	9.2	9.1	9.1	9.1	
Moment of Inertia ($\leq \varnothing 48$)	[kgcm ²]	--	25	24	24	24	24	
Efficiency	[%]	*11	90					
Torsional Rigidity	[Nm/arcmin]	*12	175	175	175	145	140	
Maximum Torsional Backlash	[Arc-min]	*13	Standard ≤ 3 / Reduced ≤ 1					
Noise Level	dB [A]	--	≤ 67					
Protection Class	--	*14	IP54 (IP65)					
Ambient Temperature	[°C]	--	0 - 40					
Permitted Housing Temperature	[°C]	--	90					
Weight	[kg]	*15	17					

*1) At nominal input speed, service life is 20,000 hours

*2) The maximum torque when starting or stopping operation. Apply Cycle Factor f_0 , found on page 468, for higher duty cycle applications

*3) Permitted 10,000 times during service life. Based on 10% of maximum radial load and smooth output shaft

*4) The maximum torque allowed under a stress situation. Permitted 1,000 times during service life

*5) The average input speed at nominal input torque. Maintain housing temperature below permitted value

*6) The maximum intermittent input speed

*7) Torque at no load applied to the input shaft at nominal input speed

*8) The maximum radial load that the gearbox can accept

*9) The maximum axial load that the gearbox can accept

*10) The maximum load at output flange surface

*11) The efficiency at the nominal output torque rating

*12) This does not include lost motion

*13) Contact Nidec Drive Technology for the testing conditions and environment

*14) IP65 (wash-down) is available as an option. Contact Nidec Drive Technology for more details

*15) Weight may vary slightly between models

VRT SERIES Inline Planetary

VRT 140 1-Stage Dimensions

Input bore size $\leq \varnothing 28$ mm

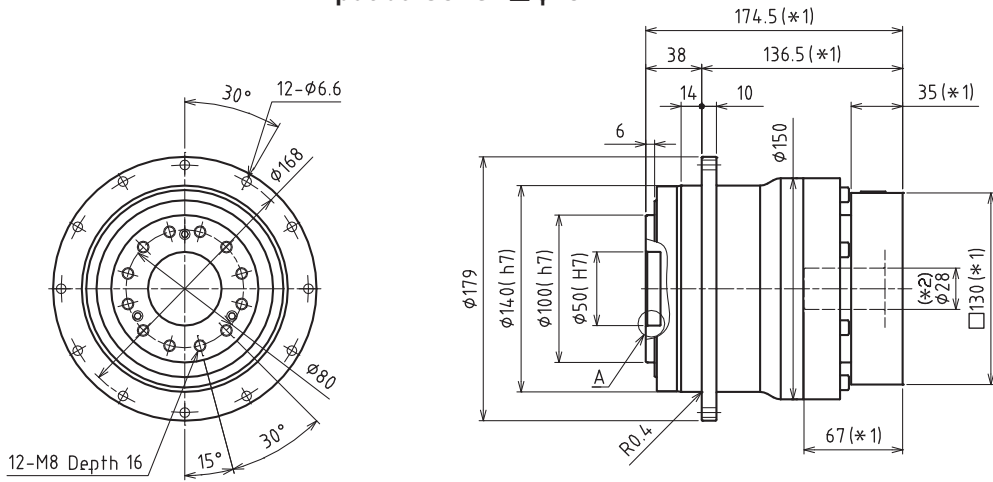

Input bore size $\leq \varnothing 38$ mm

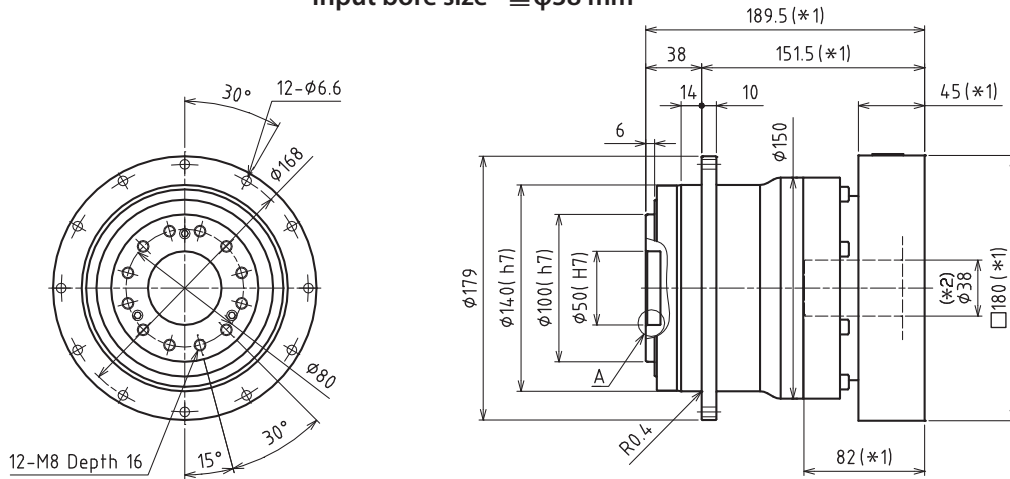

Input bore size $\leq \varnothing 48$ mm

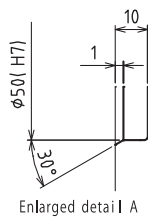
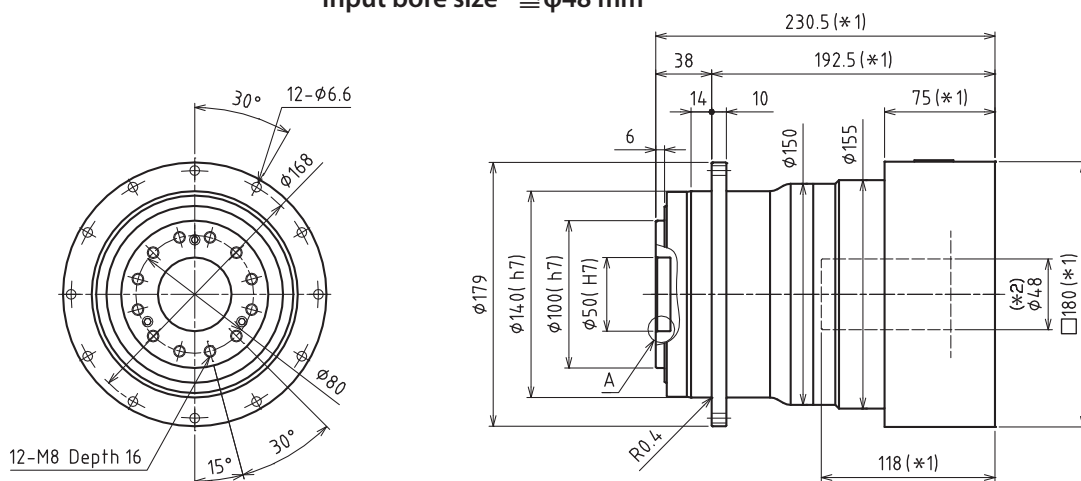

*1) Length will vary depending on motor.

*2) Bushing will be inserted to adapt to motor shaft

VRT 140 2-Stage Dimensions

Input bore size $\leq \varnothing 19$ mm

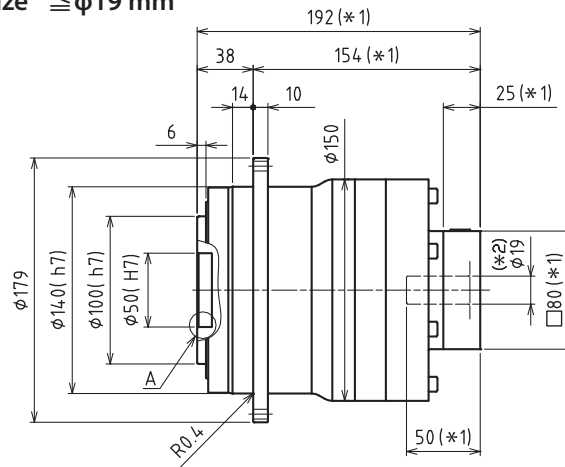
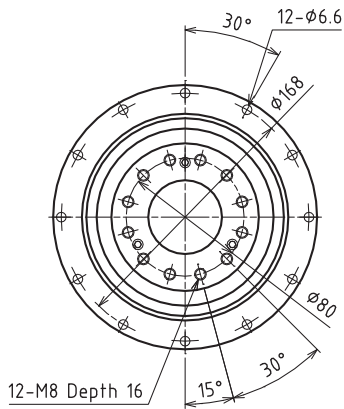

Input bore size $\leq \varnothing 28$ mm

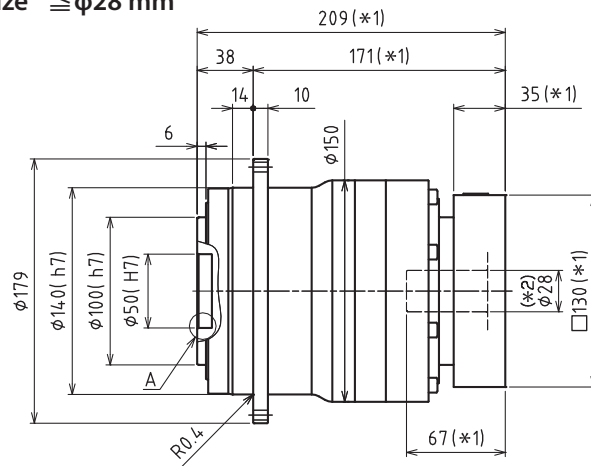
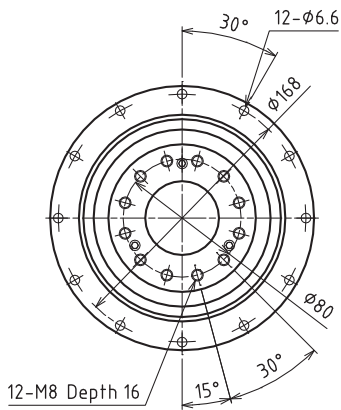

Input bore size $\leq \varnothing 38$ mm^(*3)

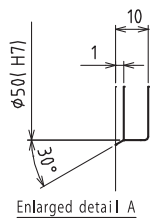
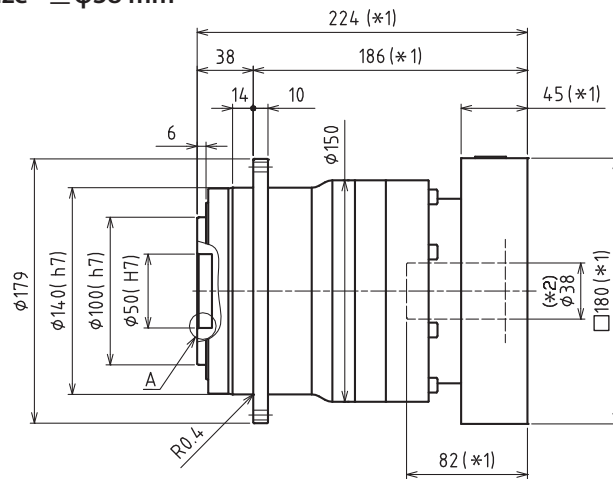
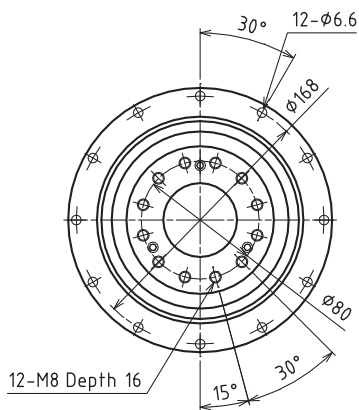

*1) Length will vary depending on motor

*2) Bushing will be inserted to adapt to motor shaft

*3) 48mm input bore is available for this frame size. Use our online configurator to make your selection or contact us for assistance

VRT SERIES Inline Planetary

VRT 200 1-Stage Specifications

Frame Size	200					
Ratio	Unit	Note	4	5	7	10
Nominal Output Torque	[Nm]	*1	850	910	910	910
Maximum Acceleration Torque	[Nm]	*2	1850	1850	1850	1350
Maximum Torque	[Nm]	*3	2250	2250	2150	1750
Emergency Stop Torque	[Nm]	*4	2750	2750	2750	2200
Nominal Input Speed	[rpm]	*5	1500	1500	2300	2300
Maximum Input Speed	[rpm]	*6	4500	4500	4500	4500
No Load Running Torque	[Nm]	*7	1.9			
Maximum Radial Load	[N]	*8	40000			
Maximum Axial Load	[N]	*9	30000			
Maximum Tilting Moment	[Nm]	*10	5300			
Moment of Inertia ($\leq \varnothing 19$)	[kgcm ²]	--	--	--	--	--
Moment of Inertia ($\leq \varnothing 28$)	[kgcm ²]	--	--	--	--	--
Moment of Inertia ($\leq \varnothing 38$)	[kgcm ²]	--	53	36	23	16
Moment of Inertia ($\leq \varnothing 48$)	[kgcm ²]	--	68	51	37	31
Moment of Inertia ($\leq \varnothing 65$)	[kgcm ²]	--	110	95	81	75
Efficiency	[%]	*11	95			
Torsional Rigidity	[Nm/arcmin]	*12	610	610	550	445
Maximum Torsional Backlash	[Arc-min]	*13	Standard ≤ 3 / Reduced ≤ 1			
Noise Level	dB [A]	--	≤ 67			
Protection Class	--	*14	IP54 (IP65)			
Ambient Temperature	[°C]	--	0 - 40			
Permitted Housing Temperature	[°C]	--	90			
Weight	[kg]	*15	42			

VRT 200 2-Stage Specifications

Frame Size	200					
Ratio	Unit	Note	16	20	25	28
Nominal Output Torque	[Nm]	*1	850	910	1100	1300
Maximum Acceleration Torque	[Nm]	*2	1850	1850	1850	1850
Maximum Torque	[Nm]	*3	1850	1850	1850	1850
Emergency Stop Torque	[Nm]	*4	2750	2750	2750	2750
Nominal Input Speed	[rpm]	*5	2700	2700	2700	2700
Maximum Input Speed	[rpm]	*6	5000	5000	5000	5000
No Load Running Torque	[Nm]	*7	1.3			
Maximum Radial Load	[N]	*8	40000			
Maximum Axial Load	[N]	*9	30000			
Maximum Tilting Moment	[Nm]	*10	5300			
Moment of Inertia ($\leq \varnothing 19$)	[kgcm ²]	--	--	--	--	--
Moment of Inertia ($\leq \varnothing 28$)	[kgcm ²]	--	13	9.2	8.6	11
Moment of Inertia ($\leq \varnothing 38$)	[kgcm ²]	--	19	15	15	18
Moment of Inertia ($\leq \varnothing 48$)	[kgcm ²]	--	34	30	30	32
Moment of Inertia ($\leq \varnothing 65$)	[kgcm ²]	--	--	--	--	--
Efficiency	[%]	*11	90			
Torsional Rigidity	[Nm/arcmin]	*12	585	580	570	560
Maximum Torsional Backlash	[Arc-min]	*13	Standard ≤ 3 / Reduced ≤ 1			
Noise Level	dB [A]	--	≤ 67			
Protection Class	--	*14	IP54 (IP65)			
Ambient Temperature	[°C]	--	0 - 40			
Permitted Housing Temperature	[°C]	--	90			
Weight	[kg]	*15	43			

VRT 200 2-Stage Specifications

Frame Size	200							
Ratio	Unit	Note	35	40	50	70	100	
Nominal Output Torque	[Nm]	*1	1300	1200	1300	1300	930	
Maximum Acceleration Torque	[Nm]	*2	1850	1850	1850	1850	1350	
Maximum Torque	[Nm]	*3	1850	1850	1850	1850	1350	
Emergency Stop Torque	[Nm]	*4	2750	2750	2750	2750	2200	
Nominal Input Speed	[rpm]	*5	2700	2700	2900	3400	3400	
Maximum Input Speed	[rpm]	*6	5000	5000	5000	5000	5000	
No Load Running Torque	[Nm]	*7	1.3					
Maximum Radial Load	[N]	*8	40000					
Maximum Axial Load	[N]	*9	30000					
Maximum Tilting Moment	[Nm]	*10	5300					
Moment of Inertia ($\leq \varnothing 19$)	[kgcm ²]	--	--	--	2.1	1.9	1.9	
Moment of Inertia ($\leq \varnothing 28$)	[kgcm ²]	--	8.0	4.1	4.0	3.8	3.8	
Moment of Inertia ($\leq \varnothing 38$)	[kgcm ²]	--	14	10	10	10	10	
Moment of Inertia ($\leq \varnothing 48$)	[kgcm ²]	--	29	25	25	25	25	
Moment of Inertia ($\leq \varnothing 65$)	[kgcm ²]	--	--	--	--	--	--	
Efficiency	[%]	*11	90					
Torsional Rigidity	[Nm/arcmin]	*12	560	520	525	480	395	
Maximum Torsional Backlash	[Arc-min]	*13	Standard ≤ 3 / Reduced ≤ 1					
Noise Level	dB [A]	--	≤ 67					
Protection Class	--	*14	IP54 (IP65)					
Ambient Temperature	[°C]	--	0 - 40					
Permitted Housing Temperature	[°C]	--	90					
Weight	[kg]	*15	43					

*1) At nominal input speed, service life is 20,000 hours

*2) The maximum torque when starting or stopping operation. Apply Cycle Factor f_0 , found on page 468, for higher duty cycle applications

*3) Permitted 10,000 times during service life. Based on 10% of maximum radial load and smooth output shaft

*4) The maximum torque allowed under a stress situation. Permitted 1,000 times during service life

*5) The average input speed at nominal input torque. Maintain housing temperature below permitted value

*6) The maximum intermittent input speed

*7) Torque at no load applied to the input shaft at nominal input speed

*8) The maximum radial load that the gearbox can accept

*9) The maximum axial load that the gearbox can accept

*10) The maximum load at output flange surface

*11) The efficiency at the nominal output torque rating

*12) This does not include lost motion

*13) Contact Nidec Drive Technology for the testing conditions and environment

*14) IP65 (wash-down) is available as an option. Contact Nidec Drive Technology for more details

*15) Weight may vary slightly between models

VRT SERIES Inline Planetary

VRT 200 1-Stage Dimensions

Input bore size $\cong \phi 38$ mm

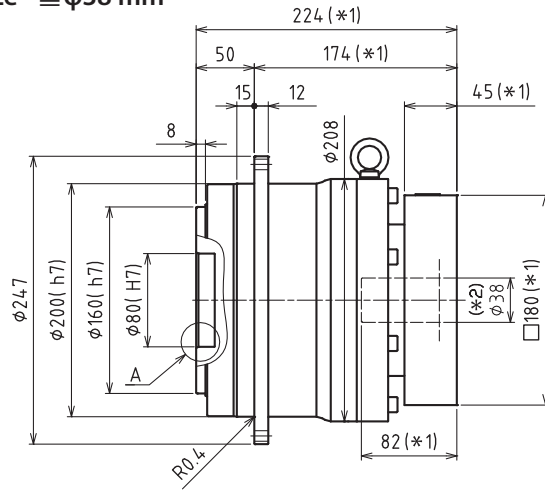
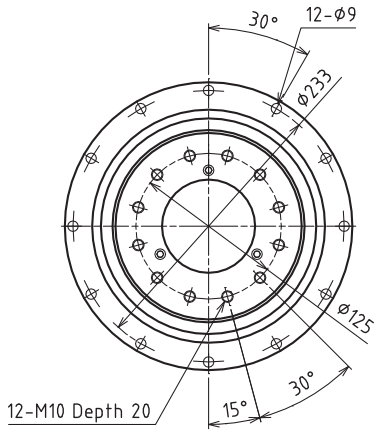

Input bore size $\cong \phi 48$ mm

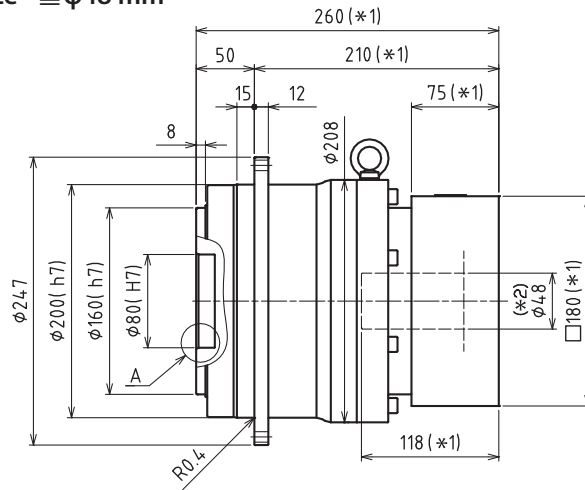
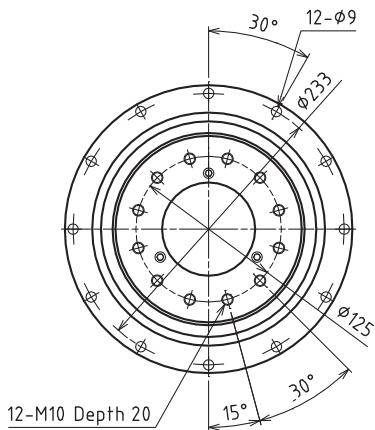

Input bore size $\cong \phi 65$ mm

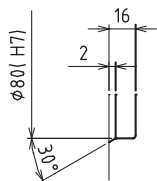
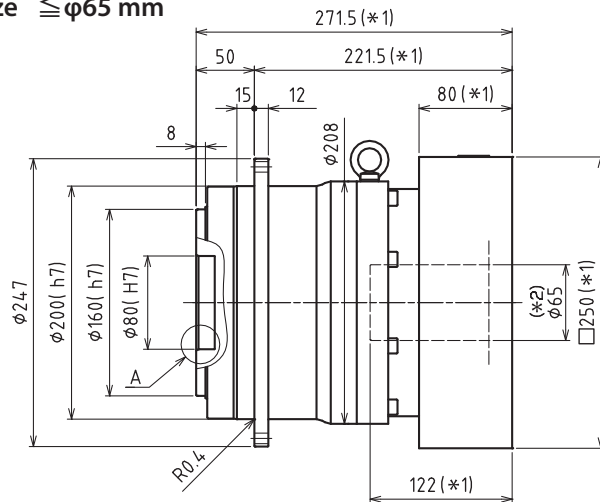
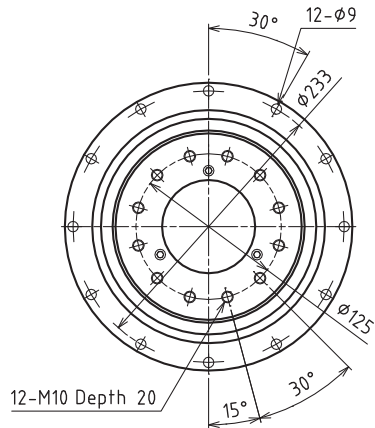

Enlarged detail A

*1) Length will vary depending on motor

*2) Bushing will be inserted to adapt to motor shaft

VRT 200 2-Stage Dimensions

Input bore size $\cong \phi 28$ mm

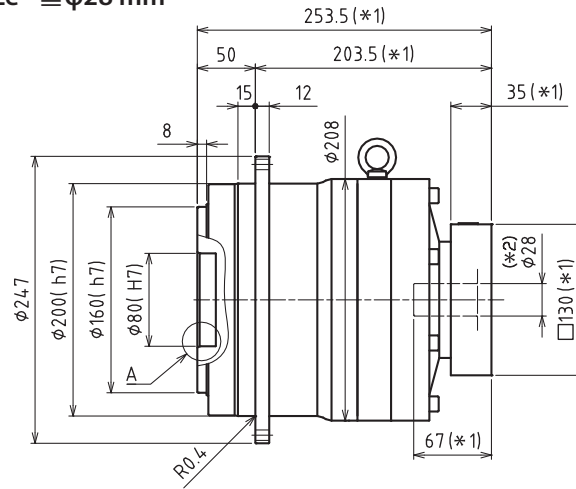
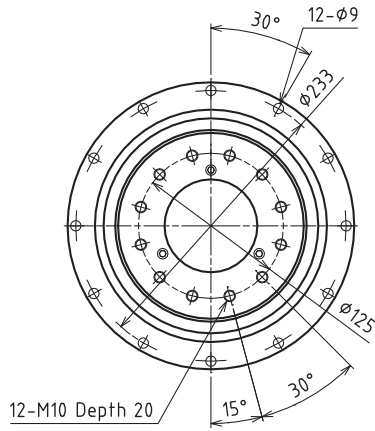

Input bore size $\cong \phi 38$ mm

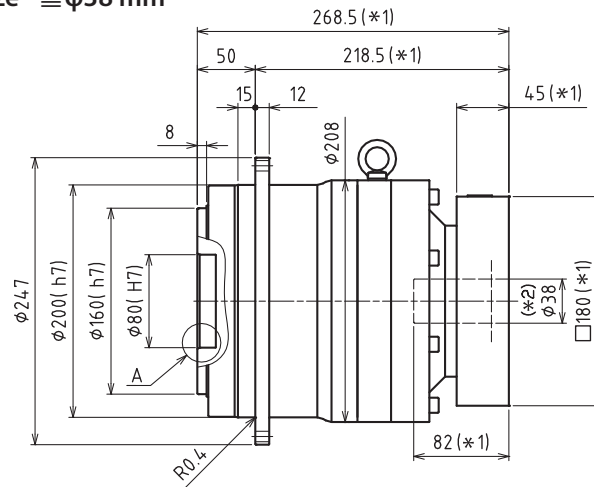
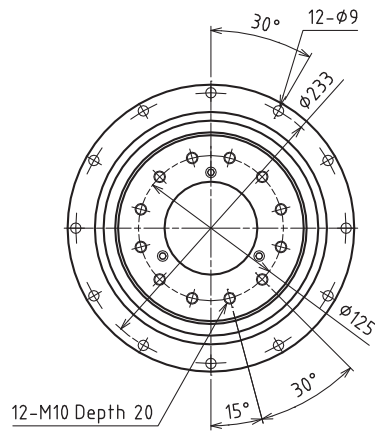

Input bore size $\cong \phi 48$ mm

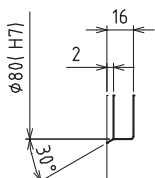
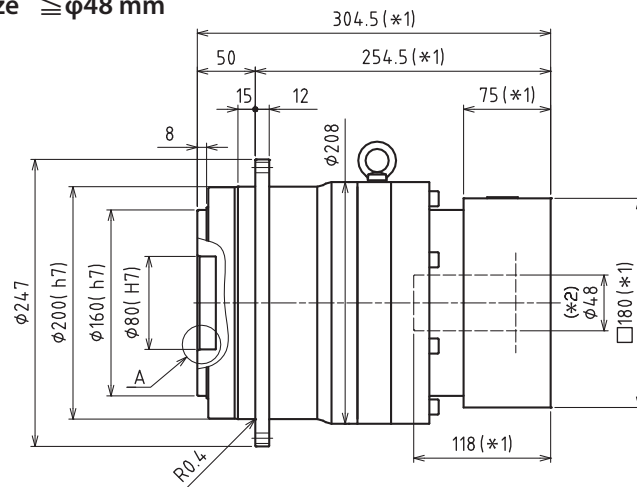
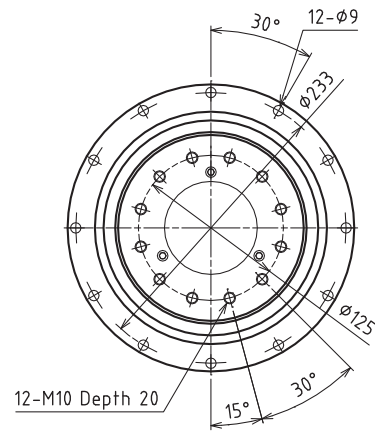

Enlarged detail I A

*1) Length will vary depending on motor

*2) Bushing will be inserted to adapt to motor shaft

VRT SERIES Inline Planetary

VRT 255 1-Stage Specifications

Frame Size	255					
Ratio	Unit	Note	4	5	7	10
Nominal Output Torque	[Nm]	*1	2400	2400	2700	2700
Maximum Acceleration Torque	[Nm]	*2	5100	5100	4800	3600
Maximum Torque	[Nm]	*3	5700	5700	5400	4100
Emergency Stop Torque	[Nm]	*4	8000	8000	8000	6000
Nominal Input Speed	[rpm]	*5	1000	1200	1500	1700
Maximum Input Speed	[rpm]	*6	3000	3000	3000	3000
No Load Running Torque	[Nm]	*7	2.5			
Maximum Radial Load	[N]	*8	64000			
Maximum Axial Load	[N]	*9	48000			
Maximum Tilting Moment	[Nm]	*10	11000			
Moment of Inertia ($\leq \varnothing 38$)	[kgcm ²]	--	--	--	--	--
Moment of Inertia ($\leq \varnothing 48$)	[kgcm ²]	--	--	--	--	--
Moment of Inertia ($\leq \varnothing 65$)	[kgcm ²]	--	180	130	100	84
Efficiency	[%]	*11	95			
Torsional Rigidity	[Nm/arcmin]	*12	840	1000	900	840
Maximum Torsional Backlash	[Arc-min]	*13	≤ 3			
Noise Level	dB [A]	--	≤ 62			
Protection Class	--	*14	IP54 (IP65)			
Ambient Temperature	[°C]	--	0 - 40			
Permitted Housing Temperature	[°C]	--	90			
Weight	[kg]	*15	84			

VRT 255 2-Stage Specifications

Frame Size	255					
Ratio	Unit	Note	16	20	25	28
Nominal Output Torque	[Nm]	*1	2400	2600	3200	3400
Maximum Acceleration Torque	[Nm]	*2	5100	5100	5100	4900
Maximum Torque	[Nm]	*3	5100	5100	5100	4900
Emergency Stop Torque	[Nm]	*4	8000	8000	8000	8000
Nominal Input Speed	[rpm]	*5	2000	2000	2000	2000
Maximum Input Speed	[rpm]	*6	4500	4500	4500	4500
No Load Running Torque	[Nm]	*7	1.0			
Maximum Radial Load	[N]	*8	64000			
Maximum Axial Load	[N]	*9	48000			
Maximum Tilting Moment	[Nm]	*10	11000			
Moment of Inertia ($\leq \varnothing 38$)	[kgcm ²]	--	--	--	--	--
Moment of Inertia ($\leq \varnothing 48$)	[kgcm ²]	--	58	47	45	53
Moment of Inertia ($\leq \varnothing 65$)	[kgcm ²]	--	--	--	--	--
Efficiency	[%]	*11	90			
Torsional Rigidity	[Nm/arcmin]	*12	840	850	950	840
Maximum Torsional Backlash	[Arc-min]	*13	≤ 3			
Noise Level	dB [A]	--	≤ 62			
Protection Class	--	*14	IP54 (IP65)			
Ambient Temperature	[°C]	--	0 - 40			
Permitted Housing Temperature	[°C]	--	90			
Weight	[kg]	*15	89			

VRT 255 2-Stage Specifications

Frame Size	255							
Ratio	Unit	Note	35	40	50	70	100	
Nominal Output Torque	[Nm]	*1	3400	3400	3400	3400	2000	
Maximum Acceleration Torque	[Nm]	*2	4900	5100	5100	4900	2500	
Maximum Torque	[Nm]	*3	4900	5100	5100	4900	2500	
Emergency Stop Torque	[Nm]	*4	8000	8000	8000	8000	6000	
Nominal Input Speed	[rpm]	*5	2000	2000	2200	2800	2800	
Maximum Input Speed	[rpm]	*6	4500	4500	4500	4500	4500	
No Load Running Torque	[Nm]	*7	1.0					
Maximum Radial Load	[N]	*8	64000					
Maximum Axial Load	[N]	*9	48000					
Maximum Tilting Moment	[Nm]	*10	11000					
Moment of Inertia ($\leq \varnothing 38$)	[kgcm ²]	--	--	--	14	13	13	
Moment of Inertia ($\leq \varnothing 48$)	[kgcm ²]	--	44	32	32	31	31	
Moment of Inertia ($\leq \varnothing 65$)	[kgcm ²]	--	--	--	--	--	--	
Efficiency	[%]	*11	90					
Torsional Rigidity	[Nm/arcmin]	*12	900	840	840	840	840	
Maximum Torsional Backlash	[Arc-min]	*13	≤ 3					
Noise Level	dB [A]	--	≤ 62					
Protection Class	--	*14	IP54 (IP65)					
Ambient Temperature	[°C]	--	0 - 40					
Permitted Housing Temperature	[°C]	--	90					
Weight	[kg]	*15	89					

*1) At nominal input speed, service life is 20,000 hours

*2) The maximum torque when starting or stopping operation. Apply Cycle Factor f_0 , found on page 468, for higher duty cycle applications

*3) Permitted 10,000 times during service life. Based on 10% of maximum radial load and smooth output shaft

*4) The maximum torque allowed under a stress situation. Permitted 1,000 times during service life

*5) The average input speed at nominal input torque. Maintain housing temperature below permitted value

*6) The maximum intermittent input speed

*7) Torque at no load applied to the input shaft at nominal input speed

*8) The maximum radial load that the gearbox can accept

*9) The maximum axial load that the gearbox can accept

*10) The maximum load at output flange surface

*11) The efficiency at the nominal output torque rating

*12) This does not include lost motion

*13) Contact Nidec Drive Technology for the testing conditions and environment

*14) IP65 (wash-down) is available as an option. Contact Nidec Drive Technology for more details

*15) Weight may vary slightly between models

VRT SERIES Inline Planetary

VRT 255 1-Stage Dimensions

Input bore size $\leq \phi 65 \text{ mm}$

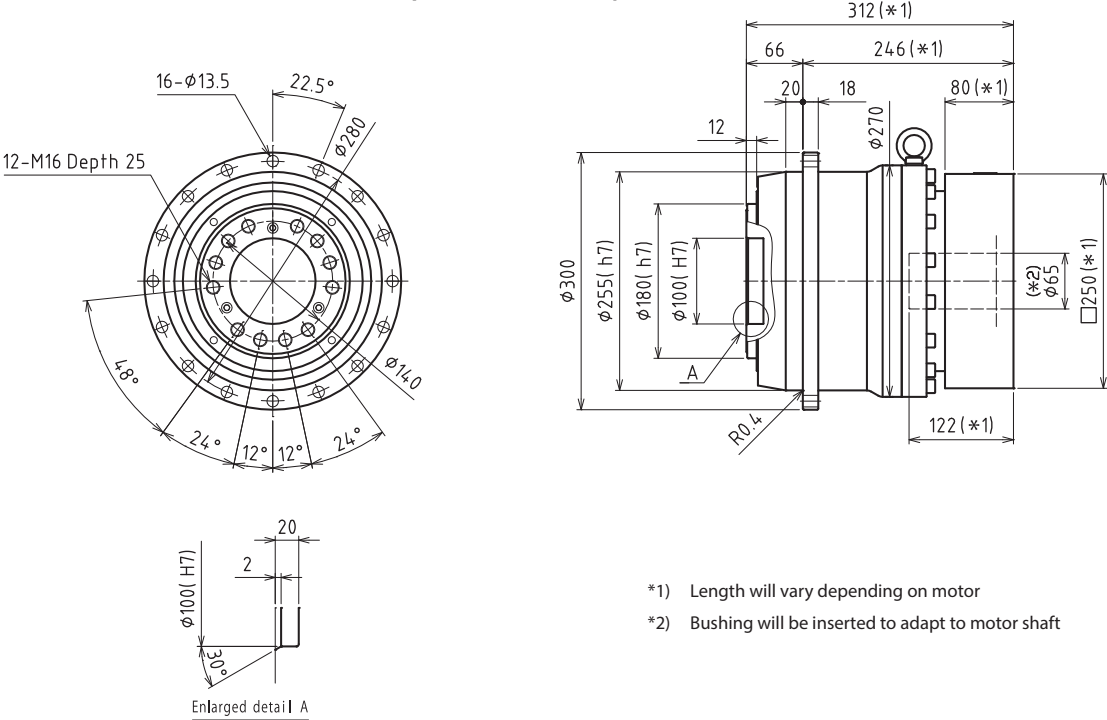

- *1) Length will vary depending on motor
- *2) Bushing will be inserted to adapt to motor shaft

VRT 255 2-Stage Dimensions

Input bore size $\leq \phi 48$ mm

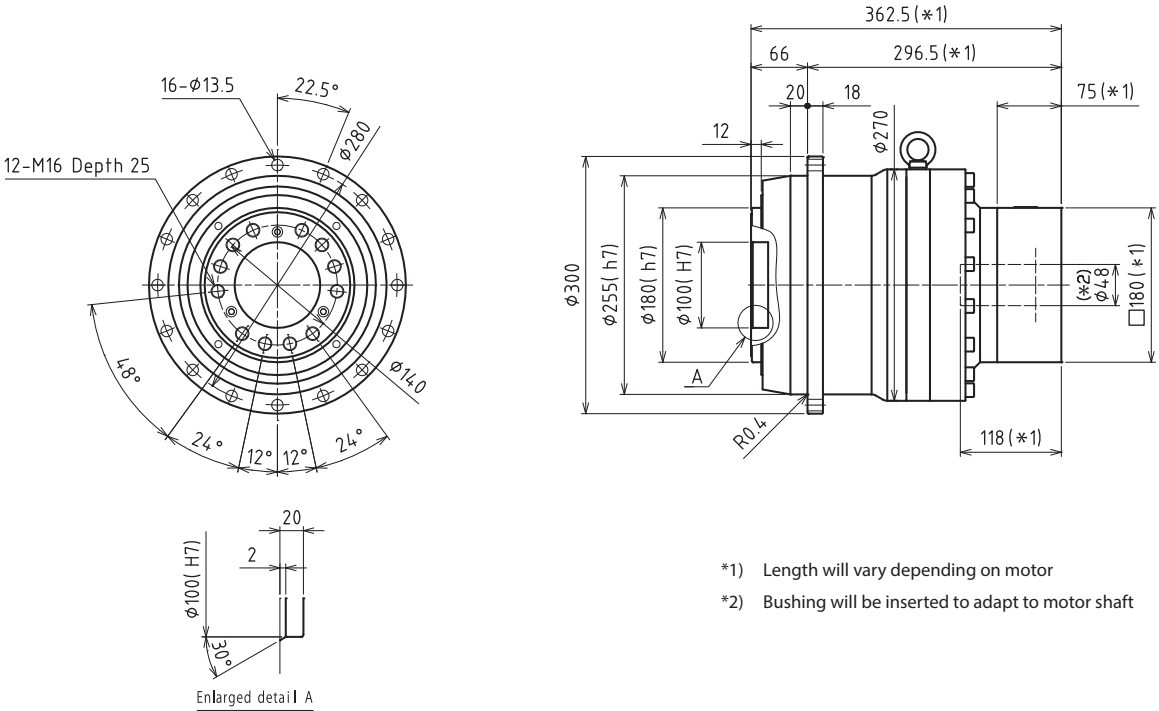

- *1) Length will vary depending on motor
- *2) Bushing will be inserted to adapt to motor shaft

VRT 285 1-Stage Specifications

Frame Size	285					
Ratio	Unit	Note	4	5	7	10
Nominal Output Torque	[Nm]	*1	3400	3400	3400	3400
Maximum Acceleration Torque	[Nm]	*2	6700	6700	6700	5100
Maximum Torque	[Nm]	*3	7500	7500	7500	5900
Emergency Stop Torque	[Nm]	*4	12000	12000	12000	10000
Nominal Input Speed	[rpm]	*5	900	1100	1300	1300
Maximum Input Speed	[rpm]	*6	3000	3000	3000	3000
No Load Running Torque	[Nm]	*7	2.7			
Maximum Radial Load	[N]	*8	86000			
Maximum Axial Load	[N]	*9	64000			
Maximum Tilting Moment	[Nm]	*10	18000			
Moment of Inertia ($\leq \varnothing 38$)	[kgcm ²]	--	--	--	--	--
Moment of Inertia ($\leq \varnothing 48$)	[kgcm ²]	--	--	--	--	--
Moment of Inertia ($\leq \varnothing 65$)	[kgcm ²]	--	270	190	130	96
Efficiency	[%]	*11	95			
Torsional Rigidity	[Nm/arcmin]	*12	1200	1450	1300	1200
Maximum Torsional Backlash	[Arc-min]	*13	≤ 3			
Noise Level	dB [A]	--	≤ 63			
Protection Class	--	*14	IP54 (IP65)			
Ambient Temperature	[°C]	--	0 - 40			
Permitted Housing Temperature	[°C]	--	90			
Weight	[kg]	*15	110			

VRT 285 2-Stage Specifications

Frame Size	285					
Ratio	Unit	Note	16	20	25	28
Nominal Output Torque	[Nm]	*1	2700	2900	3600	4200
Maximum Acceleration Torque	[Nm]	*2	6700	6700	6700	6700
Maximum Torque	[Nm]	*3	6700	6700	6700	6700
Emergency Stop Torque	[Nm]	*4	12000	12000	12000	12000
Nominal Input Speed	[rpm]	*5	1500	1500	1500	1500
Maximum Input Speed	[rpm]	*6	4000	4000	4000	4000
No Load Running Torque	[Nm]	*7	0.6			
Maximum Radial Load	[N]	*8	86000			
Maximum Axial Load	[N]	*9	64000			
Maximum Tilting Moment	[Nm]	*10	18000			
Moment of Inertia ($\leq \varnothing 38$)	[kgcm ²]	--	--	--	--	--
Moment of Inertia ($\leq \varnothing 48$)	[kgcm ²]	--	63	50	47	55
Moment of Inertia ($\leq \varnothing 65$)	[kgcm ²]	--	--	--	--	--
Efficiency	[%]	*11	90			
Torsional Rigidity	[Nm/arcmin]	*12	1200	1400	1450	1200
Maximum Torsional Backlash	[Arc-min]	*13	≤ 3			
Noise Level	dB [A]	--	≤ 63			
Protection Class	--	*14	IP54 (IP65)			
Ambient Temperature	[°C]	--	0 - 40			
Permitted Housing Temperature	[°C]	--	90			
Weight	[kg]	*15	120			

VRT 285 2-Stage Specifications

Frame Size	285							
Ratio	Unit	Note	35	40	50	70	100	
Nominal Output Torque	[Nm]	*1	4200	4200	4200	4200	2700	
Maximum Acceleration Torque	[Nm]	*2	6700	6700	6700	6700	3400	
Maximum Torque	[Nm]	*3	6700	6700	6700	6700	3400	
Emergency Stop Torque	[Nm]	*4	12000	12000	12000	12000	10000	
Nominal Input Speed	[rpm]	*5	1500	1500	2000	2200	2200	
Maximum Input Speed	[rpm]	*6	4000	4000	4000	4000	4000	
No Load Running Torque	[Nm]	*7	0.6					
Maximum Radial Load	[N]	*8	86000					
Maximum Axial Load	[N]	*9	64000					
Maximum Tilting Moment	[Nm]	*10	18000					
Moment of Inertia ($\leq \varnothing 38$)	[kgcm ²]	--	--	--	14	14	13	
Moment of Inertia ($\leq \varnothing 48$)	[kgcm ²]	--	45	33	32	31	31	
Moment of Inertia ($\leq \varnothing 65$)	[kgcm ²]	--	--	--	--	--	--	
Efficiency	[%]	*11	90					
Torsional Rigidity	[Nm/arcmin]	*12	1400	1200	1300	1250	1200	
Maximum Torsional Backlash	[Arc-min]	*13	≤ 3					
Noise Level	dB [A]	--	≤ 63					
Protection Class	--	*14	IP54 (IP65)					
Ambient Temperature	[°C]	--	0 - 40					
Permitted Housing Temperature	[°C]	--	90					
Weight	[kg]	*15	120					

- *1) At nominal input speed, service life is 20,000 hours
- *2) The maximum torque when starting or stopping operation. Apply Cycle Factor f_0 , found on page 468, for higher duty cycle applications
- *3) Permitted 10,000 times during service life. Based on 10% of maximum radial load and smooth output shaft
- *4) The maximum torque allowed under a stress situation. Permitted 1,000 times during service life
- *5) The average input speed at nominal input torque. Maintain housing temperature below permitted value
- *6) The maximum intermittent input speed
- *7) Torque at no load applied to the input shaft at nominal input speed
- *8) The maximum radial load that the gearbox can accept
- *9) The maximum axial load that the gearbox can accept
- *10) The maximum load at output flange surface
- *11) The efficiency at the nominal output torque rating
- *12) This does not include lost motion
- *13) Contact Nidec Drive Technology for the testing conditions and environment
- *14) IP65 (wash-down) is available as an option. Contact Nidec Drive Technology for more details
- *15) Weight may vary slightly between models

VRT SERIES Inline Planetary

VRT 285 1-Stage Dimensions

Input bore size $\cong \phi 65$ mm

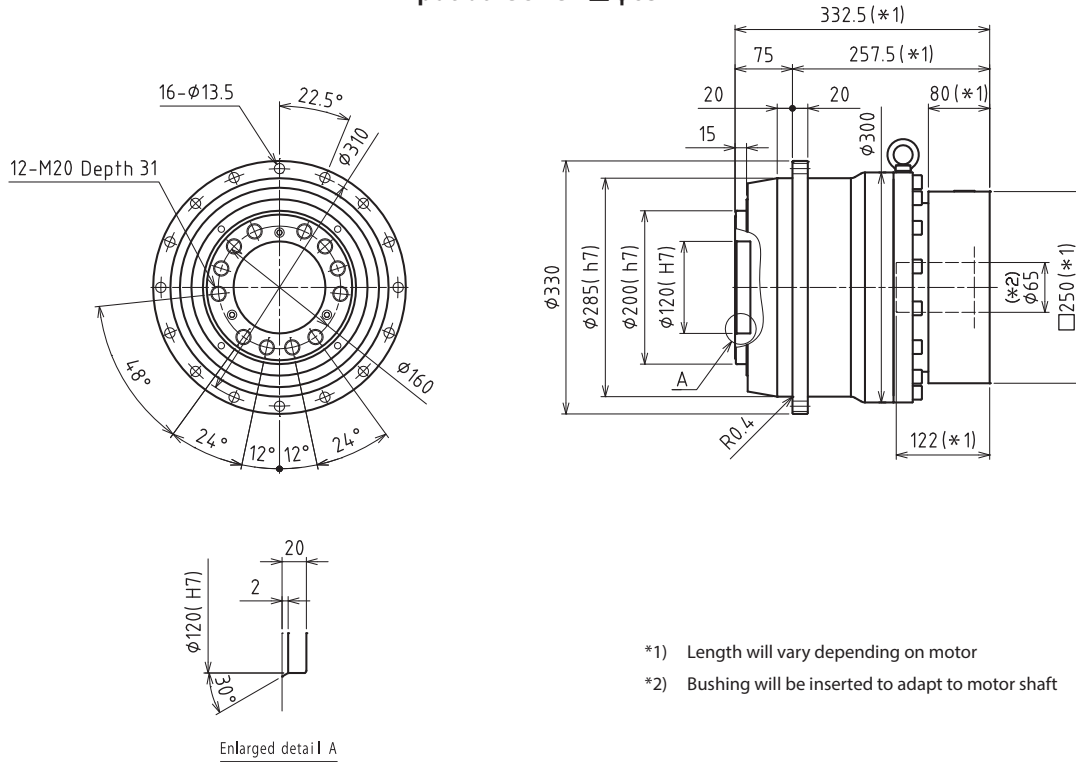

- *1) Length will vary depending on motor
- *2) Bushing will be inserted to adapt to motor shaft

VRT 285 2-Stage Dimensions

Input bore size $\leq \phi 48$ mm

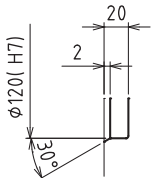
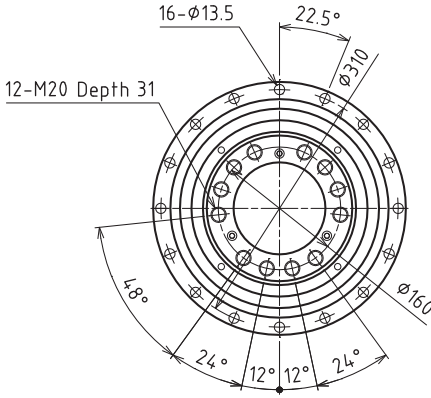

Enlarged detail I A

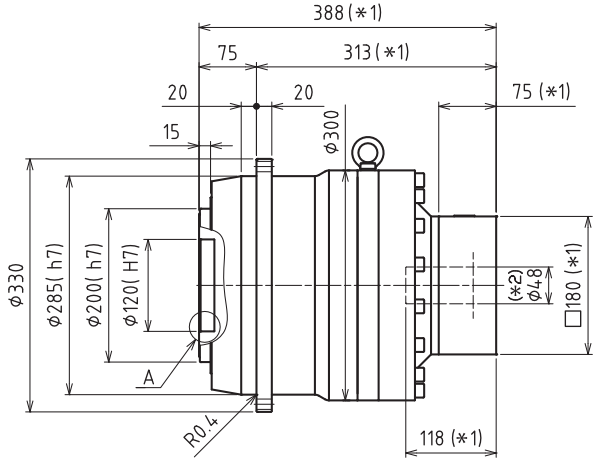

- *1) Length will vary depending on motor
- *2) Bushing will be inserted to adapt to motor shaft