

U.S. PATENTED

IKO

Micro Linear Way

LWL



See you again at
IKO Website
<http://www.ikont.co.jp/eg/>

CAT-57143

Micro Linear Way L for downsizing your machines

IKO Micro Linear Way is the smallest linear motion rolling guide having precise and smooth motion developed by IKO's original miniature technology.

Track rail width can be chosen from 1mm to 6mm and that suites to precise positioning in your micro machine.

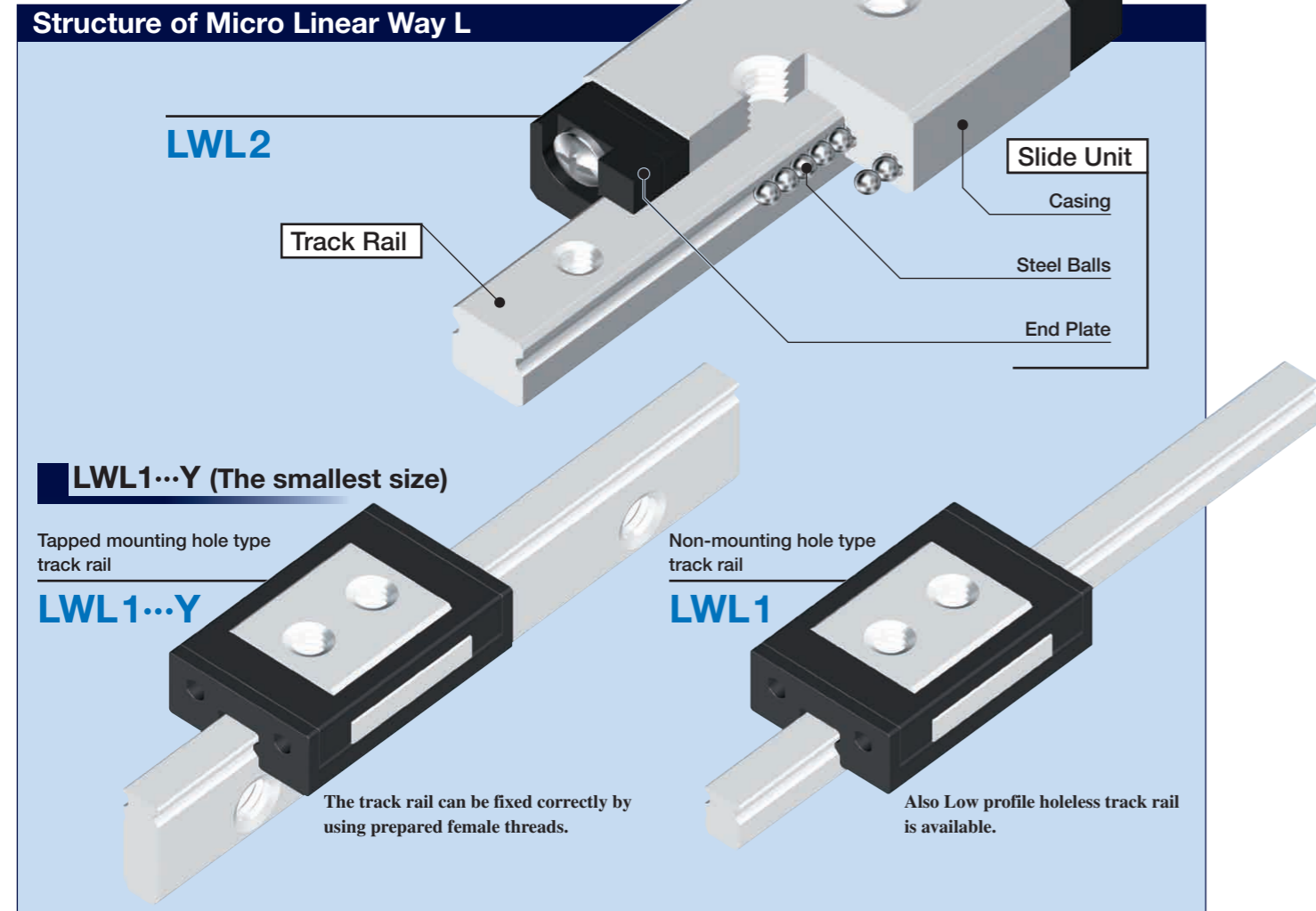

Simple structure for controlling accuracy and micro-sizing

All IKO Linear Way features unique design in which large diameter steel balls contacting raceways at four points each are arranged in two rows. High level of accuracy, even in Micro Linear Way, is realized by IKO's all of accumulated linear motion technology and this simple structure.

U.S. Patent

No. 5,435,649	No. 4,505,522
No. 5,289,779	No. 6,176,617
No. 5,250,126	No. 6,082,899
No. 4,652,147	No. 5,967,667

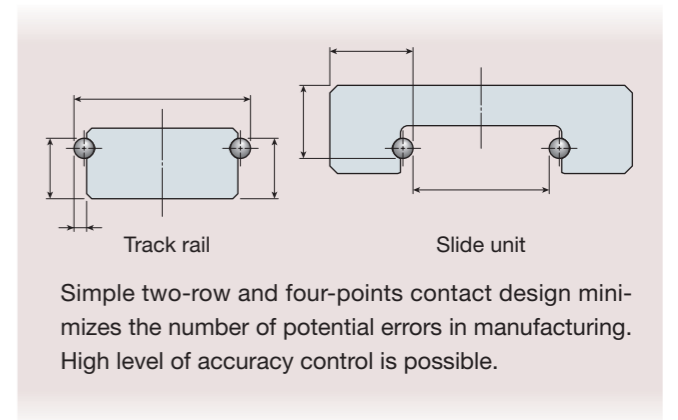
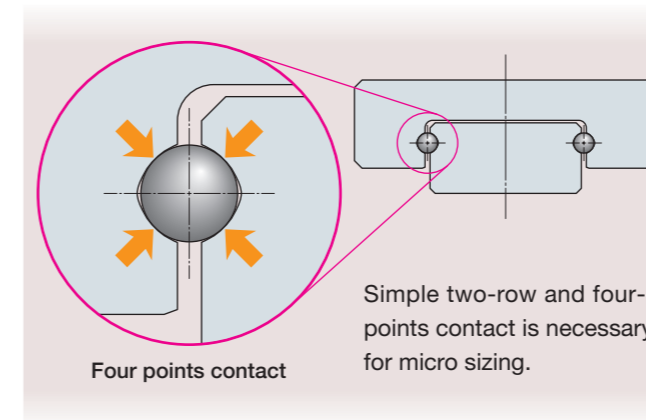

For special specification

Stainless Steel made

All products are made by stainless steel which is highly corrosion resistance. This is suitable for the use in clean rooms and places where rust preventive oil should be avoided or kept to a minimum.

Special Grease /Y

Several greases for clean room application are available. For size 3 and 6, specify a grease by supplemental code if necessary.

Stainless made End Plate /BS

The standard end plate made by resin can be replaced with stainless steel made end plate. It is suitable for vacuum and high temperature application. Applicable to size 2 and 3.



Micro Linear Way LWL is suitable for optical fiber communication device, medical equipments, semiconductor manufacturing system, liquid crystal display manufacturing process, etc.



IKO Micro Linear Way LWL

Wide variation

There is a great variation in sizes and shapes.
The best specification can be selected to suite each machine and equipment.

Track rail width; 1mm to 6mm are available.

Standard length slide unit and short type slide unit are available in the same sectional dimension.

Standard type and wide type are available. Wide type is suitable for single row rail arrangement.

Two kinds of track rails, through mounting holes type and female thread mounting holes type, are available.

		Standard type			Wide type	
		LWL1	LWL2	LWL3	LWLF4	LWLF6
Cross section (Full-scale) unit: mm						
	Length of slide unit (Full-scale)	Short	—	—		—
	Standard					
Shape of track rail	Standard track rail		Tapped track rail		Holeless track rail	
		Applicable to size 4 and 6	Applicable to size 2, 3 and 6		Applicable to size 1	
			Tapped track rail (Lateral)			
			Applicable to size 1			

The ultimate IKO miniature technology for super micro machine

Other micro series are also available.
Please consult **IKO** for future information.



Spline shaft diameter: **2mm**

Linear Ball Spline G
LSAG 2, LSAG F 2



Shaft diameter: **2mm**

Miniature Stroke Rotary Bushing
STSI 2

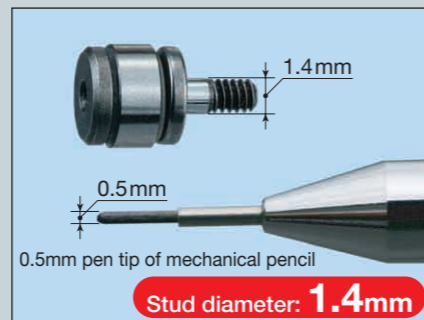

Stud diameter: **1.4mm**

Miniature Cam Follower
CFS 1.4

Super micro 1mm width will take you onto a "Fantastic Voyage"

Accuracy is as high as larger size Linear Ways.

All dimensional tolerances are strictly controlled with the original precision manufacturing technology.
This is the smallest linear motion rolling guide for the places where compactness and high accuracy are required.

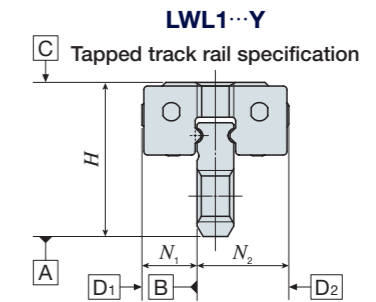

Two female threads are prepared on the top surface of slide unit.

Two fixing bolts help proper alignment.
Both side surfaces of slide unit can be used as reference surfaces, thus universal mounting is possible.

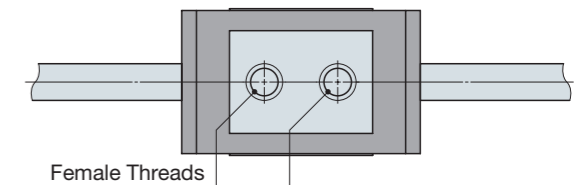

Mounting method (for tapped track rail specification LWL1...Y)

For track rail width 1mm, female threads are prepared for lateral mounting and track rail can be fixed easily and correctly.

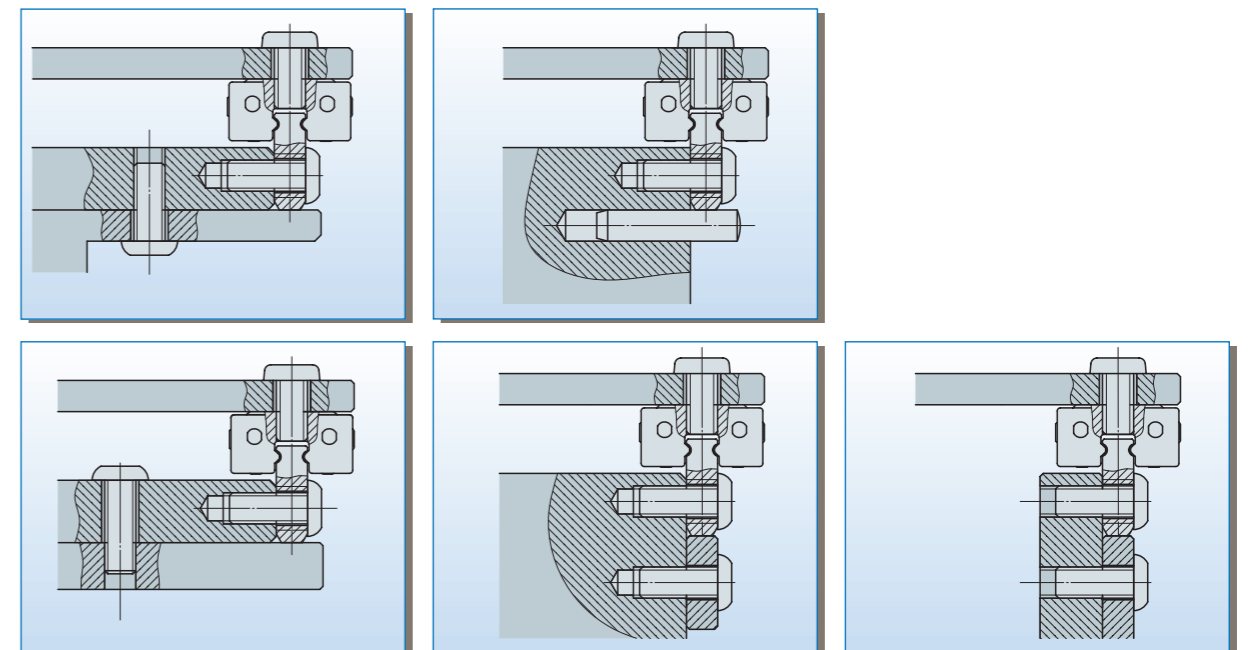
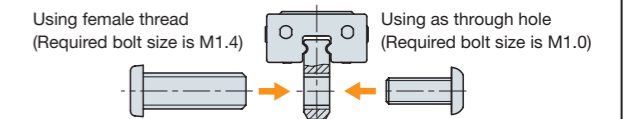

Identification Number

The specification of Micro Linear Way LWL is specified by the identification number, which consists of a model code, a size, a part code, a preload symbol, a classification symbol, interchangeable code and special supplemental codes.

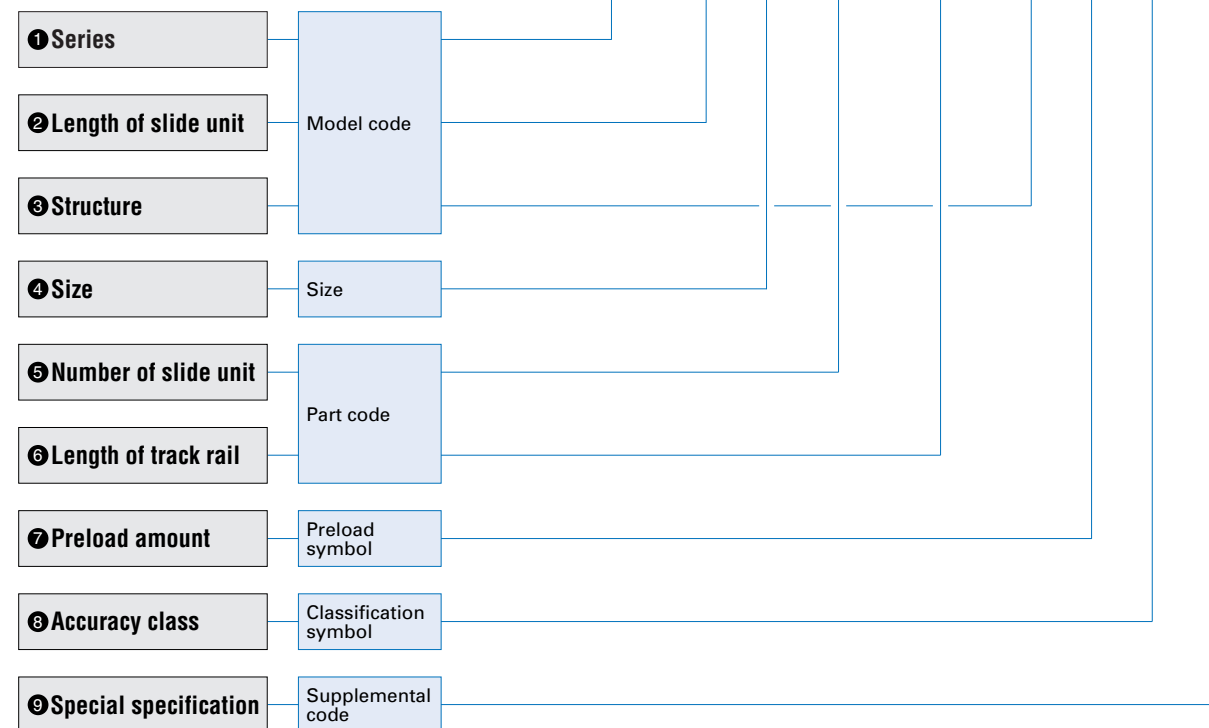
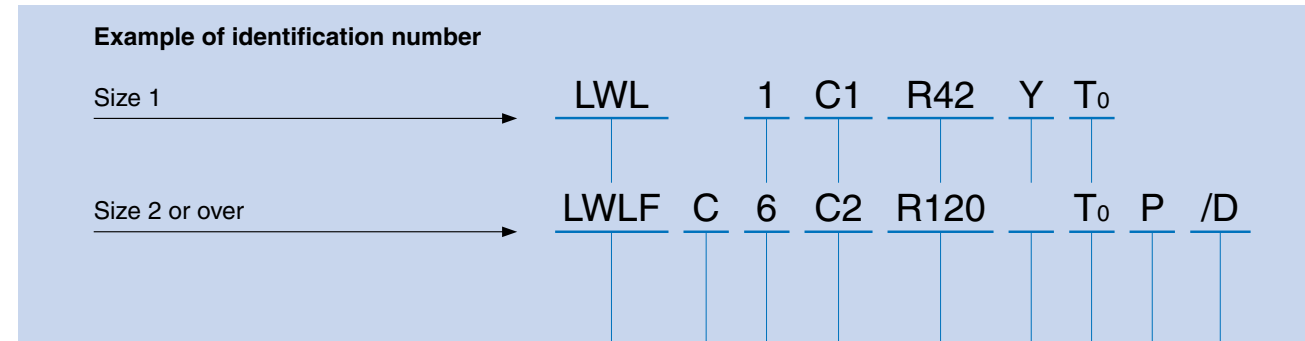

1 Series	Standard type : LWL Wide type : LWLF	
2 Length of slide unit	Short : C Standard : Non symbol	
3 Structure	Standard Tapped track rail specification : Non symbol, Y Non-mounting hole type track rail specification : Non symbol Wide type Tapped track rail specification : Non symbol Non-mounting hole type track rail specification : N	Applicable type and size are shown in Table 1.
4 Size	1, 2, 3, 4 and 6	

Table1 Type and size of Micro Linear Way LWL

Series	Material	Structure	Length of the slide unit	Model code	Size		
					1	2	3
Standard type	Stainless steel	Tapped track rail specification	Short	LWLC	—	—	○
			Standard	LWL	—	○	○
		Non-mounting hole type track rail specification	Standard	LWL...Y	○	—	—
Wide type	Stainless steel	Standard rail specification	Short	LWLFC	—	○	—
			Standard	LWLF	○	○	—
Wide type	Stainless steel	Tapped track rail specification	Short	LWLFC...N	—	○	—
			Standard	LWLF...N	—	○	—

5 Number of slide unit	C ○	Indicate the number of slide units assembled on one track rail.
6 Length of track rail	R ○	Indicate the length of track rail in mm. For standard and maximum lengths, see "Track rail length" in Table 15 on page 15.
7 Preload	Clearance : T ₀	Applicable preload for Micro Linear Way LWL is only T ₀ preload. It is zero or minimal amount of clearance.
8 Accuracy code	High class : H Precision class : P	Accuracy code is applicable for size 2 or over and not applicable for size 1. (No symbol) For applicable accuracy, see Table 2 and Table 3 on page 7.
9 Special specifications	/BS, /D, /E, /I, /MN, /W○, /Y○	Applicable special specifications are shown in Table 4 on page 8. Special specification is not applicable for size 1.

Accuracy

Accuracy of Micro Linear Way LWL is show in Table 2 and 3.

Table 2 Accuracy of Micro Linear Way LWL (for LWL1-Y)

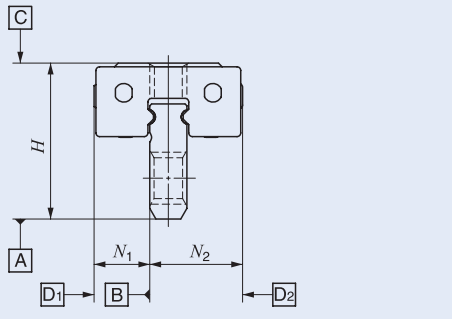

Item	Tolerance
Dim. H tolerance	± 0.020
Dim. N_1 and N_2 tolerance	± 0.025

unit: mm

Table 3 Accuracy of Micro Linear Way LWL (for LWL2 and larger sizes)

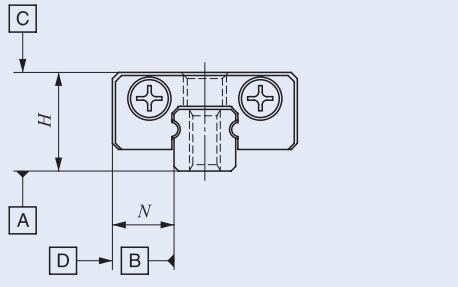

Item	Classification (Symbol)	
	High (H)	Precision (P)
Dim. H tolerance	± 0.020	± 0.010
Dim. N tolerance	± 0.025	± 0.015
Dim. Variation of H (1)	0.015	0.007
Dim. Variation of N (1)	0.020	0.010
Parallelism in operation of C to A	See Fig.1	
Parallelism in operation of D to B	See Fig.1	

unit: mm

Note(1): It means the size variation between slide units mounted on the same track rail.

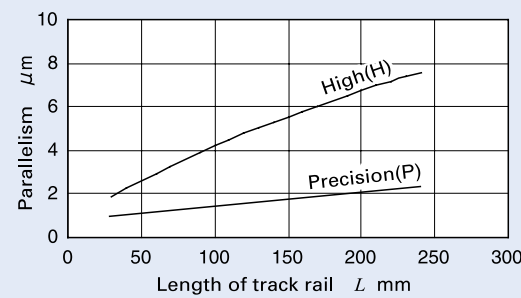

Fig. 1 Parallelism in operation of Micro Linear Way LWL (Size 2 or larger)

Special Specifications

Micro Linear Way LWL series with the special specifications shown in Table 4 are optionally available for various applications. When ordering, add any supplemental codes onto the identification number. If a combination of special specifications is required (See Table 5), indicate the supplemental codes in alphabetical order. These optional items can be combined to achieve further improvements in performance. These special specifications are not available to size 1.

Table 4 Applicable specifications

Specifications	Supplemental code
With stainless steel end plate (1)	/BS
Opposite reference surface arrangement	/D
Specified rail mounting hole positions	/E
Appending inspection sheet	/I
Without track rail mounting bolts (1)	/MN
Matched sets to be used as an assembled group	/W
Specified grease	/Y

Note(1): Applicable to size 2 and 3.
 (2): Applicable to size 4 and 6.
 (3): In size 2 and 4, only /YNG can be chosen.

Table 5 Combination of special specifications

D	○					
E	○	—				
I	○	○	○			
MN	○	○	○	○		
W	○	○	—	○	○	
Y	○	○	○	○	○	○
	BS	D	E	I	MN	W

Remark: In the table, the mark ○ indicates that this combination can be made.

With stainless steel end plates /BS

The standard synthetic resin end plates are replaced to stainless material, keeping the total length of slide unit unchanged. This specification (for size 2 and 3) is recommended for high temperature and vacuum conditions.

Opposite reference surfaces arrangement /D

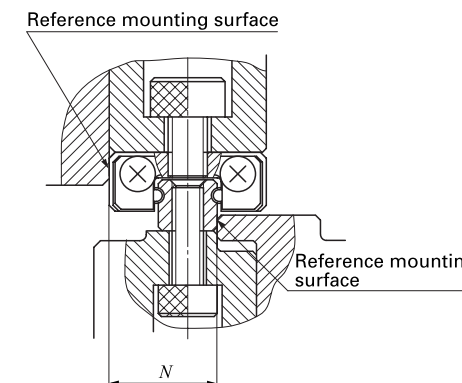

The reference mounting surface of track rail is made opposite to the standard side. The accuracy of dimension N including parallelism in operation is the same with that of standard specification.

Specified track rail mounting hole positions /E

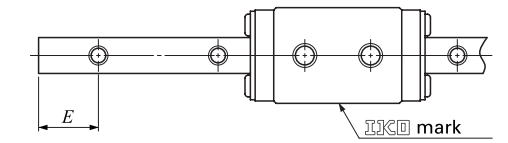

The mounting hole positions of track rail can be specified by specifying dimension E at the left end, which is the distance from the mounting hole nearest to the left end of the track rail to the left end face of the track rail in sight of IKCO mark on the slide unit. When ordering, add the dimension (in mm) after "/E". Dimension E can be specified in a limited range. Consult IKCO for further information.

With inspection sheet /I

The inspection sheet recording dimensions H and N (See "Accuracy"), dimensional variations of H and N , and parallelism in operation of the slide unit is attached to each set.

Without track rail mounting bolts /MN

Track rail mounting bolts are not appended. (Applicable to sizes 4 and 6)

Matched sets to be used as an assembled group /W

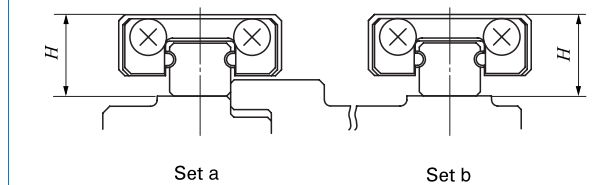

For two or more sets of Micro Linear Way LWL used on the same plane, the dimensional variation of H of Micro Linear Way LWL is kept within the specified range. The dimensional variation of dimension H in matched sets in the same as that of single set. Indicate the number of sets after "/W".

Specified grease /YCG /YCL /YBR /YNG

The type of pre-packed grease in the slide unit can be changed by a supplemental code.

- ① /YCG Low Dust Generation Grease for Clean Environment CG2 is pre-packed.
- ② /YCL Low Dust Generation Grease for Clean Environment CGL is pre-packed.
- ③ /YBR MOLYKOTE BR-2 PLUS Grease (Dow Corning) is pre-packed.
- ④ /YNG No grease is pre-packed.

Note: For sizes 2 and 4, only /YNG is applicable.

1N=0.102kgf=0.2248lbs.
 1mm=0.03937inch

Load Rating and Life

Basic dynamic load rating C

The basic dynamic load rating is defined as a constant load both in direction and magnitude under which a group of identical Micro Linear Way LWL series are individually operated and 90% of those in the group can travel 50×10^3 m free from material damage due to rolling contact fatigue.

Basic static load rating C_0

The basic static load rating is defined as a static load that gives a prescribed constant contact stress at the center of the contact area between rolling elements and raceways receiving the maximum load.

It is the allowable limit load that permits normal rolling motion. Generally, the basic static load rating is used in combination with the static safety factor.

Static moment rating T_0, T_X, T_Y

The static moment rating is defined as a static moment load (See Fig.3) that gives a prescribed constant contact stress at the center of the contact area between rolling elements and raceways receiving the maximum load.

The static moment rating is used in combination with the static safety factor to give the limiting load for normal rolling motion.

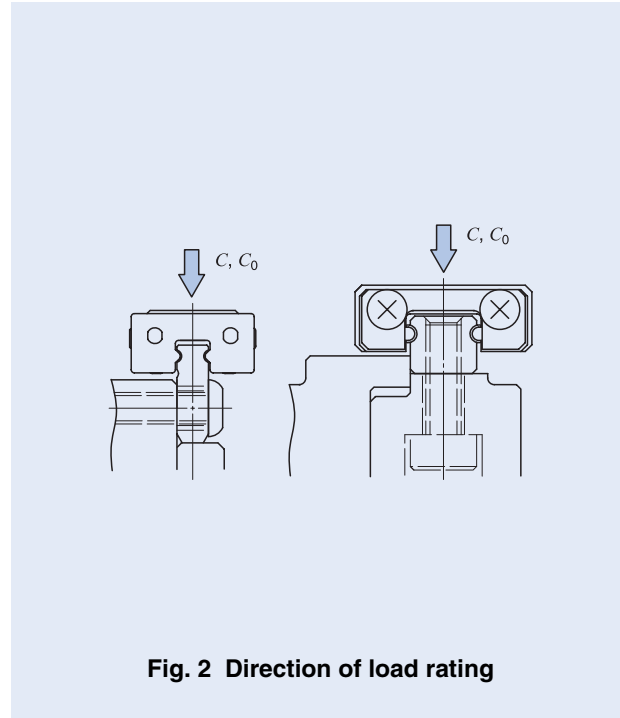

Fig. 2 Direction of load rating

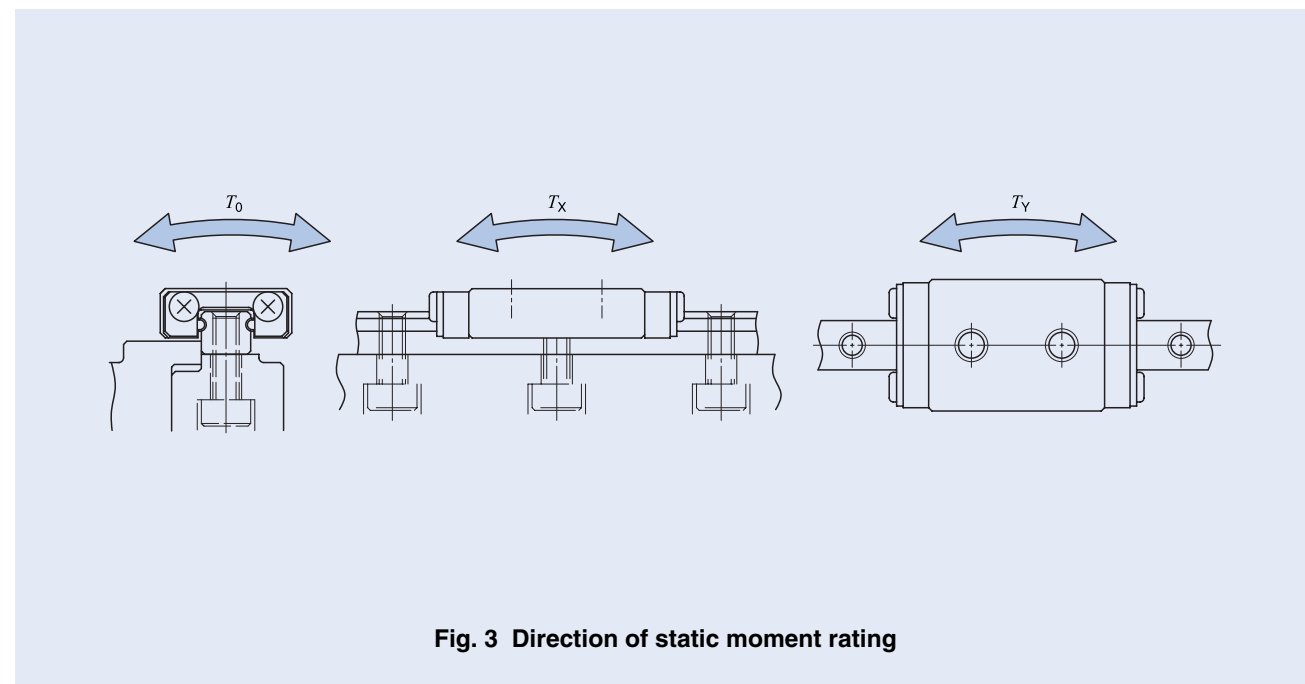

Fig. 3 Direction of static moment rating

Life

The rating life of Micro Linear Way LWL series is obtained from the following calculation formula.

$$L = 50 \left(\frac{C}{P} \right)^3 \dots\dots\dots (1)$$

where, L : Rating life, 10^3 m
 C : Basic dynamic load rating, N
 P : Dynamic equivalent load, N

If the stroke length and the number of strokes per minute are known, the life in hours must be calculated by the following formula.

$$L_h = \frac{10^6 L}{2Sn_1 \times 60} \dots\dots\dots (2)$$

where, L_h : Rating life in hours, hours
 S : Stroke length mm
 n_1 : Number of strokes per minute cpm

Static safety factor

The static safety factor f_s of Micro Linear Way LWL is given in the following formula, and general values of this factor are shown in Table 6.

$$f_s = \frac{C_0}{P_0} \dots\dots\dots (3)$$

where, f_s : Static safety factor
 C_0 : Basic static load rating, N
 P_0 : Static equivalent load, N

Table 6 Static safety factor

Operating conditions	f_s
Operation with vibration and/or shocks	3 ~ 5
High operating performance	2 ~ 4
Normal operation	1 ~ 3

Load factor

Actual loads applied to the linear motion rolling guide sometimes exceed the theoretically calculated load due to vibration and shocks caused by machine operation. The actual life is calculated by multiplying the theoretical load by the load factor indicated in Table 7.

Table 7 Load factor

Conditions	f_w
Smooth operation free from vibration and/or shocks	1 ~ 1.2
Normal operation	1.2 ~ 1.5
Operation with shock loads	1.5 ~ 3

Dynamic equivalent load for rating life

When a load is applied in a direction other than that of the basic dynamic load rating of Linear Way or a complex load is applied, the dynamic equivalent load must be calculated to obtain the basic rating life. Obtain the downward and lateral conversion loads from the loads and moments in various directions.

$$F_{re} = k_r |F_r| + \frac{C_0}{T_0} |M_0| + \frac{C_0}{T_X} |M_X| \dots\dots\dots (4)$$

$$F_{ae} = k_a |F_a| + \frac{C_0}{T_Y} |M_Y| \dots\dots\dots (5)$$

where, F_{re} : Downward conversion load, N
 F_{ae} : Lateral conversion load, N
 F_r : Downward load, N
 F_a : Lateral load, N
 M_0 : T_0 moment, N·m
 M_X : T_X moment, N·m
 M_Y : T_Y moment, N·m
 k_r, k_a : Conversion factor by load direction (See Table 8)
 C_0 : Basic static load rating, N
 T_0 : T_0 static moment, N·m
 T_X : T_X static moment, N·m
 T_Y : T_Y static moment, N·m

Table 8 Conversion factor by load direction

Condition	Conversion factor	
	k_r	k_a
$F_r \geq 0$	1	0.84
$F_r < 0$	1	

From the converted downward and lateral load, mean equivalent dynamic load must be corrected by the following formula.

$$P = XF_{re} + YF_{ae} \dots\dots\dots (6)$$

where, P : Mean equivalent dynamic load, N
 X, Y : Mean equivalent dynamic load factor (See Table 9)

F_{re} : Converted downward load, N
 F_{ae} : Converted lateral load, N

Table 9 Mean equivalent dynamic load factor

Condition	X	Y
$ F_{re} \geq F_{ae} $	1	0.6
$ F_{re} < F_{ae} $	0.6	1

Lubrication and Dust Protection

Static equivalent load for static safety factor

When a load is applied in a direction other than that of the basic static load rating of Linear Way or a complex load is applied, the static equivalent load must be calculated to obtain the static safety factor.

From each directional load, converted load equal to downward or lateral is given by following formula.

$$P_0 = k_{0r}|F_r| + k_{0a}|F_a| + \frac{C_0}{T_0}|M_0| + \frac{C_0}{T_X}|M_X| + \frac{C_0}{T_Y}|M_Y| \quad \dots(7)$$

where, P_0 : Static equivalent load, N

F_r : Downward load, N

F_a : Lateral load, N

M_0 : T_0 moment, N·m

M_X : T_X moment, N·m

M_Y : T_Y moment, N·m

k_{0r}, k_{0a} : Conversion factor by load direction

(See Table 10)

C_0 : Basic static load rating, N

T_0 : T_0 static moment, N·m

T_X : T_X static moment, N·m

T_Y : T_Y static moment, N·m

Table 10 Conversion factor by load direction

Condition	Conversion factor	
	k_{0r}	k_{0a}
$F_r \geq 0$	1	0.84
$F_r < 0$	1	

Quality lithium-soap base grease (MULTEMP PS No.2: KYODO YUSHI) is pre-packed in Micro Linear Way LWL.

The quality of any grease will gradually deteriorate as operating time passes. Therefore, periodic re-lubrication is necessary. The re-lubrication interval varies depending on the operating conditions of the rolling guides. A six months interval of generally recommended and, if the machine operation consists of reciprocating motions with many cycles and long strokes, re-lubrication every three months is recommended.

Micro Linear Way LWL does not have oil hole thus, grease must be directly applied on the raceways of track rail. Miniature Grease Injector is available and please consult  if necessary.

After grease is replenished, running in is performed and excess grease will be discharged from the inside of rolling guide. Discharged grease must then be removed before starting the operation. Low and stable friction can be obtained after ten to twenty times of manual strokes. It is possible to reduce the amount of grease to make frictional resistance lower. But careful attention is necessary to keep minimum amount of lubricant strictly for the product safety.

Micro Linear Way LWL does not have end seals. When it is used in places except clean environment, preparing dust protection cover is recommended to avoid intruding harmful dust and particles from outside.

Precautions for Use

① Mounting surface, reference mounting surface, and general mounting structure

To mount Micro Linear Way LWL, correctly fit the reference mounting surfaces B and D (D_1 or D_2) of the slide unit and track rail to the reference mounting surfaces of the table and the bed, and then fix them tightly. (See Fig.4.3)

In size 1, reference surfaces are available to both side of slide unit. (D_1 and D_2)



Track rail of LWL1-Y can be mounted in lateral direction.

Two kinds of mounting methods can be chosen. (See Fig.4.1 and 4.2)

The reference mounting surfaces B and D (D_1 and D_2) and the mounting surfaces A and C of Micro Linear Way LWL are accurately finished by grinding. Stable and high accuracy linear motion can be obtained by finishing the mating mounting surfaces of machines or equipment with high accuracy and correctly mounting the guide on these surfaces.

Reference mounting surfaces of slide unit and track rail are shown in Table 11.

Table 11 Reference mounting surface of slide unit and track rail

Model number	Slide unit	Track rail
LWL1	Either side is possible. (See Fig.5.1)	—
LWL1...Y	—	Opposite to  mark. (See Fig.5.1)
LWL2 or larger	Opposite to  mark. (See Fig.5.2)	Side surface above the  mark (in the direction of the arrow. See Fig.5.2)

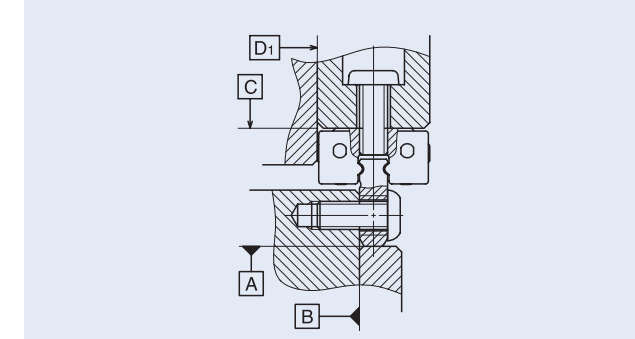

Fig. 4.2 Reference mounting surface and general mounting structure II of LWL1...Y

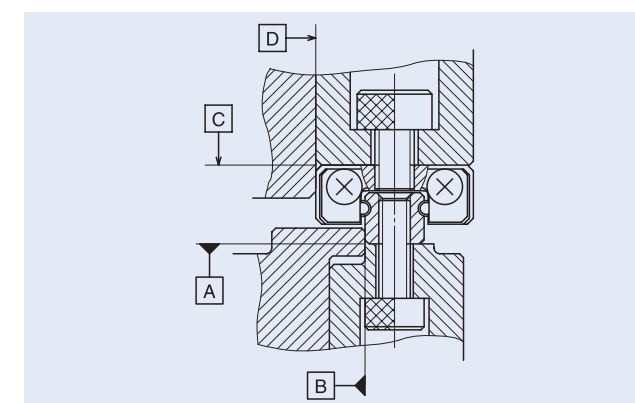

Fig. 4.3 Reference mounting surface and general mounting structure of LWL2 or larger

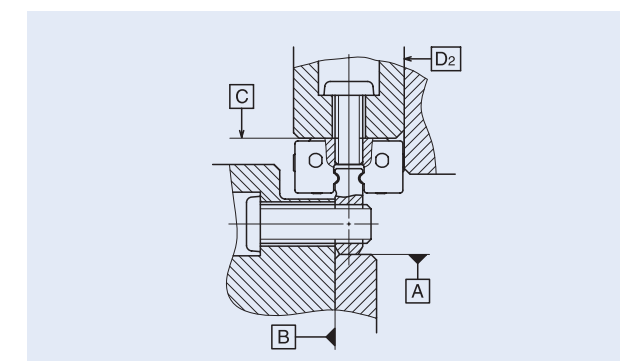

Fig. 4.1 Reference mounting surface and general mounting structure I of LWL1...Y

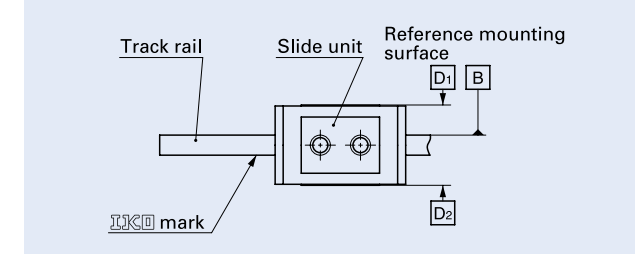

Fig. 5.1 Reference mounting surface of LWL1

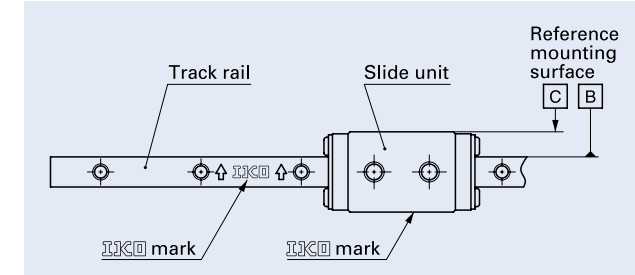

Fig. 5.2 Reference mounting surface of LWL2 or larger

② Female threads for mounting the slide unit and track rail are through holes.

If the fixing depth of the mounting bolts is too long, the bolts will interfere with the slide unit or track rail, resulting in poor traveling accuracy and short life. The fixing depth of the mounting bolts should be kept within the values shown in the table of dimensions. Also, small head (less than 1.8mm) screw for precision equipment is recommended for mounting of size 1.

③ The mounting bolts for track rail are not appended.

For sizes 2 and 3, prepare bolts with a fixing depth not exceeding H4 shown in the dimension table.

④ Corner radius and shoulder height of reference mounting surfaces

It is recommended to make a relieved fillet at the corner of the mating reference mounting surface as shown in Fig.4.1 and Fig. 4.2.

Table 12 and Table 13 show recommended shoulder height and radius of the reference mounting surfaces.

Table 12 Shoulder height for the reference mounting surface of slide unit

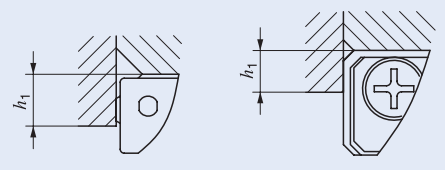

unit: mm

Model number	Shoulder height for slide unit h_1
LWL 1	1.3
LWL 2	1
LWLC 3, LWL 3	1.2
LWLF 4	1.5
LWLFC 6, LWLF 6	2

Table 13 Shoulder height for the reference mounting surface of track rail

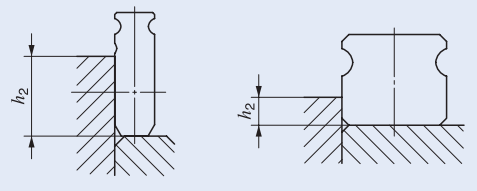

unit: mm

Model number	Shoulder height for track rail h_2
LWL 1...Y	2
LWL 2	0.5
LWLC 3, LWL 3	0.8
LWLF 4	0.8
LWLFC 6, LWLF 6	0.8

Remark: For LWL1, prepare the reference mounting surface not to interfere with slide unit.

⑤ Multiple slide units mounted in close distance

When using multiple slide units in close distance to each other, actual load may be greater than the calculated load depending on the mounting accuracy of the slide units on the mounting surfaces and the reference mounting surfaces of the machines. It is suggested in such cases to assume a greater load than the calculated load.

⑥ Operating temperature

The maximum operating temperature is 120°C and a continuous operation is possible at temperatures up to 100°C. When the temperature exceeds 100°C, consult .

Mounting

① When assembling two or more sets

Use an assembly of slide unit and track rail as delivered without changing the combination.

Matched sets to be used as an assembled group
Special specification products of matched sets (by supplemental code"/W") are delivered as a group in which dimensional variations are specially controlled. Mount them without mixing with the sets of another group.

② Assembling a slide unit and a track rail

When assembling Micro Linear Way LWL, correctly fit the groove of the slide unit mounted on a steel ball holder to the groove of the track rail, and then move the slide unit gently from the steel ball holder to the track rail in parallel direction. Steel balls are not retained in Micro Linear Way, so using steel ball holder is necessary when re-assemble the slide unit from the track rail.

For sizes 2 or larger, a steel ball holder is appended as an accessory.

③ Cleaning the mounting surfaces

When mounting Micro Linear Way LWL, first clean all mounting and reference mounting surfaces. (See Fig.7)

Remove burrs and blemishes from the reference mounting surfaces and mounting surfaces of the machine using an oil-stone, etc., and then wipe the surfaces with clean cloth.

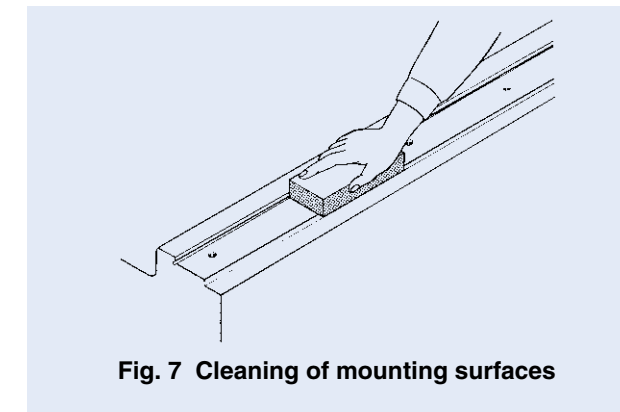

Fig. 7 Cleaning of mounting surfaces

④ Tightening torque of mounting bolts

The standard torque values for Micro Linear Way mounting bolts are shown in Table 14. When machines or equipment are subjected to serve vibration, shock, large fluctuating load, or moment load, the bolts should be tightened with a torque 1.2 to 1.5 times higher than the standard torque values shown. When the mating member material is cast iron or aluminum, tightening torque should be lowered in accordance with strength characteristics of the material.

Table 14 Tightening torque of mounting bolts

Bolt size	Tightening torque N-m
	Stainless steel bolt (Property division A2-70)
M1 × 0.25	0.04
M1.4 × 0.3	0.10
M1.6 × 0.35	0.15
M2 × 0.4	0.31

Remark: Tightening torque for LWL1 is recommended to be 70 to 80% of the values in the table.

Track Rail Lengths

Standard and maximum lengths of track rails of Micro Linear Way LWL are shown in Table 15.

Track rail in any length are also available. Simply indicate the necessary length of track rail in millimeter (mm) in the identification number.

E-dimensions at both ends are the same unless otherwise specified. To change these dimensions, specify the specified rail mounting hole positions (supplemental code "/E") of special specification.

Table 15 Standard and maximum lengths of track rail

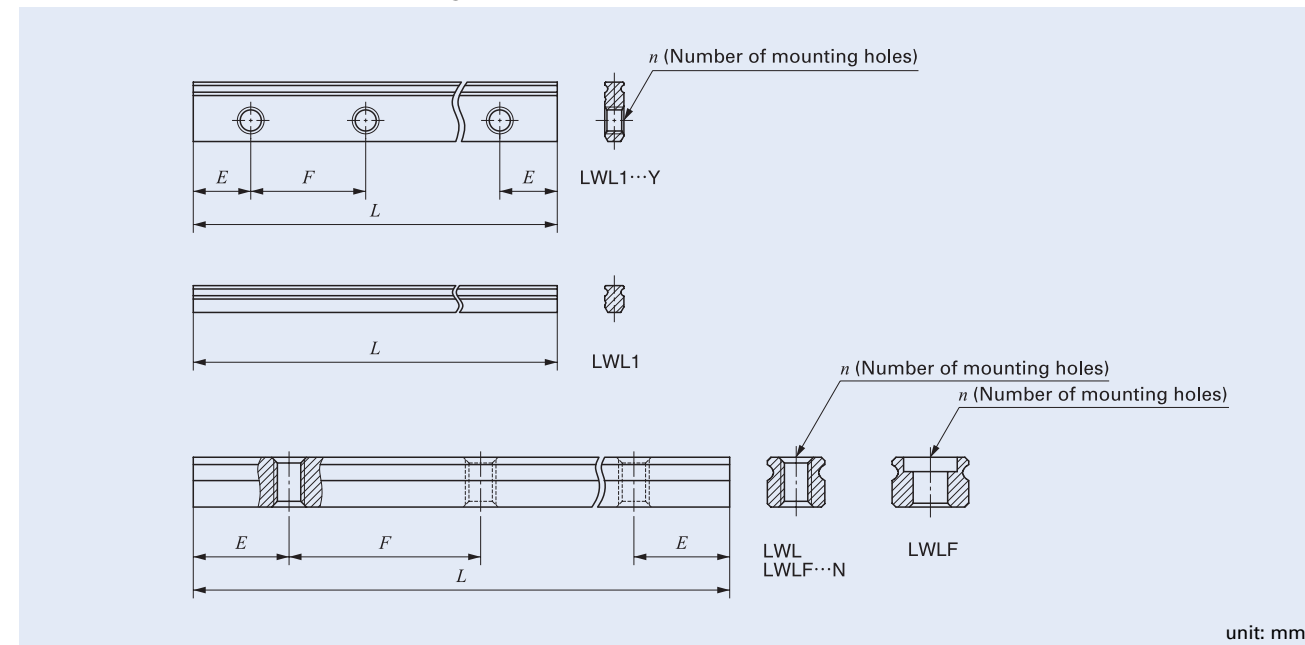

Model number		LWL 1...Y	LWL 1	LWL 2	LWL 3	LWLF 4	LWLF 6
Standard length $L(n)$		18(3)	18(-)	32(4)	30(3)	40(4)	60(4)
		30(5)	30(-)	40(5)	40(4)	60(6)	90(6)
		42(7)	42(-)	56(7)	60(6)	70(7)	105(7)
Mounting hole pitch F		6	—	8	10	10	15
E		3	—	4	5	5	7.5
Standard range of E	Over (Incl.)	2.5	—	2.5	3	3.5	4.5
	Under	5.5	—	6.5	8	8.5	12
Maximum length ⁽¹⁾		102	102	104 (200)	150 (300)	180 (300)	240 (300)

Note⁽¹⁾: The track rails can be manufactured up to the maximum length shown in parentheses. If required, please consult .
Remarks: The above table shows representative model numbers but is applicable to all models of the same size.

Mounting Bolts

For Micro Linear Way LWL, fixing bolts for slide unit and tapped track rail are available as shown in Table 16.1 and Table 16.2. Consult .

Table 16.1 Cross-recessed head cap screw for precision equipment

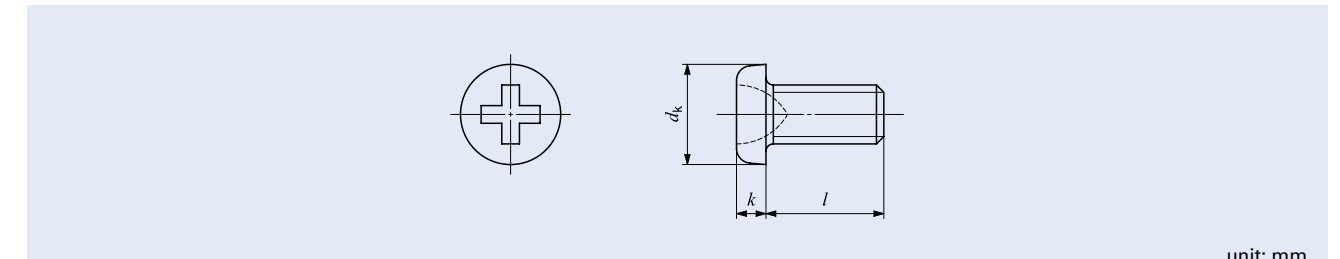

Nominal size d	Pitch of screw P	Boundary dimension		
		d_k	k	l
M1	0.25	1.8	0.45	3, 4, 5
M1.4	0.3	2.5	0.8	2.5, 3, 4
M1.6	0.35	2.8	0.85	4, 5, 6
M2	0.4	3.5	1	3, 4, 5

Remark: They differ from appended track rail mounting bolt.

Table 16.2 Hexagon socket head bolt

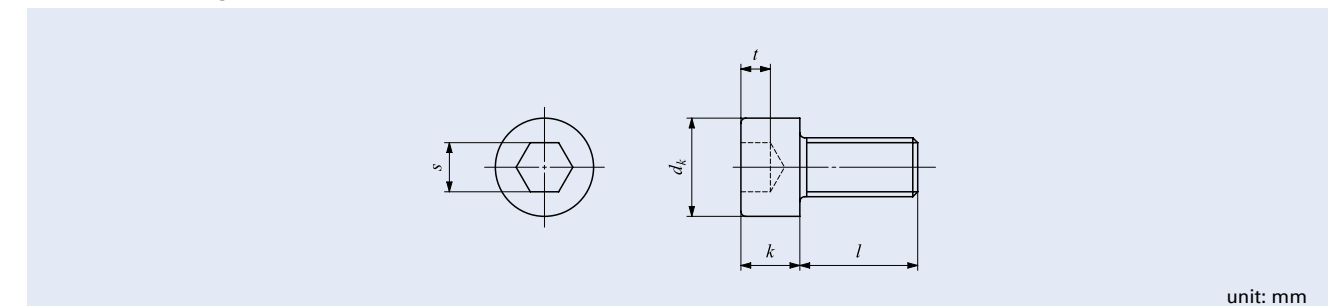

Nominal size d	Pitch of screw P	Boundary dimension				
		d_k	k	s	t	l
M1.4	0.3	2.6	1.4	1.3	0.6	2.5, 3, 4
M1.6 ⁽¹⁾	0.35	3	1.6	1.5	0.7	4, 5, 6
M2 ⁽¹⁾	0.4	3.8	2	1.5	1	3, 4, 5

Note⁽¹⁾: They conform to JIS 1176. (Japanese Industrial Standard)

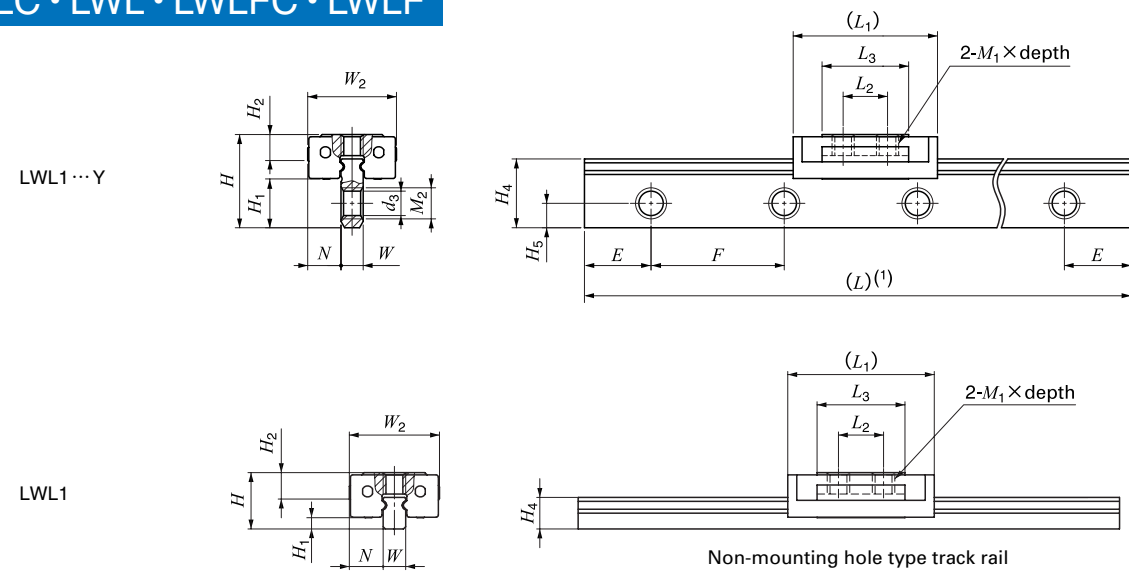

LWL 2
LWLC 3
LWL 3

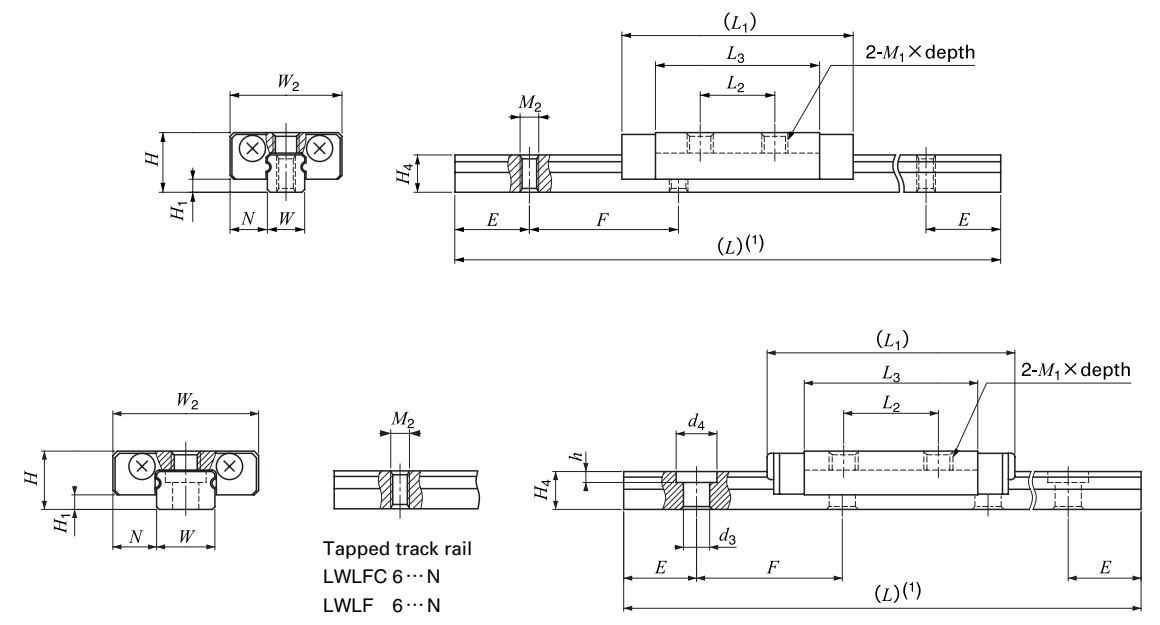

Model number	Mass (Reference) g		Dimension of assembly mm			Dimension of slide unit mm								
	Slide unit	Track rail (per 100mm)	H	H ₁	N	W ₂	L ₁	L ₂	L ₃	M ₁ × depth	H ₂	W	H ₄	H ₅
LWL 1...Y	0.16	2.1	4.2	2.2	1.5	4	6.5	2	3.9	M1 × 0.9	1.2	1	3.1	1.1
LWL 1		1.0	2.5	0.5									1.4	—
LWL 2	0.9	2.8	3.2	0.7	2	6	12.4	4	8.8	M1.4 × 1.4	—	2	2	—
LWLC 3	1.0	5.3	4	1	2.5	8	12	3.5	6.7	M1.6 × 1.3	—	2.6	2.6	—
LWL 3							16	5.5	10.7					
LWLF 4	2.1	6.8	4	1	3	10	17	6.5	11.9	M2 × 1.3	—	2.6	2.6	—
LWLF 6	2.4	13	4.5	1	3	12	15	4.5	9.8	M2 × 1.6	—	2.8	2.8	—
LWLF 6...N		12					20	8	14.6					
LWLF 6	3.4	13	4.5	1	3	12	20	8	14.6	M2 × 1.6	—	2.8	2.8	—
LWLF 6...N		12												

Dimension of track rail mm						Appended mounting bolt for track rail mm Bolt size × length	Basic dynamic load rating ⁽⁴⁾ C	Basic static load rating ⁽⁴⁾ C ₀	Static moment rating			Model number	
M ₂	d ₃	d ₄	h	E	F				T ₀	T _X	T _Y		
						N			N · m	N · m	N · m		
M1.4 Through	1.1	—	—	3	6	M1 × ℓ or M1.4 × ℓ ⁽²⁾ (Not appended)	66.8	113	0.06	0.07	0.09	LWL 1...Y	
—	—	—	—	—	—	—						0.47	0.56
M1 Through	—	—	—	4	8	M1 × ℓ ⁽³⁾ (Not appended)	211	381	0.42	0.54	2.9	0.64	LWL 2
M1.6 Through	—	—	—	5	10	M1.6 × ℓ ⁽³⁾ (Not appended)							251
—	1.8	2.8	0.75	5	10	Cross-recessed head screw for precision equipment M1.6 × 5	390	677	1.4	1.3	7.1	1.5	LWLF 4
—	2.4	4	1.5	7.5	10	Cross-recessed head screw for precision equipment M2 × 4							334
M3 Through	—	—	—				7.5	10	Cross-recessed head screw for precision equipment M2 × 4	443	813	2.5	1.8
—	2.4	4	1.5	LWLF 6									
M3 Through	—	—	—	—	—	—	—	—	—	—	—	—	LWLF 6...N

Note⁽¹⁾: Track rail lengths L are shown in Table 15.
⁽²⁾: Bolt is required suit to mounting structure.
⁽³⁾: Prepare track rail mounting bolts with a fixing depth less than H₄.
⁽⁴⁾: The directions of basic dynamic load rating (C), basic static load rating (C₀) and static moment rating (T₀, T_X and T_Y) are shown in the sketches below. The upper values in the T_X and T_Y column apply to one slide unit, and the lower values apply to two units in close contact.
 Remarks: 1. Steel parts are made of stainless steel.
 2. Steel balls are not retained. End seals are not attached.
 3. For LWLF4, LWLF6 and LWLF6, stainless cross-recessed head screw for precision equipment is appended for fixing track rail. Please indicate supplemental code /MN if unnecessary.

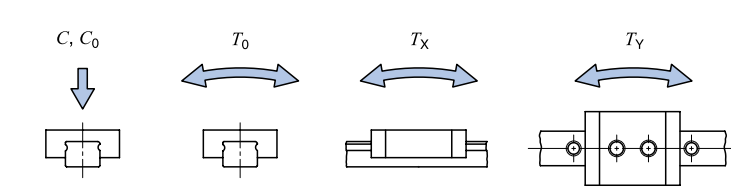

Example of identification number for assembled set

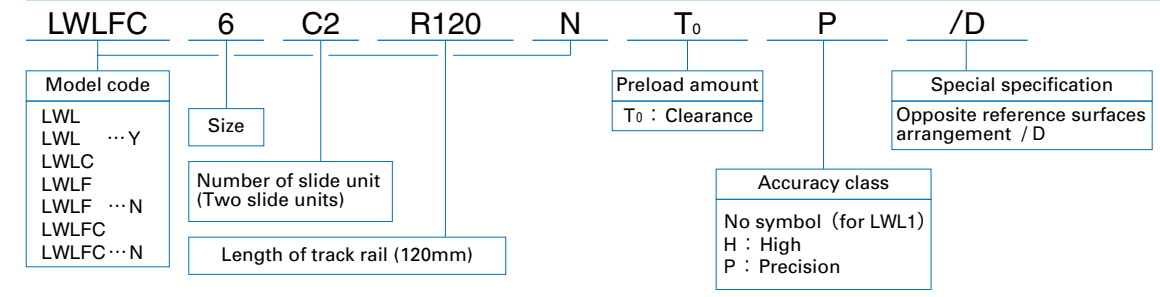

Unprecedented smoothness and for Saving energy

compactness and Compact designing

IKO Stroke Ball Spline

CAT-57155

LS

This is our new output for the manufacturing process of semiconductor and liquid crystal display requires high speed and high acceleration. As a regular leader of this industrial field.....

Unprecedented smoothness

Precise ball retainer is incorporated and non-circulation structure provide superior low friction even in the vertical operation.

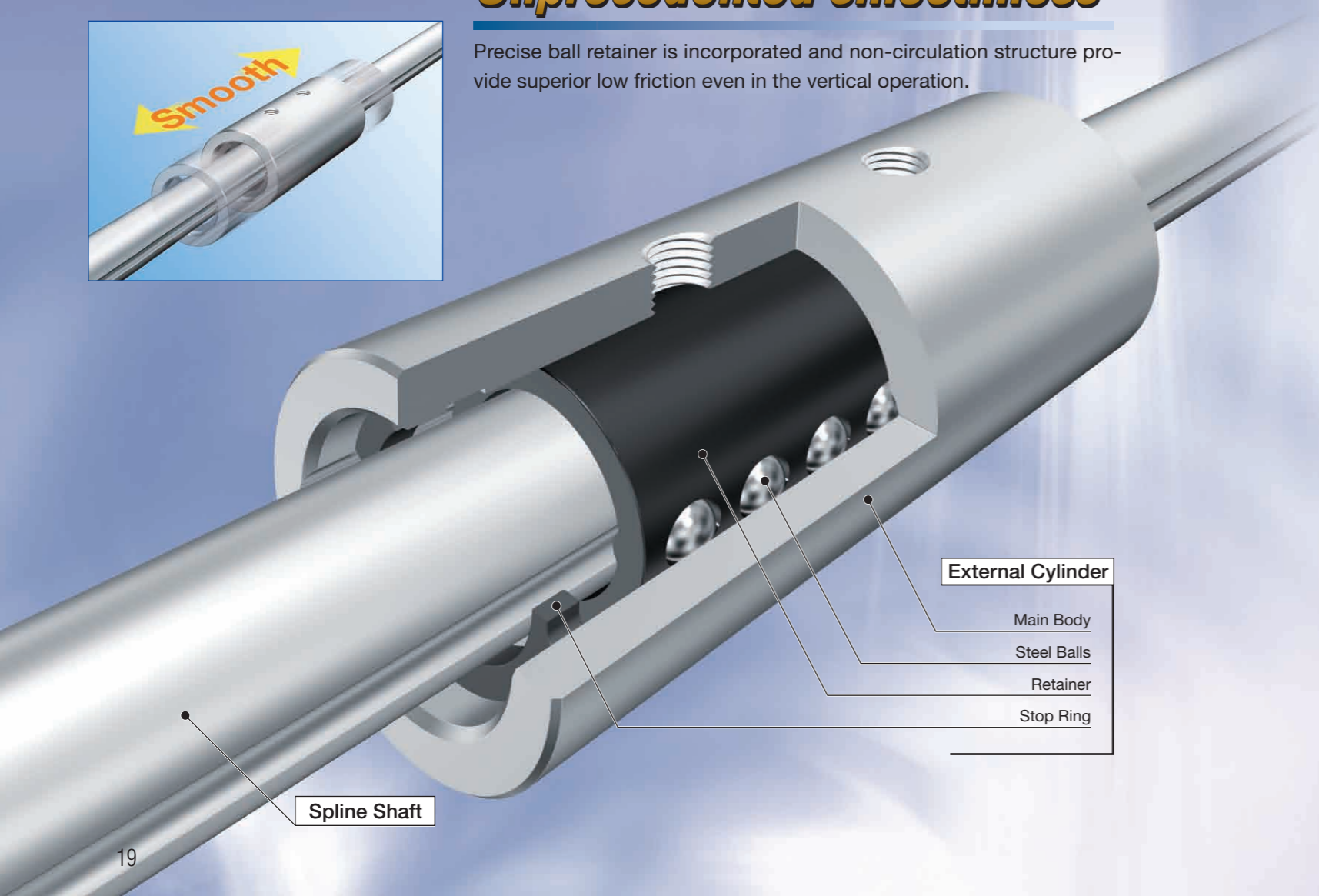

External Cylinder

Main Body

Steel Balls

Retainer

Stop Ring

Spline Shaft



Compact design with high rigidity

Large diameter steel balls are arranged in two rows and in four point contact with the raceways, achieving compact design with high rigidity under any direction of load and moment.

Superior positioning accuracy

By applying suitable preload, clearance in the rotational direction is eliminated. So high positioning accuracy in the rotational direction has been obtained.

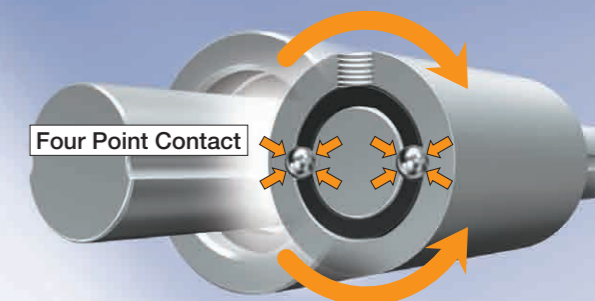
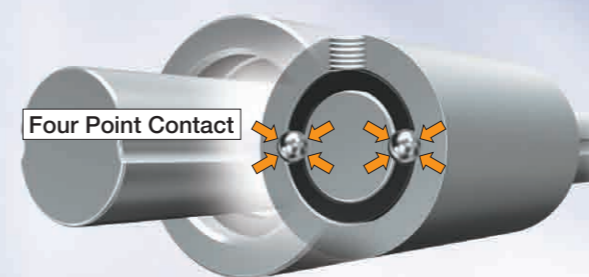

Stroke Ball Spline LS
(Limited Stroke Length)

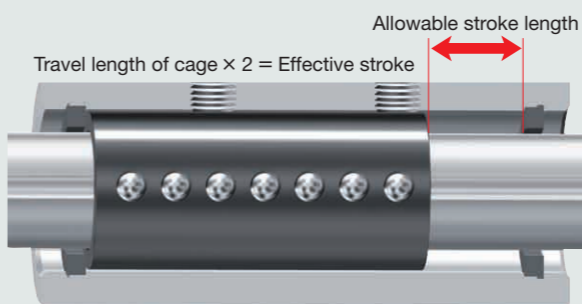

Available shaft diameter: 4mm to 6mm

Linear Ball Spline G LSAG
(Unlimited Stroke Length)

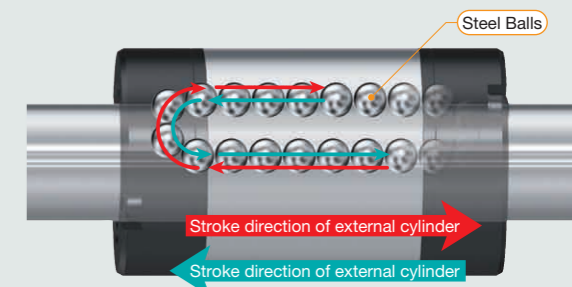

Available shaft diameter: 2mm to 50mm

World Network of **IKO**

NIPPON THOMPSON CO., LTD.

Head office : 19-19 Takanawa 2-chome Minato-ku
Tokyo 108-8586, Japan
Phone : +81 (0)3-3448-5850
Fax : +81 (0)3-3447-7637
E-mail : ntt@ikonet.co.jp
URL : <http://www.ikont.co.jp/eg/>
Plant : Gifu, Kamakura

NIPPON THOMPSON CO., LTD.

ASEAN REPRESENTATIVE OFFICE

Level 8, #1 Silom Road, Silom
Bangrak, Bangkok
Thailand 10500
Phone: +66 (0)-2-231-8278
Fax: +66 (0)-2-231-8121
E-mail: ntar@ikonet.co.jp

IKO-THOMPSON (SHANGHAI) LTD.

Unit G, 23rd Floor, Zhao Feng World Trade Building
No.369, Jiang Su Road
Changning District, Shanghai 200050
People's Republic of China
Phone: +86 (0)21-5237-9100
Fax: +86 (0)21-5237-9095
E-mail: ntc@ikonet.co.jp

IKO INTERNATIONAL, INC.

<http://www.ikont.com/>

East coast

91 Walsh Drive
Parsippany, NJ 07054
U.S.A.
Phone: +1 973-402-0254
Toll Free: 1-800-922-0337
Fax: +1 973-402-0441
E-mail: eco@ikonet.co.jp

Midwest

500 East Thorndale Avenue
Wood Dale, IL 60191
U.S.A.
Phone: +1 630-766-6464
Toll Free: 1-800-323-6694
Fax: +1 630-766-6869
E-mail: mwo@ikonet.co.jp

West coast

20170 South Western Avenue
Torrance, CA 90501
U.S.A.
Phone: +1 310-609-3988
Toll Free: 1-800-252-3665
Fax: +1 310-609-3916
E-mail: wco@ikonet.co.jp

Southeast

2150 Boggs Road, Suite 100
Duluth, GA 30096
U.S.A.
Phone: +1 770-418-1904
Toll Free: 1-800-874-6445
Fax: +1 770-418-9403
E-mail: seo@ikonet.co.jp

Southwest

8105 N. Beltline Road
Suite 130, Irving, TX 75063
U.S.A.
Phone: +1 972-929-1515
Toll Free: 1-800-295-7886
Fax: +1 972-915-0060
E-mail: swo@ikonet.co.jp

NIPPON THOMPSON EUROPE B.V.

<http://www.ikont.eu/>

The Netherlands

Sheffieldstraat 35-39
3047 AN Rotterdam
The Netherlands
Phone: +31 (0)10-4626868
Fax: +31 (0)10-4626099
E-mail: nte@ikonet.co.jp

Germany

Mündelheimer Weg 56
40472 Düsseldorf
Germany
Phone: +49 (0)211-414061
Fax: +49 (0)211-427693
E-mail: ntd@ikonet.co.jp

Im Gewerbepark D 30
93059 Regensburg
Germany
Phone: +49 (0)941-206070
Fax: +49 (0)941-2060719
E-mail: ntdr@iko-nt.de

Gruben Str.95c
66540 Neunkirchen
Germany
Phone: +49 (0)6821-999-860
Fax: +49 (0)6821-999-8626
E-mail: ntdn@iko-nt.de

UK

2 Vincent Avenue, Crownhill
Milton Keynes Bucks MK8 0AB
United Kingdom
Phone: +44 (0)1908-566144
Fax: +44 (0)1908-565458
E-mail: sales@iko.co.uk

Spain

Autovia Madrid-Barcelona, Km. 43,700
Polig. Ind. AIDA, A-8, Ofic. 2, 1^a
19200-Azuqueca de Henares
Guadalajara, Spain
Phone: +34 949-263390
Fax: +34 949-263113
E-mail: nts@ikonet.co.jp

France

Roissypole Le Dôme
2 rue de La Haye
BP 15950 Tremblay en France
95733 Roissy C. D. G. Cedex
France
Phone: +33 (0)1-48165739
Fax: +33 (0)1-48165746
E-mail: ntf@ikonet.co.jp

Recognizing that conservation of the global environment is the top-priority challenge for the world's population, **I&K** will conduct its activities with consideration of the environment as a corporate social responsibility, reduce its negative impact on the environment, and help foster a rich global environment.

**ISO 9001 & 14001 Quality system
registration certificate**

