



Disc

In This Section:

- SU-6 Series
- SX-6 Series
- SX-8 Series
- SXC-6 Series
- SXCS-6 Series
- SXCST-6 Series
- DI-6 Series
- DI-8 Series
- DIR-6 / DILR-6 Series
- DIRA-6 / DILRA-6 Series





Disc

Safety Warning

When using Lovejoy products, you must follow these instructions and take the following precautions. Failure to do so may cause the power transmission product to break and parts to be thrown with sufficient force to cause severe injury or death.

Refer to this Lovejoy Catalog for proper selection, sizing, horsepower, torque range, and speed range of power transmission products, including elastomeric elements for couplings. Follow the installation instructions included with the product, and in the individual product catalogs for proper installation of power transmission products. Do not exceed catalog ratings.

During start up and operation of power transmission product, avoid sudden shock loads. Coupling assembly should operate quietly and smoothly. If coupling assembly vibrates or makes beating sound, shut down immediately, and recheck alignment. Shortly after initial operation and periodically thereafter, where applicable, inspect coupling assembly for: alignment, wear of elastomeric element, bolt torques, and flexing elements for signs of fatigue. Do not operate coupling assembly if alignment is improper, or where applicable, if elastomeric element is damaged, or worn to less than 75% of its original thickness.

Do not use any of these power transmission products for elevators, man lifts, or other devices that carry people. If the power transmission product fails, the lift device could fall resulting in severe injury or death.

For all power transmission products, you must install suitable guards in accordance with OSHA and American Society of Mechanical Engineers Standards. Do not start power transmission product before suitable guards are in place. Failure to properly guard these products may result in severe injury or death from personnel contacting moving parts or from parts being thrown from assembly in the event the power transmission product fails.

If you have any questions, contact the Lovejoy Engineering Department at 1-630-852-0500.



Disc

Table of Contents

	Running Page No.	Section Page No.
Overview.....	234	D-4
Selection Process.....	236	D-6
Application Service Factors > Selection Data	237	D-7
Disc Coupling Selection Worksheet	238	D-8
Specifications > Performance Data	239	D-9
SU-6 > Performance Data	240	D-10
SU-6 > Dimensional Data	241	D-11
SX-6 > Performance Data	242	D-12
SX-6 > Dimensional Data	243	D-13
SX-8 > Performance Data	244	D-14
SX-8 > Dimensional Data	245	D-15
SXC-6 > Performance Data.....	246	D-16
SXC-6 > Dimensional Data	247	D-17
SXCS-6 > Performance Data	248	D-18
SXCS-6 > Dimensional Data	249	D-19
SXCST-6 > Performance Data	250	D-20
SXCST-6 > Dimensional Data	251	D-21
DI-6 > Performance Data	252	D-22
DI-6 > Dimensional Data	253	D-23
DI-8 > Performance Data	254	D-24
DI-8 > Dimensional Data	255	D-25
DIR-6 and DILR-6 > Performance / Selection Process	256	D-26
DIRA-6 and DILRA-6 > Performance / Dimensional Data.....	257	D-27
Various Examples.....	258	D-28

Overview

Lovejoy takes great pride in being able to offer a wide variety of superior disc coupling products in models designed to meet the application needs of today's worldwide power transmission market.

Using advanced design techniques, implementation of Finite Element Analysis, and extensive testing of materials, Lovejoy has developed an innovative disc pack profile design revolutionary to traditional disc pack designs found in the market. This disc pack, which can accommodate 1/2° to 1-1/2° of angular misalignment and is used in all Lovejoy disc coupling products.

Lovejoy disc packs are manufactured using high grade stainless steel (AISI-301), ensuring high strength, high endurance to fatigue, and resistance to most environmental conditions.

Lovejoy disc couplings utilize unitized disc packs with both 6 or 8 bolt designs. The 8 bolt design can transmit greater torque than the 6 bolt design, however, it is not able to accommodate as much angular misalignment.

Lovejoy couplings can be fitted with overload bushings to protect the disc pack during momentary torsional overloads.

Lovejoy couplings are offered in a variety of configurations to fit most applications. In addition, Lovejoy's engineering department can customize a coupling to meet many special requirements such as close coupled, drop-out centers, electrically insulated, vertical mounting, and safety couplings. A notable design offered by Lovejoy is the reduced moment (DI Type) coupling that meets the anti-flail device requirements mandated in API-610 while offering a low weight and short center of gravity to bearing distance.

The design and manufacture of Lovejoy disc couplings is integrated into a certified Quality System according to ISO-9001 to fulfill the high quality requirements of Lovejoy customers.

 **WARNING**

You must refer to page D-2 (Page 232) for Important Safety Instructions and Precautions for the selection and use of these products. Failure to follow the instructions and precautions can result in severe injury or death.

Advantages of the Lovejoy Disc Coupling

- Eliminates the need for lubrication and coupling maintenance
- Coupling can be inspected without disassembly
- Condition of disc packs can be inspected with a strobe light while the machine is running
- Note: It is not recommended that couplings be operated without coupling guards.
- Easy to assess equipment misalignment
- Torsionally rigid without any backlash
- No wearing parts
- Resistance to harsh environments
- Long life when properly sized and aligned
- High power density (higher torque for a given outside diameter)
- Lovejoy supports the API-610 Standard up to 3,800 RPM
- Unitized disc packs ensure repeatability necessary for meeting the balance and piloting requirements as mandated by API-610

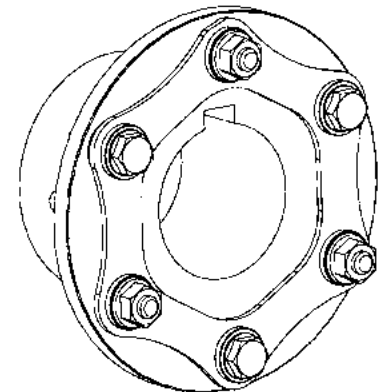

Available with Overload Bushings to protect the coupling from momentary torque overloads

- Prevents the disc pack from being plastically deformed
- Allows for shorter BSE (shaft separation) because bolts can be turned to face inward
- Special orientation of bolts allows the bolts to be tightened using a torque wrench instead of nuts (Normal is to tighten nuts with torque wrench)

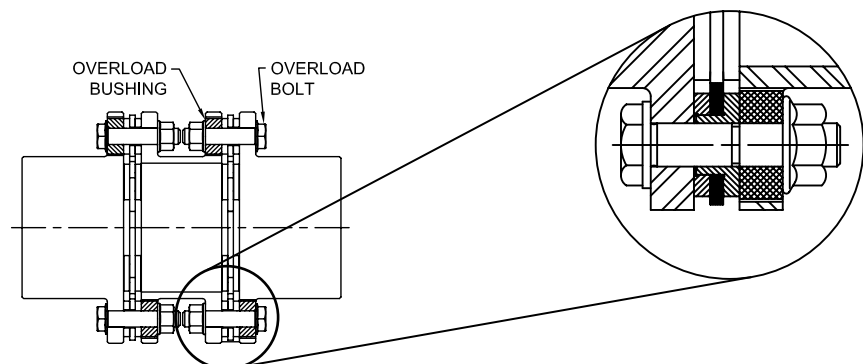

Lovejoy Disc Coupling Overview

Industrial SU Type

The SU Type coupling has a single flex plane with two hubs and a single disc pack. It is suitable for angular and axial misalignment only. Two SU couplings are often combined with a shaft to make a floating shaft coupling. The shaft can be hollow for long light weight floating shaft couplings.

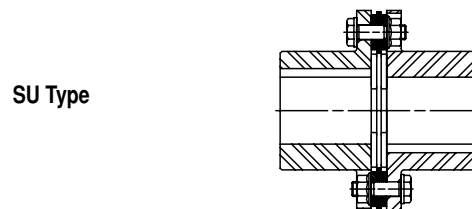

SU Type

Industrial SX Type

This is the standard coupling type that includes two hubs, a stock length spacer designed to meet industry standard lengths, and two unitized disc packs. The coupling has two flex planes, one at each disc pack, allowing this coupling to accommodate parallel, angular, and axial misalignment with specified limits. The coupling is available in 6 and 8 bolt designs and bore sizes up to 13 inches (330mm) on the largest size. Custom spacer lengths can be manufactured to meet special shaft separations required for specific applications. The SX coupling can be fitted with overload bushings to protect the disc packs in over torque conditions and can act as an anti-flail device. SX couplings are assembled at the time of installation on the equipment where the coupling will be in service.

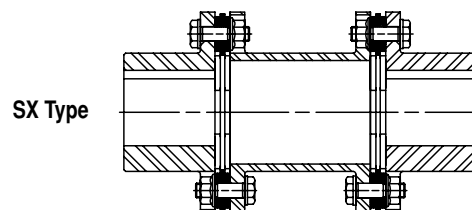

SX Type

Industrial DI Type

The DI Type coupling has a "Drop-In" spacer assembly that is assembled at the factory. The coupling consists of two hubs and a spacer assembly comprising of the spacer, two unitized disc packs, and two guard rings. The disc packs are bolted to the spacer and guard rings at the factory using the torque values recommended by Lovejoy for the disc pack bolts. With the hubs mounted on the shafts, the entire disc pack assembly can be "Dropped In" place between the two hubs. The hubs are piloted to ensure proper centering of the spacer assembly. This piloting serves as an anti-flail feature and aids in the coupling's ability to meet the balance standards mandated by API. This style coupling is designed to meet the balance and anti-flail requirements specified in API-610.

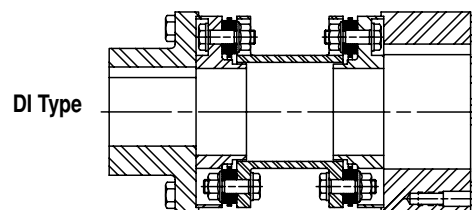

DI Type

Oversized, or Jumbo, hubs are available for use with the DI Type coupling to allow for larger bore sizes on most DI coupling sizes. This allows for the use of smaller DI couplings in applications where a smaller size coupling can still accommodate the application torque.

Industrial SXC Type

The SXC Type is the close coupled variation of the SX Type coupling. The SXC is similar to the SX coupling in that the disc packs are attached when the coupling is installed. In the close coupled units, the hubs are turned inward and are mounted inside the spacer. Note that with the hubs inside the spacer, the maximum bore allowed in the hub will be decreased. The SXC couplings can be used with one or both hubs turned outward to allow the coupling to accommodate different shaft separations.

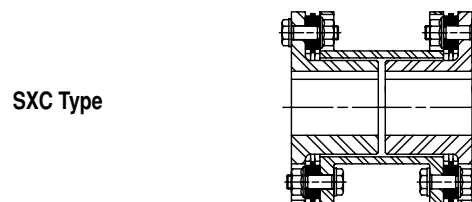

SXC Type

Industrial SXCS and SXCST Types

The SXCS and SXCST Types have split spacers and the disc packs can be serviced or removed without moving the hubs on the shafts and without moving the equipment. The SXCS Type has the bolts that connect the hubs to the split spacer installed from the ends of the couplings. The SXCST have the bolts installed from inside the spacer pointing outward towards the hubs.

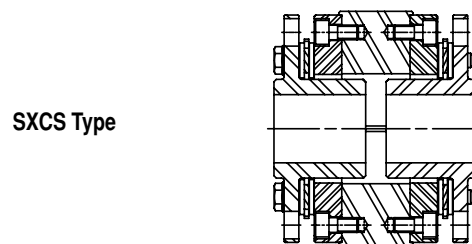

SXCS Type

Additional Types

Additional types of Lovejoy Disc couplings are illustrated on page D-28. Please contact Lovejoy Technical Support for couplings shown on these pages, or for special requirements not shown in this catalog.

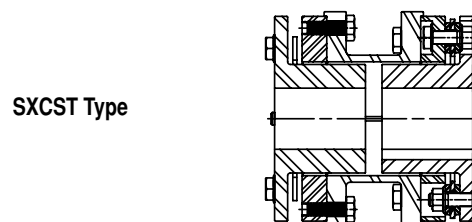

SXCST Type

Steps In Selecting A Disc Coupling

The following is a sample application used to illustrate the standard process for selecting a Lovejoy Disc coupling. Any resemblance to any existing company's application is neither intentional nor meant to resemble that company's actual application.

Sample Application:

A company has a compressor application using a 225 horsepower electric motor running at 1,150 RPM to drive a three cylinder multi stage reciprocating air compressor. The electric motor has a 3-3/8 inch shaft with a 7/8 inch keyway and the compressor has a 92mm shaft with a 25mm keyway. The shaft separation is roughly 7 inches between shaft ends with some ability to adjust the motor location. The shafts have a parallel misalignment/offset of roughly 1/32 of an inch.

Checking in the Applications Service Factors Table on Page D-7, it's noted that a three cylinder reciprocating compressor has a service factor of 3.0.

Step 1: The first step is to determine what coupling type is to be selected for this application. Since the SU Type coupling only supports a single flex plane, it can only accommodate angular and axial misalignment, but not parallel misalignment. The next choice would be to look at an SX or DI Type coupling. The 6 bolt SX Type will accommodate both parallel misalignment and the defined shaft separation. The size will be determined by the selection torque and the shaft diameters.

Step 2: Next, calculate the application torque and apply the service factor to calculate the selection torque.

The formula used to calculate torque is as follows:

$$\text{Application Torque (in-lb)} = \frac{(\text{HP} \times 63025)}{\text{RPM}}$$

$$\text{or Nm} = \frac{(\text{KW} \times 9550)}{\text{RPM}}$$

Plugging in the numbers from the application description:

Application Torque (in-lbs) =

$$\frac{(\text{HP} \times 63025)}{\text{RPM}} = \frac{(225 \times 63025)}{1150} = 12,331 \text{ in-lbs}$$

Application Torque x Service Factor = Selection Torque

$$12,331 \text{ in-lbs} \times 3.0 = 36,993 \text{ in-lbs}$$

Step 3: Use the SX coupling tables starting on page D-12 and note that the SX 202-6 is rated at 40,700 in-lbs, more than enough to

handle the selection torque calculated in step 2. The SX202-6, however, will not support the 92mm shaft size. The next larger size coupling, the SX228-6, will support the 92mm shaft size and the shaft separation dimension (BSE) is 6.88 inches, very close to the application's desired 7 inch separation. The SX228-6 is rated at 62,000 in-lbs which may seem to be excessive, however, the coupling size is necessary to handle the bore size.

Step 4: The SX228-6 coupling is rated for a maximum unbalanced speed of 3,400 RPM, more than enough to support the application speed of 1,150 RPM.

Step 5: To determine if the coupling will handle the parallel misalignment, use the trig function of $\tan 1^\circ = \text{offset allowed for 1 inch} = 0.0174$

Multiply the 0.0174 x the distance between disc packs or 'S' dimension from the table on page D-13, or 5.50 inches.

The allowable parallel offset is $0.0174 \times 5.50 = 0.096$ inches. The maximum offset for the application is 1/32 inches (0.031), therefore this coupling can accommodate the parallel misalignment.

Note: ■ It is always recommended to try to install the coupling at roughly 20% of the allowable misalignment. For this coupling the installer should try to achieve better than 0.020 parallel misalignment at the time of installation. This will allow for the additional misalignment that will occur as the result of equipment settle and general equipment wear.

Recommended Information Needed to Specify a Lovejoy Disc Coupling

The following information should be provided to Lovejoy when placing an order to ensure the proper selection of the disc coupling (see sample worksheet on page D-8):

- Application and type of duty
- Type of driver (engine, motor, turbine, etc.)
- Speed and horsepower
- Type of driven equipment
- Shaft sizes and separation
- Space limitations for major diameter and length
- Type of fit (Interference fit default, clearance fit and shaft locking device preparation available upon request)
- Special requirements (vertical mounting, drop out center, flange mount, electrically insulated, API-610 up to 3,800 RPM, shear pins, balancing, etc.)

Angular misalignment, axial misalignment, and rated torque are all related to the coupling's capacity to accommodate application torque over any period of time. As illustrated in the following charts, when the application torque increases to 50% of the coupling capacity, the ability of the coupling to accommodate angular misalignment is reduced. The same holds true for the ability to accommodate axial misalignment.

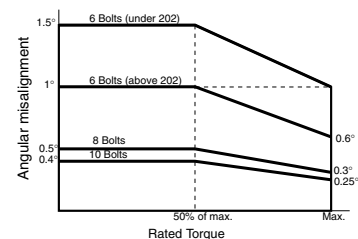
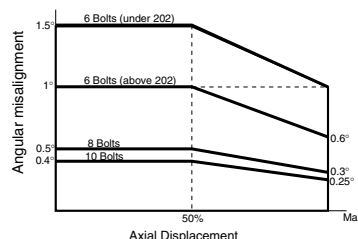

Selection Procedure

1. Select the coupling type.
2. Select the driven machine service factor SF_A from Table 1.
3. Select the driving machine service factor SF_D from Table 2.

Care should be taken when the driving machine is other than a standard electric motor or turbine. Some engines will impose extra fluctuations on the drive system and allowance should be made accordingly. Please refer to Table 2. A torsional coupling may be required for diesel drives.

The two service factors SF_A and SF_D must be added resulting in the combined service factor SF.

$$SF = SF_A + SF_D$$

Driven Machine Service Factor SFA Table

Table 1

Driven equipment	SF_A	MARINE APPLICATIONS	2.5	RUBBER INDUSTRY	
BLOWERS, FANS		MINING AND STONES		Extruder	1.75
Centrifugal	1.0	Crushers	2.5	Calender	2.0
Lobe / Vane / Turboblenders	1.25	Mills	2.5	Mixing mill / Refiner / Crusher	2.5
Forced draught fans	1.5	Mine ventilators	2.0	STEEL PLANTS	
Induc.draught with damper	1.5	Vibrators	1.5	Blast furnace blowers	1.5
Induc.draught without control	2.0	OIL INDUSTRY		Converters	2.5
Cooling towers	2.0	Pipeline pumps	1.5	Inclined blast furnace elev.	2.0
CHEMICAL INDUSTRY		Rotary drilling equipment	2.0	Crushers	2.0
Agitators (thin liquid)	1.0	PAPER INDUSTRY		TEXTILE MACHINES	
Agitators (viscous liquid)	1.5	Calenders	2.0	Printing and drying machines	1.5
Centrifuges (light)	1.25	Couches	2.0	Tanning vats	1.5
Centrifuges (heavy)	1.75	Drying cylinders	2.25	Calenders	1.5
Mixers	1.75	Pulpers	2.0	Looms	1.5
COMPRESSORS		Pulp grinders	2.0	WATER AND WASTE INDUSTRY	
Centrifugal	1.0	Suction rolls	2.0	Aerators, Screw pumps, Screens	1.5
Lobe/Rotary	1.25	Wet presses	2.0	WOOD WORKING MACHINERY	
Turbocompressors	1.75	Reels	2.0	Trimmers, Barkers, Saws, Planes	2.0
Reciprocating:		Agitators	2.0		
1 to 3 cylinders	3.0	PLASTIC INDUSTRY		Note: ■ 1 indicates: If people are transported, Lovejoy does not recommend and will not warranty the use of the coupling.	
4 or more cylinders	1.75	Calenders, Crushers, Mixers	1.75		
CONVEYOR, HOISTS¹, ELEVATORS¹		PUMPS		The factors in Table 1 are for general guidance and can be modified by customers' specialist knowledge of their own equipment.	
Conveyors:		Centrifugal, General Feed or Boiler Feed	1.0		
Screw / Apron / Belt / Chain	1.25	Centrifugal, Slurry	1.5	Driving Machine Service Factor SFD Table 2	
Bucket / Rotary / Lifts	1.5	Centrifugal, Dredge	2.0	Driving equipment	SF_D
Reciprocating	3.0	Rotary / Gear / Lobe or Vane	1.5	Multi-cylinder engine	
Hoists:		Reciprocating:		8 or more	0.5
Medium duty	2.5	1 cylinder	3.0	6	1.0
Heavy duty	3.0	2 cylinders, single acting	2.0	4 or 5	1.5
Elevators:		2 cylinders, double acting	1.75	Less than 4	<i>Refer to Lovejoy</i>
Centrifugal and gravity disch	1.25	3 cylinders or more	1.5	Variable speed motors	0.8
DREDGERS	2.0	ROLLING MILLS		Electric motors ¹ and turbines	0
FOOD INDUSTRY		Billet shears	2.5		
Packaging machines and fillers	1.25	Chain transfers	1.5	¹ Except variable speed motors	
Kneading machines	1.5	Cold rolling mills	2.0	Please consult our Application Engineering Department if axial excitations are foreseeable either on the driving or driven side.	
Cane crushers	1.5	Continuous casting plants	2.5		
Cane cutters	1.5	Cooling beds	1.5		
Cane mills	2.0	Cropping shears	2.0		
Sugar beet cutters	1.5	Cross transfers	1.5		
Sugar beet washing machines	1.5	Descaling machines	2.0		
GENERATORS		Heavy and medium duty mills	3.0		
Even load	1.0	Ingot and blooming mills	2.5		
Frequency converters	1.5	Ingot handling machinery	2.5		
Welding generators	2.0	Ingot pushers	2.5		
MACHINE TOOLS		Manipulators	2.0		
Main Drives	2.0	Plate shears	2.0		
Auxiliary and transverse drives	1.5	Roller adjustment drives	1.5		
METAL WORKING		Roller straighteners	1.5		
Presses/Hammers	2.0	Roller tables (heavy)	2.5		
Straighteners	2.0	Roller tables (light)	1.5		
Bending machines / Shears	1.5	Sheet mills	2.5		
Punching machines	2.0	Trimming shears	1.5		
		Tube and welding machines	2.0		
		Winding machines	1.5		
		Wire drawing benches	1.5		

Disc Coupling Selection Worksheet

Customer Name: _____

Contact Name: _____

Phone Number: _____

Email Address: _____

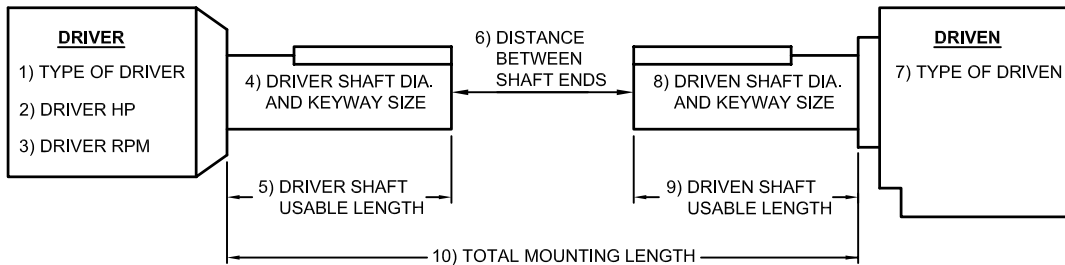

1. Type of Driver (Electric Motor, Combustion Engine, Gearbox, etc.) : _____

For combustion engines, define type
 Gasoline, Diesel, Natural Gas, etc. : _____ Number of cylinders _____

2. Driver Horse Power : _____ 3. Driver or Gearbox output RPM : _____

Retrieve the Application Service Factor from Page D-7 : _____ then
 calculate the Selection Torque using the following formula:

$$\text{Torque (in-lbs)} = \frac{\text{HP} \times 63025}{\text{RPM}} \times \text{Service Factor} = \text{Selection Torque} = \text{_____ in-lbs}$$

4. Driver Shaft Diameter : _____ Keyway size : KW Width _____ KW Height _____

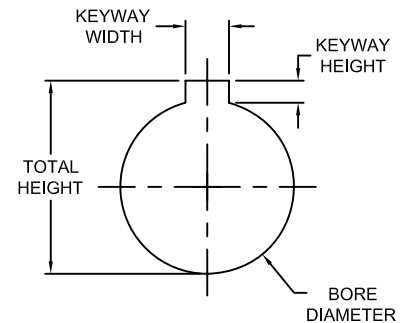

Specify Clearance Fit, Interference Fit, Metric (P7, H7, etc), Shaft Locking Device, and Set Screw or No Set Screw

5. Driver Usable Shaft Length : _____ (Measure from the end of the shaft to any obstruction)

6. Distance between shaft ends (BSE) : _____

7. Type of Driven Equipment : _____

8. Driven Shaft Diameter : _____ Keyway size : KW Width _____ KW Height _____

Specify Clearance Fit, Interference Fit, Metric (P7, H7, etc), Shaft Locking Device, and Set Screw or No Set Screw

9. Driven Usable Shaft Length : _____ (Measure from the end of the shaft to any obstruction)

10. Total Mounting Length : _____ (Advise of any obstructions, walls, beams, guards, pipes, etc.)

11. For Tapered Shafts specify the following:

Minimum or Maximum Taper diameter: _____

Taper Length: _____ T (Taper Inch per Foot) : _____

Gap or Hub Overhang amount: _____

Locknut Width: _____ Size of nut cross corners: _____

Thread Size: _____ Thread Length: _____

Washer Diameter (if used) : _____ Washer Width: _____

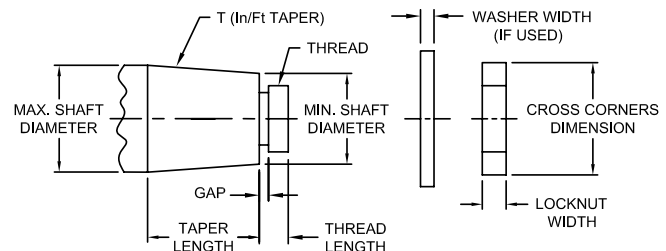

Performance Data by Size

Size	HP per 100 RPM	kW per 100 RPM	Nominal Torque in-lbs	Nominal Torque Nm	Peak Torque in-lbs	Peak Torque Nm	Torsional ¹ Stiffness x 10 ⁶ in-lbs/rad	Torsional ¹ Stiffness x 10 ⁶ Nm/rad	Axial ² Misalign ±DKa in	Axial ² Misalign ±DKa mm	Angular ³ Misalign Max Degrees
90-6	3.5	2.6	2,100	240	4,200	480	2.4	0.3	0.059	1.5	* 1.5°
110-6	8.0	6.0	5,100	575	10,200	1 150	3.4	0.4	0.083	2.1	
132-6	15.4	11.5	9,700	1 100	19,500	2 200	4.4	0.5	0.102	2.6	
158-6	28.2	21.0	17,700	2 000	35,400	4 000	5.8	0.7	0.122	3.1	
185-6	46.3	34.5	29,200	3 300	58,400	6 600	11.5	1.3	0.146	3.7	
202-6	64.6	48.2	40,700	4 600	81,400	9 200	13.3	1.5	0.150	3.8	* 1°
228-6	98.3	73.3	62,000	7 000	123,900	14 000	23.0	2.6	0.165	4.2	
255-6	143.2	106.8	90,300	10 200	180,600	20 400	41.0	4.7	0.185	4.7	
278-6	199.5	148.8	125,700	14 200	251,400	28 400	63.0	7.1	0.205	5.2	
302-6	281.1	209.6	177,000	20 000	354,000	40 000	84.0	9.5	0.224	5.7	
325-6	351.2	261.9	221,300	25 000	442,600	50 000	115.0	13.0	0.256	6.5	
345-6	436.0	325.0	274,400	31 000	549,000	62 000	150.0	17.0	0.272	6.9	
380-6	594.0	443.0	374,400	42 300	749,000	84 600	195.0	22.0	0.299	7.6	
410-6	802.0	598.0	505,400	57 100	1,011,000	114 200	248.0	28.0	0.323	8.2	
440-6	1033.0	770.0	650,500	73 500	1,301,000	147 000	310.0	35.0	0.346	8.8	

278-8	280.1	209.6	177,000	20 000	354,000	40 000	84.0	9.5	0.146	3.7	* .5°
302-8	421.5	314.3	265,500	30 000	531,000	60 000	132.0	14.9	0.157	4.0	
325-8	519.8	387.6	327,500	37 000	655,000	74 000	181.0	20.4	0.169	4.3	
345-8	646.0	482.0	407,100	46 000	814,200	92 000	221.0	25.0	0.181	4.6	
380-8	885.0	660.0	557,600	63 000	1,115,200	126 000	301.0	34.0	0.197	5.0	
410-8	1208.0	901.0	761,200	86 000	1,522,400	172 000	354.0	40.0	0.213	5.4	
440-8	1545.0	1152.0	973,600	110 000	1,947,200	220 000	434.0	49.0	0.228	5.8	
475-8	1939.0	1446.0	1,221,400	138 000	2,442,800	276 000	531.0	60.0	0.248	6.3	
505-8	2459.0	1833.0	1,548,900	175 000	3,097,800	350 000	646.0	73.0	0.264	6.7	
540-8	3091.0	2305.0	1,947,200	220 000	3,894,400	440 000	788.0	89.0	0.283	7.2	
570-8	3639.0	2713.0	2,292,300	259 000	4,584,600	518 000	912.0	103.0	0.299	7.6	

- Notes: ■ * indicates: See Page D-6 for additional information regarding misalignment.
 ■ 1 indicates: Torsional stiffness is provided for one disc pack. This should be combined with hubs, spacers, etc. as calculated from ANSI/AGMA 9004-A99.
 ■ 2 indicates: Axial misalignment is provided for couplings with two disc packs.
 ■ 3 indicates: Angular misalignment is provided per single disc pack.
 ■ For larger sizes, please contact Lovejoy Technical Support.

SU-6 Type Industrial Coupling

The SU Type coupling is a 6 bolt single flex plane coupling which consists of two hubs and one disc pack kit. It is only suitable for the specified axial and angular misalignment and does not accommodate parallel misalignment. It is often combined with solid shafts to make floating shaft couplings. See Page D-28 for a picture of an SXFS Type floating shaft coupling.

Features

- Unitized disc pack
- Infinite life when properly aligned
- Torsionally rigid without any back lash
- No need for lubrication or maintenance
- No wearing parts and high resistance to harsh environmental conditions
- Larger sizes are available upon request

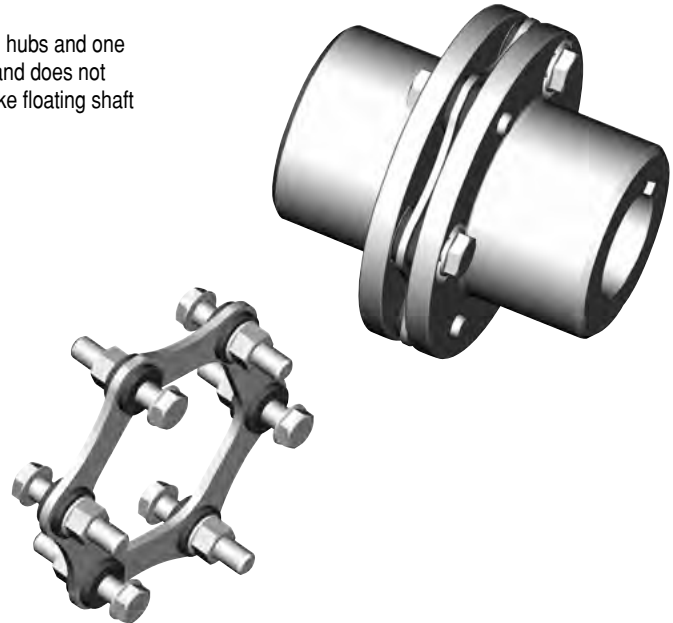

SU-6 Performance Data

Size	Nominal Torque		Peak Torque		Max Speed		ID1-ID2 Max Bore ³		Weight ⁴		Axial ⁵ Misalignment ± Δ Ka		Angular ⁶ Misalignment Max Degrees
	in-lbs	Nm	in-lbs	Nm	Unbal ¹ RPM	Bal ² RPM	in	mm	lbs	kg	in	mm	
90-6	2,100	240	4,200	480	9,100	22,700	1.50	38	3.1	1.4	0.030	0.75	1.5°
110-6	5,100	575	10,200	1 150	7,200	18,000	1.81	46	5.1	2.3	0.039	1.00	
132-6	9,700	1 100	19,500	2 200	5,840	14,600	2.38	60	8.4	3.8	0.051	1.30	
158-6	17,700	2 000	35,400	4 000	4,920	12,300	2.75	70	14.1	6.4	0.059	1.50	
185-6	29,200	3 300	58,400	6 600	4,200	10,500	3.13	80	21.8	9.9	0.071	1.80	
202-6	40,700	4 600	81,400	9 200	3,840	9,600	3.50	90	29.8	13.5	0.075	1.90	1°
228-6	62,000	7 000	123,900	14 000	3,400	8,500	3.94	100	41.9	19.0	0.083	2.10	
255-6	90,300	10 200	180,600	20 400	3,080	7,700	4.31	110	63.9	29.0	0.091	2.30	
278-6	125,700	14 200	251,400	28 400	2,800	7,000	4.88	124	81.6	37.0	0.102	2.60	
302-6	177,000	20 000	354,000	40 000	2,560	6,400	5.31	135	108.0	49.0	0.110	2.80	
325-6	221,300	25 000	442,600	50 000	2,400	6,000	5.75	145	133.4	60.5	0.126	3.20	
345-6	274,400	31 000	549,000	62 000	2,200	5,500	6.06	155	160.9	73.0	0.134	3.40	
380-6	374,400	42 300	749,000	84 600	2,040	5,100	6.69	170	211.6	96.0	0.150	3.80	
410-6	505,400	57 100	1,011,000	114 200	1,880	4,700	7.13	180	273.4	124.0	0.161	4.10	
440-6	650,500	73 500	1,301,000	147 000	1,740	4,350	7.69	195	332.9	151.0	0.173	4.40	

- Notes:
- * indicates: Operating speed must be equal or less than permissible speed.
 - 2 indicates: Couplings as manufactured can accommodate maximum speeds as listed. Higher speeds listed as 'Bal' require special balancing.
 - 3 indicates: The maximum bores shown are for cylindrical or taper shafts with keys. For splines and other bore types, contact Lovejoy Technical Support.
 - 4 indicates: Weight is given for a complete coupling with maximum bores.
 - 5 indicates: Axial misalignment is given for one disc pack.
 - 6 indicates: Angular misalignment is given for one disc pack. There is no parallel misalignment for the SU Type.

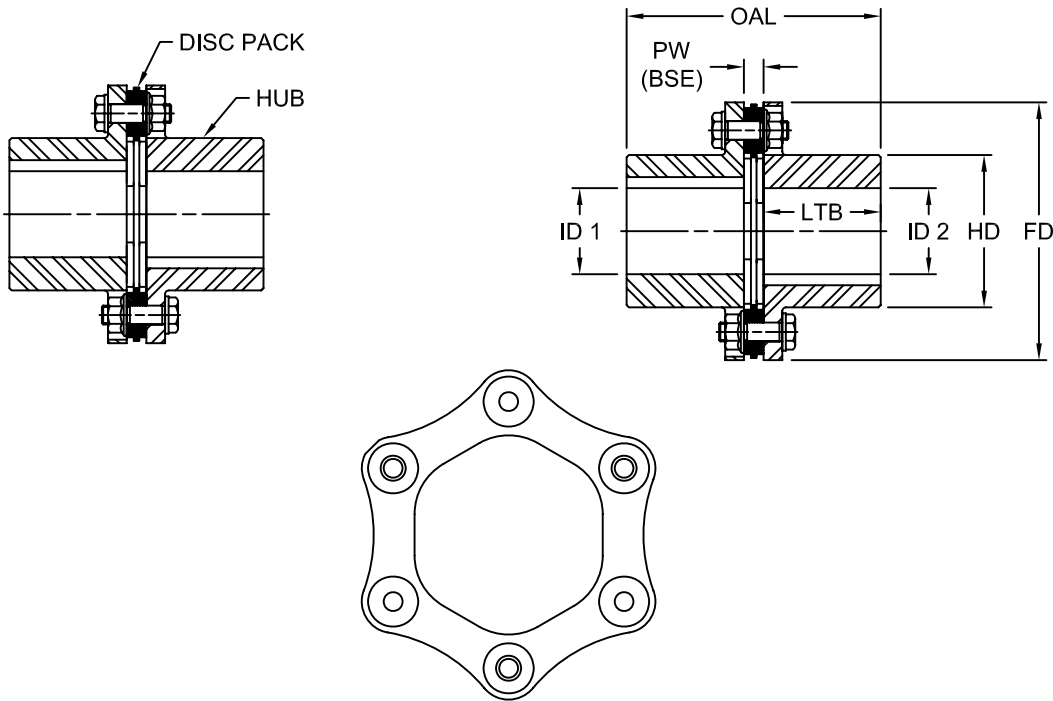

SU-6 Dimensional Data

Size	OAL		PW - BSE		LTB		ID1-ID2 Max Bore ³		FD		HD	
	in	mm	in	mm	in	mm	in	mm	in	mm	in	mm
90-6	3.44	88	0.295	7.5	1.57	40	1.50	38	3.54	90	2.28	58
110-6	4.27	108	0.331	8.4	1.97	50	1.81	46	4.33	110	2.56	65
132-6	5.05	128	0.331	8.4	2.36	60	2.38	60	5.20	132	3.31	84
158-6	5.96	151	0.441	11.2	2.76	70	2.75	70	6.22	158	3.86	98
185-6	6.85	174	0.551	14.0	3.15	80	3.13	80	7.28	185	4.41	112
202-6	7.69	196	0.610	15.5	3.54	90	3.50	90	7.95	202	4.92	125
228-6	8.57	218	0.689	17.5	3.94	100	3.94	100	8.98	228	5.51	140
255-6	9.87	251	0.807	20.5	4.53	115	4.31	110	10.04	255	6.10	155
278-6	10.67	271	0.835	21.2	4.92	125	4.88	124	10.95	278	6.85	174
302-6	11.60	294	0.961	24.4	5.32	135	5.31	135	11.89	302	7.48	190
325-6	12.44	316	1.024	26.0	5.71	145	5.75	145	12.80	325	8.07	205
345-6	13.31	338	1.110	28.2	6.10	155	6.06	155	13.58	345	8.55	217
380-6	14.66	372	1.260	32.0	6.70	170	6.69	170	14.96	380	9.37	238
410-6	15.87	403	1.307	33.2	7.28	185	7.13	180	16.14	410	10.04	255
440-6	16.79	426	1.433	36.4	7.68	195	7.69	195	17.32	440	10.75	273

- Notes: ■ 3 indicates: The maximum bores shown are for cylindrical or taper shafts with keys. For splines and other bore types, contact Lovejoy Technical Support.
 ■ Metric dimensions are rounded to the nearest 'mm' except where otherwise shown.
 ■ Larger sizes available upon request.

SX-6 Type Industrial Coupling

The SX-6 Type is a standard coupling with two hubs, a spacer, and two disc pack kits. The coupling has two flex planes (one at each disc pack) so it can accommodate parallel misalignment by the angular misalignment in each disc pack. This configuration will also accommodate axial misalignment within the specified limits.

Features

- Unitized disc pack
- Infinite life when properly sized and aligned
- Accommodates angular, axial, and parallel misalignment
- Torsionally rigid without any back lash
- No need for lubrication or maintenance
- No wearing parts and high resistance to harsh environmental conditions
- Overload Bushings are available, see page D-4

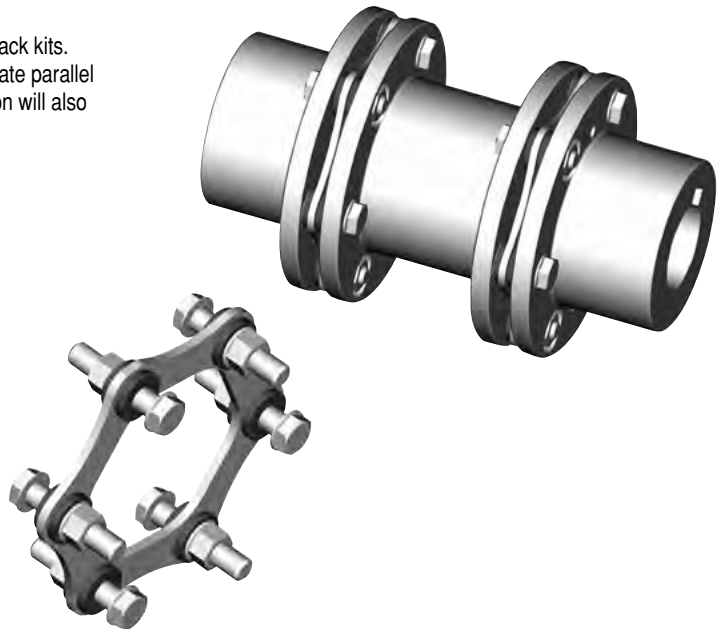

SX-6 Performance Data

Size	Nominal Torque		Peak Torque		Max Speed		ID1-ID2 Max Bore ³		Weight ⁴		Axial ⁵ Misalignment $\pm \Delta K_a$		Angular ⁶ Misalignment Max Degrees
	in-lbs	Nm	in-lbs	Nm	Unbal ¹ RPM	Bal ² RPM	in	mm	lbs	kg	in	mm	
90-6	2,100	240	4,200	480	9,100	22,700	1.50	38	4.6	2.1	0.059	1.5	1.5°
110-6	5,100	575	10,200	1 150	7,200	18,000	1.81	46	6.4	2.9	0.083	2.1	
132-6	9,700	1 100	19,500	2 200	5,840	14,600	2.38	60	12.1	5.5	0.102	2.6	
158-6	17,700	2 000	35,400	4 000	4,920	12,300	2.76	70	19.0	8.6	0.122	3.1	
185-6	29,200	3 300	58,400	6 600	4,200	10,500	3.13	80	33.1	15.0	0.146	3.7	
202-6	40,700	4 600	81,400	9 200	3,840	9,600	3.50	90	46.3	21.0	0.150	3.8	1°
228-6	62,000	7 000	123,900	14 000	3,400	8,500	3.94	100	66.1	30.0	0.165	4.2	
255-6	90,300	10 200	180,600	20 400	3,080	7,700	4.31	110	88.2	40.0	0.185	4.7	
278-6	125,700	14 200	251,400	28 400	2,800	7,000	4.88	124	125.7	57.0	0.205	5.2	
302-6	177,000	20 000	354,000	40 000	2,560	6,400	5.31	135	163.1	74.0	0.224	5.7	
325-6	221,300	25 000	442,600	50 000	2,400	6,000	5.75	145	196.2	89.0	0.256	6.5	
345-6	274,400	31 000	549,000	62 000	2,200	5,500	6.06	155	240.3	109.0	0.272	6.9	
380-6	374,400	42 300	749,000	84 600	2,040	5,100	6.69	170	321.9	146.0	0.299	7.6	
410-6	505,400	57 100	1,011,000	114 200	1,880	4,700	7.13	180	418.8	190.0	0.323	8.2	
440-6	650,500	73 500	1,301,000	147 000	1,740	4,350	7.69	195	493.8	224.0	0.346	8.8	

- Notes:
- 1 indicates: Operating speed must be equal or less than permissible speed. Permissible speeds could be limited by the weight and the critical speeds of the spacer.
 - 2 indicates: Couplings as manufactured can accommodate maximum speeds as listed. Higher speeds up to the value shown as "Bal" require special balancing.
 - 3 indicates: The maximum bores shown are for cylindrical or taper shafts with keys. For splines and other type bores contact Lovejoy Technical Support.
 - 4 indicates: Weight is given for a complete coupling with minimum BSE and maximum bores.
 - 5 indicates: Axial misalignment is given for two disc packs.
 - 6 indicates: Angular misalignment is given for single disc pack.
 - For higher torque capacities, see SX-8 Type couplings on page D-14 and D-15.

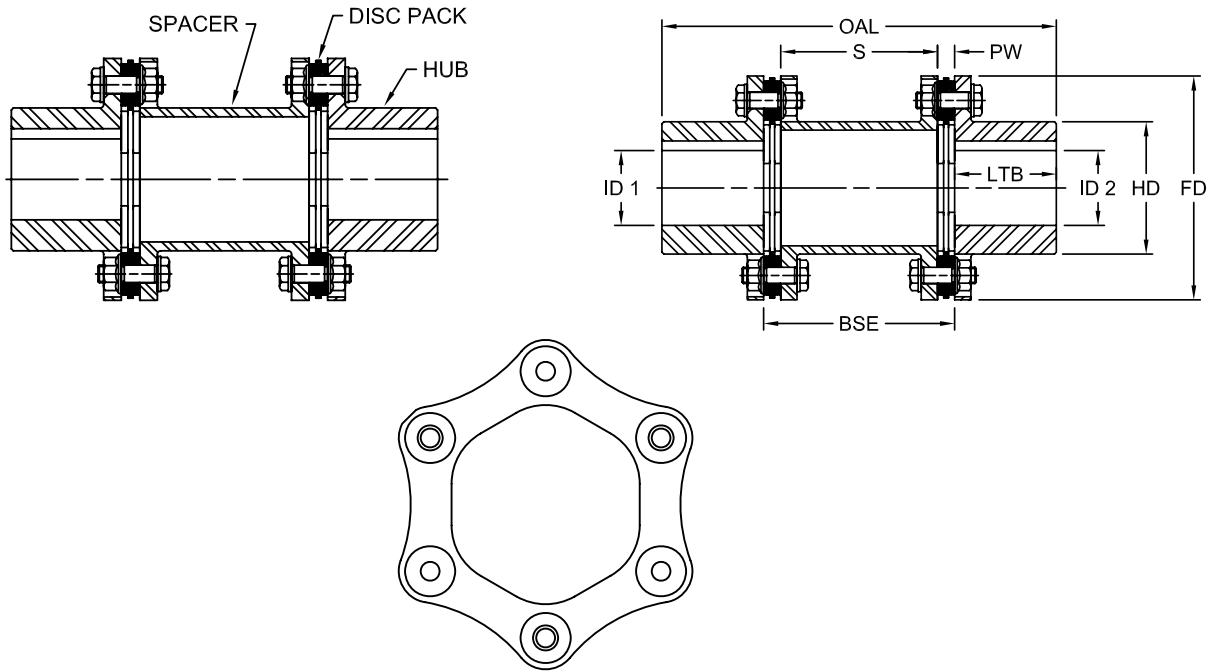

SX-6 Dimensional Data

Size	OAL		S		PW		LTB		ID1-ID2 Max Bore ³		BSE ⁷ Standard		FD		HD	
	in	mm	in	mm	in	mm	in	mm	in	mm	in	mm	in	mm	in	mm
90-6	5.50	140	1.77	45	0.295	7.5	1.57	40	1.50	38	2.36	60	3.54	90	2.28	58
110-6	7.44	189	2.84	72	0.331	8.4	1.97	50	1.81	46	3.50	89	4.33	110	2.56	65
132-6	8.97	228	3.59	91	0.331	8.4	2.36	60	2.38	60	4.25	108	5.20	132	3.31	84
158-6	10.40	264	4.00	102	0.441	11.2	2.76	70	2.76	70	4.88	124	6.22	158	3.86	98
185-6	11.80	300	4.40	112	0.551	14.0	3.15	80	3.13	80	5.50	140	7.28	185	4.41	112
202-6	13.33	339	5.03	128	0.610	15.5	3.54	90	3.50	90	6.25	159	7.95	202	4.92	125
228-6	14.76	375	5.50	140	0.689	17.5	3.94	100	3.94	100	6.88	175	8.98	228	5.51	140
255-6	16.81	427	6.14	156	0.807	20.5	4.53	115	4.31	110	7.75	197	10.04	255	6.10	155
278-6	18.47	469	6.96	177	0.835	21.2	4.92	125	4.88	124	8.63	219	10.95	278	6.85	174
302-6	19.89	505	7.33	186	0.961	24.4	5.32	135	5.31	135	9.25	235	11.89	302	7.48	190
325-6	21.42	544	7.95	202	1.024	26.0	5.71	145	5.75	145	10.00	254	12.80	325	8.07	205
345-6	22.83	580	8.41	214	1.110	28.2	6.10	155	6.06	155	10.63	270	13.58	345	8.55	217
380-6	25.08	637	9.16	233	1.260	32.0	6.70	170	6.69	170	11.68	297	14.96	380	9.37	238
410-6	27.18	690	10.01	254	1.307	33.2	7.28	185	7.13	180	12.62	321	16.14	410	10.04	255
440-6	28.55	725	10.32	262	1.433	36.4	7.68	195	7.69	195	13.19	335	17.32	440	10.75	273

Notes: ■ 3 indicates: The maximum bores shown are for cylindrical or taper shafts with keys. For splines and other type bores contact Lovejoy Technical Support.
 ■ 7 indicates: BSE is the distance between shaft ends and is a variable parameter.
 ■ Metric dimensions are rounded to the nearest 'mm' except where otherwise shown.

SX-8 Type Industrial Coupling

The SX-8 Type is a standard coupling with two hubs, a spacer, and two disc pack kits. The coupling has two flex planes (one at each disc pack) so it can accommodate parallel misalignment by the angular misalignment in each disc pack. This configuration will also accommodate axial misalignment within the specified limits.

Features

- Unitized disc pack
- Infinite life if properly aligned
- Accommodates angular, axial, and parallel misalignment
- Torsionally rigid without any back lash
- No need for lubrication or maintenance
- No wearing parts and high resistance to harsh environmental conditions

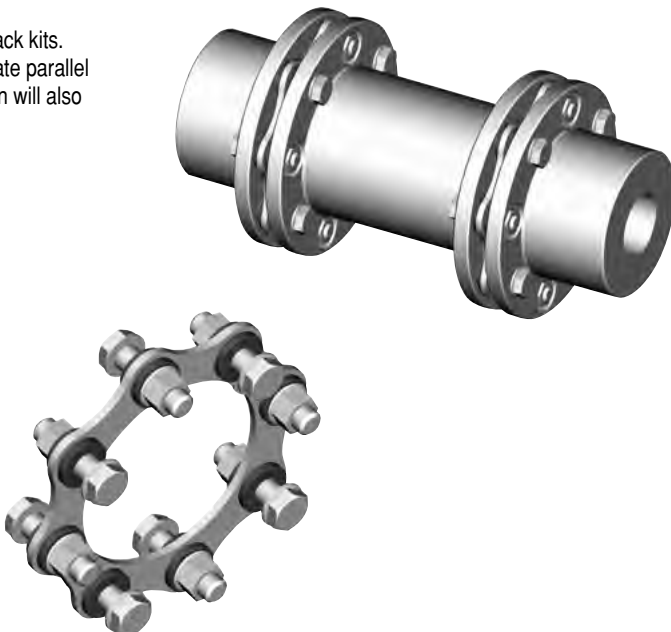

SX-8 Performance Data

Size	Nominal Torque		Peak Torque		Max Speed		ID1-ID2 Max Bore ³		Weight ⁴		Axial ⁵ Misalignment ±ΔKa		Angular ⁶ Misalignment Max Degrees
	in-lbs	Nm	in-lbs	Nm	Unbal ¹ RPM	Bal ² RPM	in	mm	lbs	kg	in	mm	
278-8	177,000	20 000	354,000	40 000	2,800	7,000	4.88	124	130	59	0.146	3.7	.5°
302-8	265,500	30 000	531,000	60 000	2,560	6,400	5.38	135	169	77	0.157	4.0	
325-8	327,500	37 000	655,000	74 000	2,400	6,000	5.75	145	202	92	0.169	4.3	
345-8	407,000	46 000	814,200	92 000	2,200	5,500	6.13	155	246	112	0.181	4.6	
380-8	558,000	63 000	1,115,000	126 000	2,040	5,100	6.63	170	330	150	0.197	5.0	
410-8	761,000	86 000	1,522,000	172 000	1,880	4,700	7.13	180	429	195	0.213	5.4	
440-8	974,000	110 000	1,947,000	220 000	1,740	4,350	7.69	195	506	230	0.228	5.8	
475-8	1,221,000	138 000	2,443,000	276 000	1,680	4,200	8.25	210	649	295	0.248	6.3	
505-8	1,549,000	175 000	3,098,000	350 000	1,520	3,800	8.88	220	823	374	0.264	6.7	
540-8	1,947,000	220 000	3,894,000	440 000	1,440	3,600	9.25	235	999	454	0.283	7.2	

- Notes:
- 1 indicates: Operating speed must be equal or less than permissible speed. Permissible speeds could be limited by the weight and the critical speeds of the spacer.
 - 2 indicates: Couplings as manufactured can accommodate maximum speeds as listed. Higher speeds up to the value shown as 'Bal' require special balancing.
 - 3 indicates: The maximum bores shown are for cylindrical or taper shafts with keys. For splines and other type bores contact Lovejoy Technical Support.
 - 4 indicates: Weight is given for a complete coupling with minimum BSE and maximum bores.
 - 5 indicates: Axial misalignment is given for two disc packs.
 - 6 indicates: Angular misalignment is given for single disc pack.
 - For larger sizes and higher torque capacities, contact Lovejoy Technical Support.

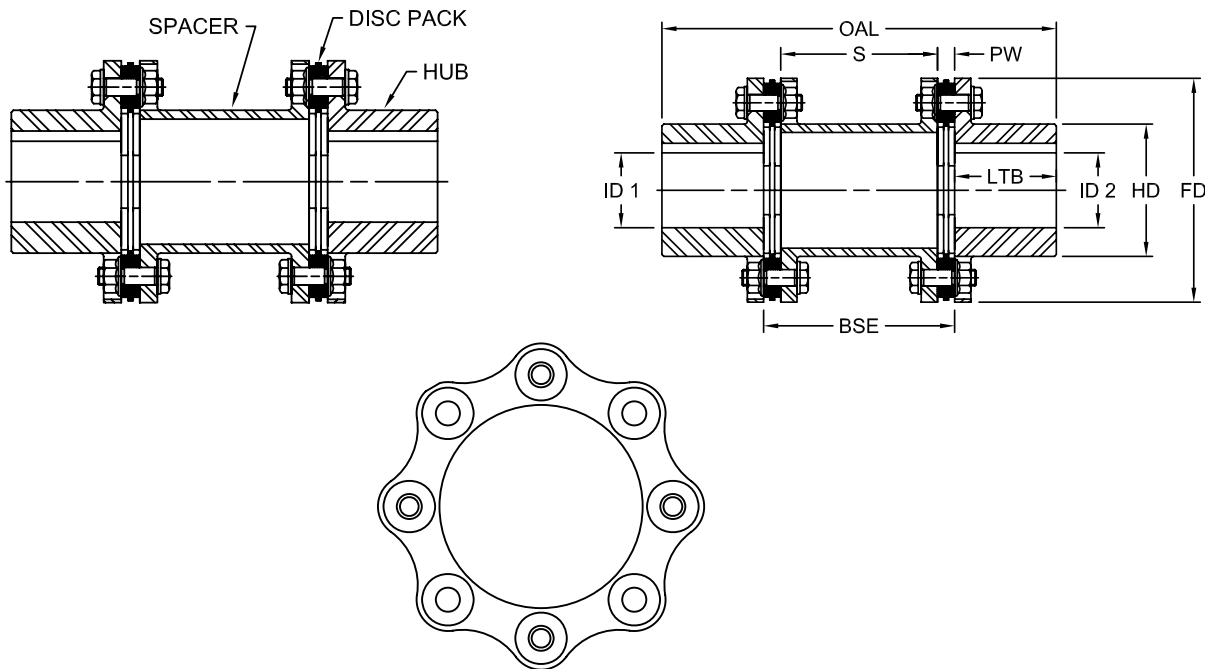

SX-8 Dimensional Data

Size	OAL		S		PW		LTB		ID1-ID2 Max Bore ³		BSE ⁷ Standard		FD		HD	
	in	mm	in	mm	in	mm	in	mm	in	mm	in	mm	in	mm	in	mm
278-8	18.47	469	6.96	177	0.835	21.2	4.92	125	4.88	124	8.63	219	10.95	278	6.85	174
302-8	19.89	505	7.33	186	0.961	24.4	5.32	135	5.38	135	9.25	235	11.89	302	7.48	190
325-8	21.42	544	7.95	202	1.024	26.0	5.71	145	5.75	145	10.00	254	12.80	325	8.07	205
345-8	22.83	580	8.41	214	1.110	28.2	6.10	155	6.13	155	10.63	270	13.58	345	8.55	217
380-8	25.08	637	9.16	233	1.260	32.0	6.70	170	6.63	170	11.68	297	14.96	380	9.37	238
410-8	27.18	690	10.01	254	1.307	33.2	7.28	185	7.13	180	12.62	321	16.14	410	10.04	255
440-8	28.55	725	10.32	262	1.433	36.4	7.68	195	7.69	195	13.19	335	17.32	440	10.75	273
475-8	30.67	779	11.12	283	1.504	38.2	8.27	210	8.25	210	14.13	359	18.70	475	11.62	295
505-8	33.62	854	12.19	310	1.654	42.0	9.06	230	8.88	220	15.50	394	19.88	505	12.20	310
540-8	35.28	896	12.76	324	1.811	46.0	9.45	240	9.25	235	16.38	416	21.26	540	12.99	330

Notes: ■ 3 indicates: The maximum bores shown are for cylindrical or taper shafts with keys. For splines and other type bores contact Lovejoy Technical Support.

■ 7 indicates: BSE is the distance between shaft ends and is a variable parameter.

■ Metric dimensions are rounded to the nearest 'mm' except where otherwise shown.

SXC-6 Type Closed Coupled Industrial Coupling

The SXC-6 Type is the standard 6 bolt coupling with two hubs, two disc packs and a spacer. The hubs can both be turned inward to accommodate close coupled applications or one hub can be turned outward to accommodate additional BSE's (shaft separation). The coupling has two flex planes (one at each disc pack) so it can accommodate parallel misalignment by the angular misalignment in each disc pack. This configuration will also accommodate axial misalignment within the specified limits.

Features

- Unitized disc packs
- Infinite life if properly aligned
- Torsionally rigid without any back lash
- No need for lubrication or maintenance
- No wearing parts and high resistance to harsh environmental conditions
- Can be combined with SU/SX hub for increased bore capacity (See page D-15)

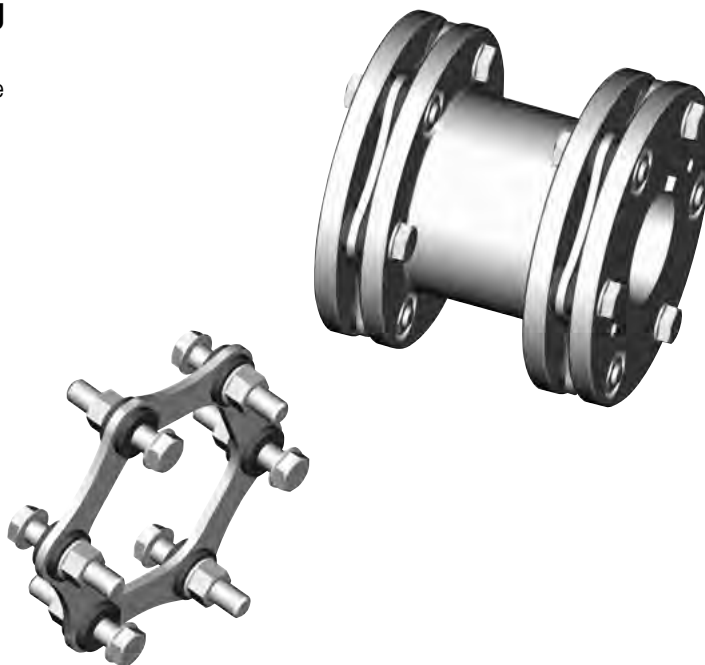

SXC-6 Performance Data

Size	Nominal Torque		Peak Torque		Max Speed		ID1-ID2 Max Bore ³		Weight ⁴		Axial ⁵ Misalignment ± Δ Ka		Angular ⁶ Misalignment Max Degrees
	in-lbs	Nm	in-lbs	Nm	Unbal ¹ RPM	Bal ² RPM	in	mm	lbs	kg	in	mm	
110-6	5,100	600	10,200	1 200	7,200	18,000	1.56	39	4	1.8	0.083	2.1	1.5°
132-6	9,700	1 100	19,500	2 200	5,840	14,600	2.06	50	8	3.8	0.102	2.6	
158-6	17,700	2 000	35,400	4 000	4,920	12,300	2.38	60	13	5.8	0.122	3.1	
185-6	29,200	3 300	58,400	6 600	4,200	10,500	2.68	68	22	10.0	0.146	3.7	
202-6	40,700	4 600	81,400	9 200	3,840	9,600	3.06	75	33	15.0	0.150	3.8	1°
228-6	62,000	7 000	123,900	14 000	3,400	8,500	3.44	85	46	21.0	0.165	4.2	
255-6	90,300	10 200	180,600	20 400	3,080	7,700	3.88	95	60	27.0	0.185	4.7	
278-6	125,700	14 200	251,400	28 400	2,800	7,000	4.25	105	79	36.0	0.205	5.2	
302-6	177,000	20 000	354,000	40 000	2,560	6,400	4.63	115	101	46.0	0.224	5.7	
325-6	221,300	25 000	442,600	50 000	2,400	6,000	4.88	125	121	55.0	0.256	6.5	
345-6	274,400	31 000	548,800	62 000	2,200	5,500	5.25	130	154	70.0	0.272	6.9	
380-6	374,400	42 300	748,800	84 600	2,040	5,100	5.75	145	203	92.0	0.299	7.6	
410-6	505,400	57 100	1,011,000	114 200	1,880	4,700	6.25	160	256	116.0	0.323	8.2	
440-6	650,500	73 500	1,301,000	147 000	1,740	4,350	6.50	165	300	136.0	0.346	8.8	

- Notes:
- 1 indicates: Operating speed must be equal or less than permissible speed. Permissible speeds could be limited by the weight and the critical speeds of the spacer.
 - 2 indicates: Couplings as manufactured can accommodate maximum speeds as listed. Higher speeds up to the value shown as "Bal" require special balancing.
 - 3 indicates: The maximum bores shown are for cylindrical or taper shafts with keys. For other type of connections contact Lovejoy Technical Support.
 - 4 indicates: Weight is given for a complete coupling with minimum BSE and maximum bores.
 - 5 indicates: Axial misalignment is given for two disc packs.
 - 6 indicates: Angular misalignment is given for one disc pack.
 - SU/SX hubs can be used (turned outward) to accommodate maximum bore sizes for the specified hub.

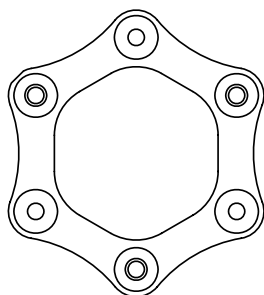
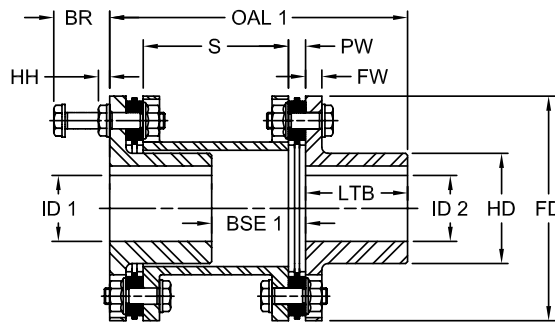
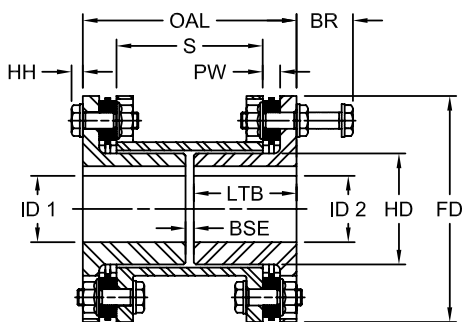

BSE1: To calculate the BSE 1 (Between Shaft Ends) with one hub turned out
 $BSE\ 1 = BSE + LTB - FW$

OAL1: To calculate the OAL 1 (Overall Length) with one hub turned out
 $OAL\ 1 = OAL + LTB - FW$

SXC-6 Dimensional Data

Size	OAL		BR ⁸		S		HH		PW		LTB		BSE ⁷ Standard		FD		HD		FW	
	in	mm	in	mm	in	mm	in	mm	in	mm	in	mm	in	mm	in	mm	in	mm	in	mm
110-6	4.12	105	1.77	45	2.84	72	0.24	6	0.33	8.4	1.97	50	0.18	5	4.33	110	2.13	54	0.31	8
132-6	4.87	124	1.77	45	3.59	91	0.24	6	0.33	8.4	2.36	60	0.15	4	5.20	132	2.79	71	0.31	8
158-6	5.66	144	2.17	55	4.00	102	0.28	7	0.44	11.2	2.76	70	0.14	4	6.22	158	3.31	84	0.39	10
185-6	6.44	164	2.56	65	4.40	112	0.31	8	0.55	14.0	3.15	80	0.14	4	7.28	185	3.74	95	0.47	12
202-6	7.35	187	2.95	75	5.03	128	0.35	9	0.61	15.5	3.54	90	0.27	7	7.95	202	4.25	108	0.55	14
228-6	8.14	207	3.35	85	5.50	140	0.39	10	0.69	17.5	3.94	100	0.26	7	8.98	228	4.84	123	0.63	16
255-6	9.33	237	3.94	100	6.14	156	0.51	13	0.81	20.5	4.53	115	0.27	7	10.04	255	5.43	138	0.79	20
278-6	10.20	259	4.13	105	6.96	177	0.51	13	0.84	21.2	4.92	125	0.35	9	10.95	278	5.99	152	0.79	20
302-6	10.99	279	4.53	115	7.33	186	0.55	14	0.96	24.4	5.32	135	0.35	9	11.89	302	6.50	165	0.87	22
325-6	11.74	298	4.53	115	7.95	202	0.55	14	1.02	26.0	5.71	145	0.32	8	12.80	325	6.85	174	0.87	22
345-6	12.51	318	4.92	125	8.41	214	0.59	15	1.11	28.2	6.10	155	0.31	8	13.58	345	7.32	186	0.94	24
380-6	13.80	350	5.51	140	9.16	233	0.67	17	1.26	32.0	6.70	170	0.40	10	14.96	380	8.03	204	1.06	27
410-6	14.98	380	5.91	150	10.01	254	0.75	19	1.31	33.2	7.28	185	0.42	11	16.14	410	8.78	223	1.18	30
440-6	15.79	401	6.50	165	10.32	262	0.83	21	1.43	36.4	7.68	195	0.43	11	17.32	440	9.17	233	1.30	33

- Notes:
- 7 indicates: BSE is the distance between shaft ends and is a variable parameter.
 - 8 indicates: Customer is responsible for ensuring there is enough room between the coupling and equipment to install the bolts and properly torque them with a torque wrench. Additional shaft length may be required. See Disc Coupling Worksheet, page D-8 item 5.
 - Metric dimensions are rounded to the nearest 'mm' except where otherwise shown.
 - ID1 – ID2 Dimensional Data on page D-16.

SXCS-6 Type Closed Coupled Industrial Coupling

The SXCS Type is the standard 6 bolt coupling with two hubs, two mounting rings, two disc packs and a split spacer designed for ease of installation and maintenance. Custom spacer lengths can be specified for special applications. The coupling has two flex planes (one at each disc pack) allowing it to accommodate parallel misalignment by the angular misalignment in each disc pack. This configuration will also accommodate axial misalignment within the specified limits.

Features

- Unitized disc pack
- Infinite life when properly sized and aligned
- Torsionally rigid without any back lash
- No need for lubrication or maintenance
- No wearing parts and high resistance to harsh environmental conditions
- Disc packs can be replaced without moving equipment
- For larger sizes, refer to SXCST couplings, see Page D-20



SXCS-6 Performance Data

Size	Nominal Torque		Peak Torque		Max Speed		ID1 - ID2 Max Bore ³		Weight ⁴		Axial ⁵ Misalignment ± Δ Ka		Angular ⁶ Misalignment Max Degrees
	in-lbs	Nm	in-lbs	Nm	Unbal ¹ RPM	Bal ² RPM	in	mm	lbs	kg	in	mm	
110-6	5,100	575	10,200	1 150	7,200	18,000	1.56	40	16.5	7.5	0.083	2.1	1.5°
132-6	9,700	1 100	19,500	2 200	5,840	14,600	2.06	52	24.3	11.0	0.102	2.6	
158-6	17,700	2 000	35,400	4 000	4,920	12,300	2.38	60	41.9	19.0	0.122	3.1	
185-6	29,200	3 300	58,400	6 600	4,200	10,500	2.68	68	64.0	29.0	0.146	3.7	
202-6	40,700	4 600	81,400	9 200	3,840	9,600	3.06	78	84.0	38.0	0.150	3.8	1°
228-6	62,000	7 000	123,900	14 000	3,400	8,500	3.44	87	126.0	57.0	0.165	4.2	
255-6	90,300	10 200	180,600	20 400	3,080	7,700	3.88	99	185.0	84.0	0.185	4.7	
278-6	125,700	14 200	251,400	28 400	2,800	7,000	4.25	108	230.0	104.0	0.205	5.2	
302-6	177,000	20 000	354,000	40 000	2,560	6,400	4.63	118	306.0	139.0	0.224	5.7	

- Notes:
- 1 indicates: Operating speed must be equal or less than permissible speed which is limited by the weight and critical speed of the spacer.
 - 2 indicates: Couplings as manufactured can accommodate maximum speeds as listed. Higher speeds up to the value shown as 'Bal' require special balancing.
 - 3 indicates: The maximum bores shown are for cylindrical or taper shafts with keys. For other type of connections contact Lovejoy Technical Support.
 - 4 indicates: Weight is given for a complete coupling with minimum BSE and maximum bores.
 - 5 indicates: Axial misalignment is given for two disc packs.
 - 6 indicates: Angular misalignment is given for one disc pack.

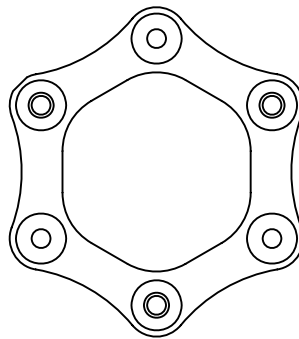
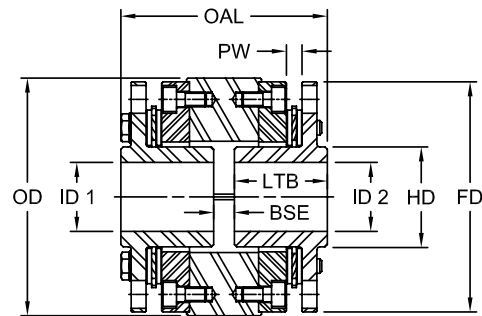
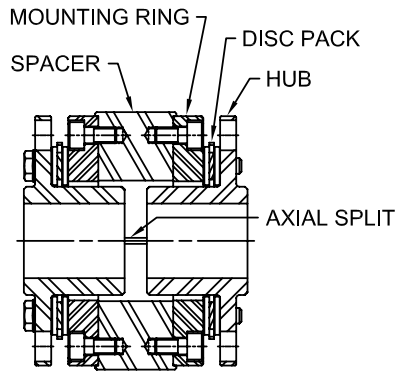

SXCS-6 Dimensional Data

Size	OAL ⁸		PW		LTB		ID1 - ID2 Max Bore ³		BSE ⁷ Standard		FD		HD		OD	
	in	mm	in	mm	in	mm	in	mm	in	mm	in	mm	in	mm	in	mm
110-6	4.38	111.3	0.331	8.4	1.97	50	1.56	40	0.44	11.2	4.88	124.0	2.13	54	5.04	128.0
132-6	5.08	129.0	0.331	8.4	2.36	60	2.06	52	0.36	9.1	5.71	145.0	2.79	71	5.87	149.1
158-6	5.99	152.1	0.441	11.2	2.76	70	2.38	60	0.47	11.9	6.73	170.9	3.31	84	6.89	175.0
185-6	6.88	174.8	0.551	14.0	3.15	80	2.68	68	0.58	14.7	7.68	195.1	3.74	95	7.83	198.9
202-6	7.72	196.1	0.610	15.5	3.54	90	3.06	78	0.64	16.3	8.43	214.1	4.25	108	8.58	217.9
228-6	8.60	218.4	0.689	17.5	3.94	100	3.44	87	0.72	18.3	9.57	243.1	4.84	123	9.72	246.9
255-6	10.27	260.9	0.807	20.5	4.53	115	3.88	99	1.21	30.7	10.79	274.1	5.43	138	10.94	277.9
278-6	10.71	272.0	0.835	21.2	4.92	125	4.25	108	0.87	22.1	11.58	294.1	5.99	152	11.73	297.9
302-6	11.72	297.7	0.961	24.4	5.32	135	4.63	118	1.08	27.4	12.88	327.2	6.50	165	13.03	331.0

- Notes:
- 3 indicates: The maximum bores shown are for cylindrical or taper shafts with keys. For splines and other types of bores, contact Lovejoy Technical Support.
 - 7 indicates: BSE is the distance between shaft ends and is a variable parameter.
 - 8 indicates: OAL is measured from the end of the hubs and does not include the bolt heads.
 - Customer is responsible for ensuring there is enough room between the coupling and equipment to install the bolts and properly torque them with a torque wrench. Additional shaft length may be required. See Disc Coupling Worksheet, page D-8 item 5.

SXCST-6 Type Closed Coupled Industrial Coupling

The SXCST Type is a standard 6 bolt coupling consisting of two hubs, two mounting rings, two disc packs and a split spacer. Custom spacer lengths can be specified for special applications. The coupling has two flex planes (one at each disc pack) so it can accommodate parallel misalignment by the angular misalignment in each disc pack. This configuration will also accommodate axial misalignment within the specified limits.

Features

- Unitized disc pack
- Infinite life when properly sized and aligned
- Accommodates angular, axial, and parallel misalignment
- Torsionally rigid without any back lash
- No need for lubrication or maintenance
- No wearing parts and high resistance to harsh environmental conditions
- Close coupled
- Split spacer design allows for ease of maintenance and disc pack removal or replacement without moving equipment



SXCST-6 Performance Data

Size	Nominal Torque		Peak Torque		Max Speed		ID1 - ID2 Max Bore ³		Axial ⁴ Misalignment ± ΔKa		Angular ⁵ Misalignment Max Degrees
	in-lbs	Nm	in-lbs	Nm	Unbal ¹ RPM	Bal ² RPM	in	mm	in	mm	
90-6	2,100	240	4,200	480	9,100	22,700	1.20	31	0.059	1.5	1.5°
110-6	5,100	575	10,200	1 150	7,200	18,000	1.56	39	0.083	2.1	
132-6	9,700	1 100	19,500	2 200	5,840	14,600	2.06	50	0.102	2.6	
158-6	17,700	2 000	35,400	4 000	4,920	12,300	2.38	60	0.122	3.1	
185-6	29,200	3 300	58,400	6 600	4,200	10,500	2.68	68	0.146	3.7	
202-6	40,700	4 600	81,400	9 200	3,840	9,600	3.06	75	0.150	3.8	1°
228-6	62,000	7 000	123,900	14 000	3,400	8,500	3.44	85	0.165	4.2	
255-6	90,300	10 200	180,600	20 400	3,080	7,700	3.88	95	0.185	4.7	
278-6	125,700	14 200	251,400	28 400	2,800	7,000	4.25	105	0.205	5.2	
302-6	177,000	20 000	354,000	40 000	2,560	6,400	4.63	115	0.224	5.7	
325-6	221,300	25 000	442,600	50 000	2,400	6,000	4.88	125	0.256	6.5	
345-6	274,400	31 000	549,000	62 000	2,200	5,500	5.25	130	0.272	6.9	
380-6	374,400	42 300	749,000	84 600	2,040	5,100	5.75	145	0.299	7.6	
410-6	505,400	57 100	1,011,000	114 200	1,880	4,700	6.25	160	0.323	8.2	
440-6	650,500	73 500	1,301,000	147 000	1,740	4,350	6.50	165	0.346	8.8	

- Notes: ■ 1 indicates: Operating speed must be equal or less than permissible speed which is limited by the weight and critical speed of the spacer.
 ■ 2 indicates: For higher speeds contact Lovejoy Technical Support.
 ■ 3 indicates: The maximum bores shown are for cylindrical or taper shafts with keys. For splines and other types of bores, contact Lovejoy Technical Support.
 ■ 4 indicates: Axial misalignment is given for two disc packs.
 ■ 5 indicates: Angular misalignment is given for one disc pack.

**SXCST-6 (Close Coupled Split Spacer)
 Dimensional Data**

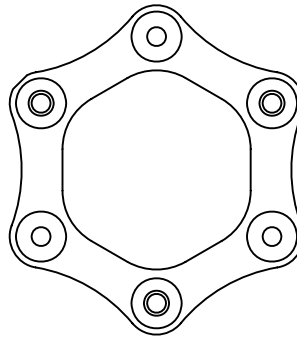
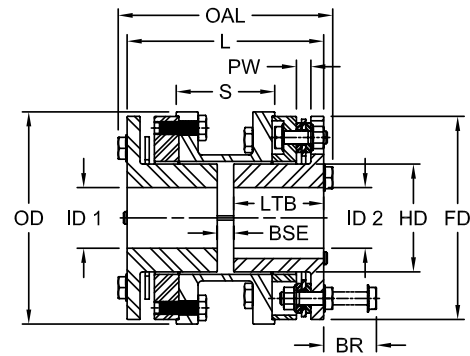
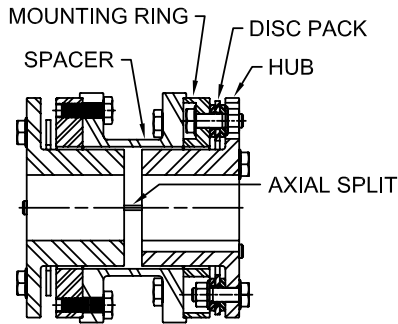

SXCST-6 Dimensional Data

Size	OAL		L		PW		S		LTB		BSE ⁷ Standard		BR		FD		HD		OD	
	in	mm	in	mm	in	mm	in	mm	in	mm	in	mm	in	mm	in	mm	in	mm	in	mm
90-6	3.92	99.6	3.60	91.4	0.295	7.5	1.83	46.5	1.57	40	0.46	11.6	1.77	45	3.54	89.9	1.67	42.4	3.70	94.0
110-6	5.06	128.5	4.62	117.3	0.331	8.4	2.27	57.5	1.97	50	0.68	17.2	1.77	45	4.33	110.0	2.13	54.1	4.53	121.2
132-6	5.54	140.7	5.10	129.7	0.331	8.4	2.75	69.9	2.36	60	0.38	9.7	1.77	45	5.20	132.1	2.79	70.9	5.47	138.9
158-6	6.58	167.0	6.02	152.9	0.441	11.2	3.02	76.7	2.76	70	0.50	12.7	2.17	55	6.22	158.0	3.31	84.1	6.50	165.1
185-6	8.15	207.2	7.53	191.2	0.551	14.0	3.88	98.5	3.15	80	1.23	31.2	2.56	65	7.28	184.9	3.74	95.0	7.60	193.0
202-6	8.76	222.5	8.06	204.7	0.610	15.5	4.01	101.9	3.53	90	1.00	25.4	2.95	75	7.95	201.9	4.25	108.0	8.27	210.1
228-6	10.06	255.6	9.28	235.7	0.689	17.5	4.68	118.9	3.94	100	1.40	35.6	3.35	85	8.98	228.1	4.84	122.9	9.29	236.0
255-6	12.29	312.2	11.27	286.3	0.807	20.5	5.57	141.5	4.52	115	2.23	56.6	3.94	100	10.04	255.0	5.30	134.6	10.35	262.9
278-6	12.31	312.7	11.29	286.8	0.835	21.2	5.53	140.5	4.91	125	1.47	37.3	4.13	105	10.95	278.1	5.99	152.1	11.26	286.0
302-6	13.93	353.8	12.81	325.6	0.961	24.4	6.40	162.6	5.31	135	2.19	55.6	4.53	115	11.88	301.8	6.49	164.8	12.20	309.9
325-6	13.62	346.0	12.52	318.0	1.020	16.0	8.74	222.0	5.71	145	1.10	28.0	4.53	115	12.80	325.0	6.85	14.0	13.11	333.0
345-6	14.57	370.0	13.39	340.0	1.110	28.2	9.28	235.6	6.10	155	1.18	30.0	4.92	125	13.58	345.0	7.32	186.0	13.58	345.0
380-6	16.06	408.0	14.72	374.0	1.260	32.0	10.08	256.0	6.69	170	1.34	34.0	5.51	140	14.96	380.0	8.03	204.0	15.35	390.0
410-6	17.44	443.0	15.94	405.0	1.310	33.2	10.97	278.6	7.28	185	1.38	35.0	5.91	150	16.14	410.0	9.13	232.0	16.14	410.0
440-6	18.51	470.0	16.85	428.0	1.430	36.4	11.39	289.2	7.68	195	1.50	38.0	6.50	165	17.32	440.0	9.17	233.0	17.32	440.0

- Notes:
- 7 indicates: BSE is the distance between shaft ends and is a variable parameter.
 - Metric dimensions are rounded to the nearest 'mm' except where otherwise shown.
 - Customer is responsible for ensuring there is enough room between the coupling and equipment to install the bolts and properly torque them with a torque wrench. Additional shaft length may be required. See Disc Coupling Worksheet, page D-8 item 5.
 - ID1 – ID2 Dimensional Data on page D-20.

DI-6 Type Drop-In Center Industrial Coupling

The DI Type coupling is the standard 6 bolt coupling with two hubs and a spacer assembly that can be installed or removed without disturbing the equipment and hubs and without removing the disc packs from the spacer assembly. Custom spacer lengths can be specified for special applications. The coupling has two flex planes (one at each disc pack) so it can accommodate parallel misalignment by the angular misalignment in each disc pack. This configuration will also accommodate axial misalignment within the specified limits.

Features

- Designed to meet the API 610 Standard
- Support for additional API requirements available on request
- Unitized disc pack
- Infinite life if properly aligned
- Torsionally rigid without any back lash
- No need for lubrication or maintenance
- No wearing parts and high resistance to harsh environmental conditions

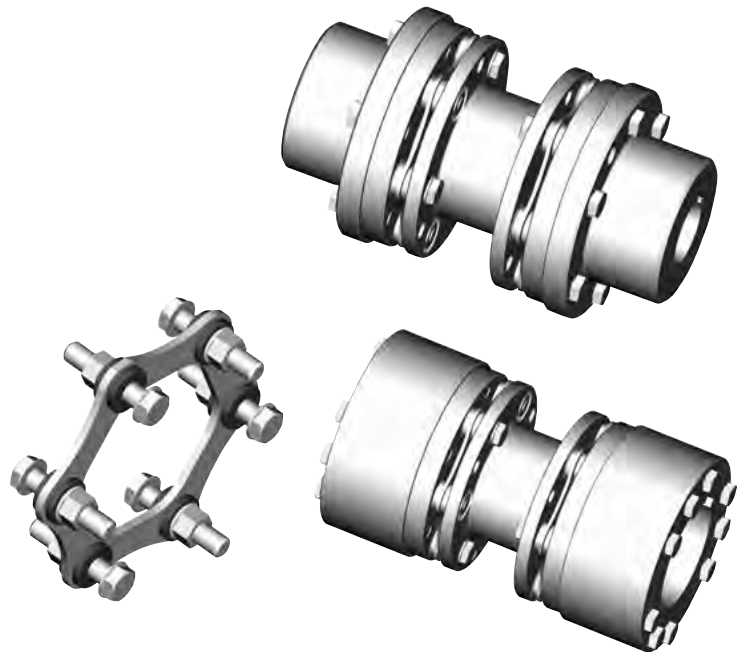

DI-6 Performance Data

Size	Nominal Torque		Peak Torque		Max Speed		ID1 - ID2				Weight ⁴		Axial ⁵ Misalignment ± ΔKa		Angular ⁶ Misalignment Max Degrees
	in-lbs	Nm	in-lbs	Nm	Unbal ¹ RPM	Bal ² RPM	Max Bore ³				lbs	kg	in	mm	
							Std Hub	Jumbo Hub							
							in	mm	in	mm					
90-6	2,100	240	4,200	480	9,100	22,700	1.68	43	2.25	59	8	4	0.059	1.5	1.5°
110-6	5,100	575	10,200	1 150	7,200	18,000	2.06	52	2.94	75	12	6	0.083	2.1	
132-6	9,700	1 100	19,500	2 200	5,840	14,600	2.69	67	3.56	90	22	10	0.102	2.6	
158-6	17,700	2 000	35,400	4 000	4,920	12,300	3.13	80	4.13	105	40	18	0.122	3.1	
185-6	29,200	3 300	58,400	6 600	4,200	10,500	3.75	95	4.94	125	62	28	0.146	3.7	
202-6	40,700	4 600	81,400	9 200	3,840	9,600	4.06	102	5.38	135	84	38	0.150	3.8	1°
228-6	62,000	7 000	123,900	14 000	3,400	8,500	4.50	115	5.94	150	121	55	0.165	4.2	
255-6	90,300	10 200	180,600	20 400	3,080	7,700	4.94	125	6.63	170	159	72	0.185	4.7	
278-6	125,700	14 200	251,400	28 400	2,800	7,000	5.50	140	7.31	185	223	101	0.205	5.2	
302-6	177,000	20 000	354,000	40 000	2,560	6,400	6.13	155	7.88	200	293	133	0.224	5.7	
325-6	221,300	25 000	442,600	50 000	2,400	6,000	6.75	170	8.44	215	353	160	0.256	6.5	
345-6	274,400	31 000	549,000	62 000	2,200	5,500	7.13	180	9.13	230	425	193	0.272	6.9	
380-6	374,400	42 300	749,000	84 600	2,040	5,100	8.31	210	9.88	250	578	262	0.299	7.6	
410-6	505,400	57 100	1,011,000	114 200	1,880	4,700	8.88	225	10.63	270	739	335	0.323	8.2	
440-6	650,500	73 500	1,301,000	147 000	1,740	4,350	9.25	235	11.44	290	875	397	0.346	8.8	

- Notes:
- 1 indicates: Operating speed must be equal or less than permissible speed which is limited by the weight and critical speed of the spacer.
 - 2 indicates: Couplings as manufactured can accommodate maximum speeds as listed. Higher speeds up to the value shown as 'Bal' require special balancing.
 - 3 indicates: The maximum bores shown are for cylindrical or taper shafts with keys. For splines and other types of bores, contact Lovejoy Technical Support.
 - 4 indicates: Weight is given for a complete coupling with maximum bores.
 - 5 indicates: Axial misalignment is given for two disc packs.
 - 6 indicates: Angular misalignment is given for one disc pack.

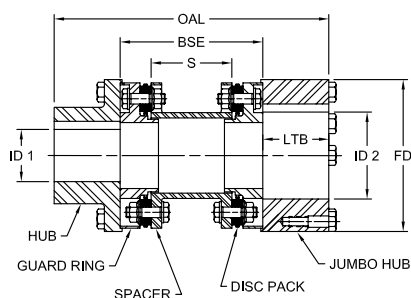
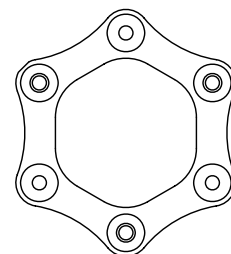
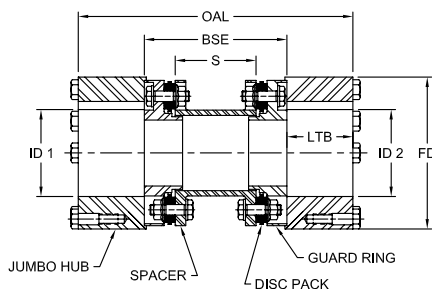
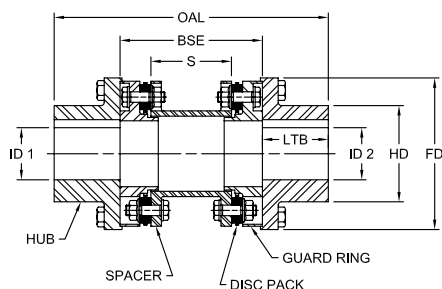

Standard BSE Sizes

Size	3.1 in	3.5 in	4.38 in	5 in	5.5 in	7 in	7.5 in	8 in	9 in
90-6	●	●	●	●	●	●			
110-6		●	●	●	●	●			
132-6		●	●	●	●	●			
158-6			●	●	●	●			
185-6				●	●	●	●	●	●
202-6					●	●	●	●	●
228-6						●	●	●	●
255-6							●	●	●
278-6							●	●	●
302-6									●

DI-6 Dimensional Data

Size	OAL		BSE		S		LTB		BSE Standard See Note		FD		HD		ID1 - ID2			
	in	mm	in	mm	in	mm	in	mm	in	mm	in	mm	in	mm	Max Bore ³			
															Std Hub		Jumbo Hub	
in	mm	in	mm	in	mm	in	mm	in	mm	in	mm	in	mm	in	mm	in	mm	
90-6	6.25	159	3.11	79	1.27	32	1.57	40	3.11	79	3.70	94	2.36	60	1.68	43	2.25	59
110-6	8.19	208	4.25	108	2.41	61	1.97	50	4.25	108	4.53	115	2.87	73	2.06	52	2.94	75
132-6	9.10	231	4.38	111	2.54	64	2.36	60	4.38	111	5.47	139	3.74	95	2.69	67	3.56	90
158-6	11.02	280	5.50	140	3.12	79	2.76	70	5.50	140	6.50	165	4.41	112	3.13	80	4.13	105
185-6	12.61	320	6.31	160	3.48	88	3.15	80	6.31	160	7.60	193	5.28	134	3.75	95	4.94	125
202-6	14.39	366	7.31	186	4.12	105	3.54	90	7.31	186	8.27	210	5.67	144	4.06	102	5.38	135
228-6	15.94	405	8.06	205	4.48	114	3.94	100	8.06	205	9.29	236	6.30	160	4.50	115	5.94	150
255-6	18.94	481	9.88	251	5.51	140	4.53	115	9.88	251	10.35	263	6.89	175	4.94	125	6.63	170
278-6	19.90	505	10.06	256	5.63	143	4.92	125	10.06	256	11.26	286	7.68	195	5.50	140	7.31	185
302-6	21.68	551	11.06	281	6.15	156	5.32	135	11.06	281	12.20	310	8.40	213	6.13	155	7.88	200
325-6	22.67	576	11.25	286	6.21	158	5.71	145	11.25	286	13.11	333	9.45	240	6.75	170	8.44	215
345-6	24.83	631	12.63	321	7.18	182	6.10	155	12.63	321	13.98	355	10.04	255	7.13	180	9.13	230
380-6	27.01	686	13.63	346	7.49	190	6.70	170	13.63	346	15.35	390	11.61	295	8.31	210	9.88	250
410-6	29.31	744	14.75	375	8.12	206	7.28	185	14.75	375	16.54	420	12.40	315	8.88	225	10.63	270
440-6	31.74	806	16.38	416	9.10	231	7.68	195	16.38	416	17.72	450	12.99	330	9.25	235	11.44	290

- Notes: ■ 3 indicates: The maximum bores shown are for cylindrical or taper shafts with keys. For splines and other type bores, contact Lovejoy Technical Support.
 ■ Metric dimensions are rounded to the nearest 'mm' except where otherwise shown.
 ■ Custom spacer sizes are available in both longer and shorter lengths. For a list of standard spacer sizes, see page D-27.

DI-8 (API Style Drop-In Spacer) Performance Data

DI-8 Type Drop-In Center Industrial Coupling

The DI Type coupling is the standard 6 bolt coupling with two hubs and a spacer assembly that can be installed or removed without disturbing the equipment and hubs and without removing the disc packs from the spacer assembly. The coupling has two flex planes (one at each disc pack) so it can accommodate parallel misalignment by the angular misalignment in each disc pack. This configuration will also accommodate axial misalignment within the specified limits.

Features

- Designed to meet the API 610 Standard
- Support for additional API requirements available on request
- Unitized disc pack
- Infinite life if properly aligned
- Torsionally rigid without any back lash
- No need for lubrication or maintenance
- No wearing parts and high resistance to harsh environmental conditions
- Puller holes standard with this design

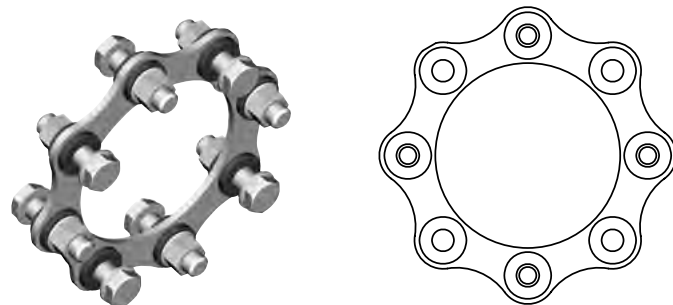
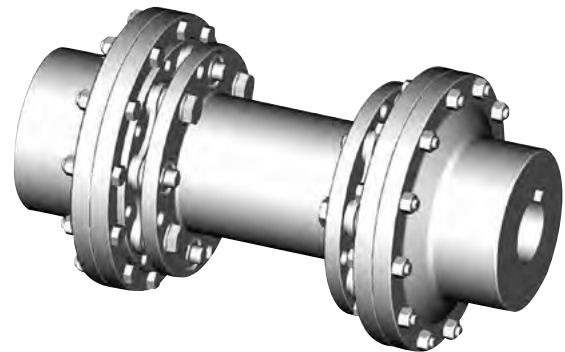

DI-8 Performance Data

Size	Nominal Torque		Peak Torque		Max Speed		ID1 - ID2				Weight ⁴		Axial ⁵ Misalignment		Angular ⁶ Misalignment
							Max Bore ³								
							Unbal ¹		Bal ²						
in-lbs	Nm	in-lbs	Nm	RPM	RPM	in	mm	in	mm	lbs	kg	in	mm	Max Degrees	
278-8	177,000	20 000	354,000	40 000	2,800	7,000	5.50	140	7.31	185	287	130	0.146	3.7	1/2°
302-8	265,500	30 000	531,000	60 000	2,560	6,400	6.13	155	7.88	200	362	164	0.157	4.0	
325-8	327,500	37 000	655,000	74 000	2,400	6,000	6.75	170	8.50	215	470	213	0.169	4.3	
345-8	407,100	46 000	814,000	92 000	2,200	5,500	7.13	180	9.06	230	551	250	0.181	4.6	
380-8	557,500	63 000	1,115,000	126 000	2,040	5,100	8.31	210	10.13	255	717	325	0.197	5.0	
410-8	761,000	86 000	1,522,000	172 000	1,880	4,700	8.88	225	10.94	275	908	412	0.213	5.4	
440-8	973,500	110 000	1,947,000	220 000	1,740	4,350	9.25	235	11.88	300	1,058	480	0.228	5.8	
475-8	1,221,000	138 000	2,443,000	276 000	1,680	4,200	9.94	250	12.63	320	1,393	632	0.248	6.3	
505-8	1,549,000	175 000	3,098,000	350 000	1,520	3,800	10.88	275	13.44	341	1,750	794	0.264	6.7	
540-8	1,947,000	220 000	3,894,000	440 000	1,440	3,600	11.63	295	14.25	360	1,852	840	0.283	7.2	
570-8	2,292,000	259 000	4,585,000	518 000	1,360	3,400	12.63	320	15.25	385	2,094	950	0.299	7.6	

- Notes:
- 1 indicates: Operating speed must be equal or less than permissible speed.
 - 2 indicates: Couplings as manufactured can accommodate maximum speeds as listed. Higher speeds up to the value shown as 'Bal' require special balancing.
 - 3 indicates: The maximum bores shown are for cylindrical or taper shafts with keys. For splines and other type bores, contact Lovejoy Technical Support.
 - 4 indicates: Weight is given for a complete coupling with maximum bores.
 - 5 indicates: Axial misalignment is given for two disc packs.
 - 6 indicates: Angular misalignment is given for one disc pack.

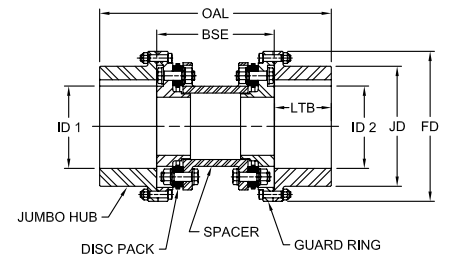
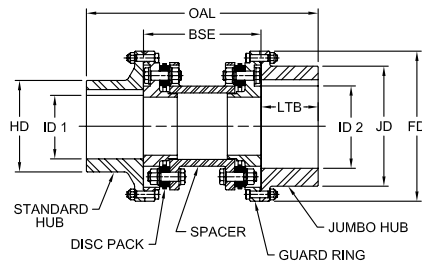
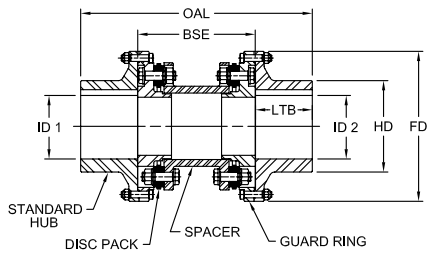

DI-8 Dimensional Data

Size	OAL		BSE		LTB		ID1 - ID2				FD		HD		JD	
	in	mm	in	mm	in	mm	Max Bore ³				in	mm	in	mm	in	mm
							Std Hub		Jumbo Hub							
							in	mm	in	mm						
278-8	19.90	505	10.06	256	4.92	125	5.50	140	7.31	185	13.07	332	7.68	195	10.24	260
302-8	21.70	551	11.06	281	5.32	135	6.13	155	7.88	200	14.02	356	8.54	217	11.22	285
325-8	22.67	576	11.25	286	5.71	145	6.75	170	8.50	215	15.75	400	9.45	240	12.01	305
345-8	24.83	631	12.63	321	6.10	155	7.13	180	9.06	230	16.42	417	10.04	255	12.68	322
380-8	27.01	686	13.63	346	6.69	170	8.31	210	10.13	255	17.91	455	11.61	295	14.17	360
410-8	29.31	744	14.75	375	7.28	185	8.88	225	10.94	275	19.60	498	12.40	315	15.35	390
440-8	31.74	806	16.38	416	7.68	195	9.25	235	11.88	300	20.79	528	12.99	330	16.54	420
475-8	34.26	870	17.75	451	8.27	210	9.94	250	12.63	320	23.03	585	13.98	355	17.72	450
505-8	37.43	951	19.31	490	9.06	230	10.88	275	13.44	341	24.21	615	15.16	385	18.90	480
540-8	40.96	1 040	22.06	560	9.45	240	11.63	295	14.25	360	26.38	670	16.34	415	20.00	508
570-8	43.56	1 106	23.88	607	9.84	250	12.63	320	15.25	385	27.64	702	17.72	450	21.26	540

- Notes: ■ 3 indicates: The maximum bores shown are for cylindrical or taper shafts with keys. For splines and other type bores, contact Lovejoy Technical Support.
 ■ Metric dimensions are rounded to the nearest 'mm' except where otherwise shown.

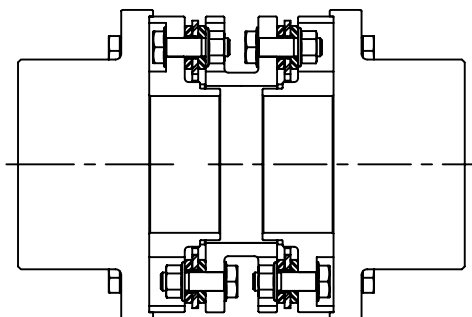

Please Note, Lovejoy DI-6 and DI-8 Type Drop-In Spacer style couplings are specially piloted to provide anti-flail protections and prevent the spacer from coming out of the coupling if the disc packs or bolts fail.

DIR-6 and DILR-6 Type Drop-In Center

The DIR and DILR Type coupling is designed to be a direct replacement for floating shafts in flanged series floating shaft gear couplings. The DIR is provided with F-Style rigid gear coupling hubs and the DILR can be manufactured to work with existing rigid hubs without disturbing or moving the equipment. All spacers are manufactured to the customer's specified length and are sized using a service factor of 2.0. The coupling has two flex planes (one at each disc pack) so it can accommodate parallel misalignment by the angular misalignment in each disc pack and it is suitable for axial displacement within specified limits. DILR Type couplings are manufactured slightly shorter than the DBFF dimension specified by the customer and shims are provided to aid in simplifying the installation.

Features

- No need for lubrication or maintenance
- Can utilize existing rigid Flanged Gear hubs or custom paper machine hubs (Beloit and Voith)
- Can be inspected while in operation
- Can run at higher speeds than floating shaft gear couplings
- Unitized disc pack
- Infinite life if properly aligned
- Torsionally rigid with minimal back lash
- No wearing parts and high resistance to harsh environmental conditions
- Shim kits are standard for ease of installation and precise spacer positioning
- Anti Flail / Anti Fly piloting option is standard to prevent the spacer assembly from flying out if a disc pack and bolts fail
- Adjustable lengths using shaft locking devices

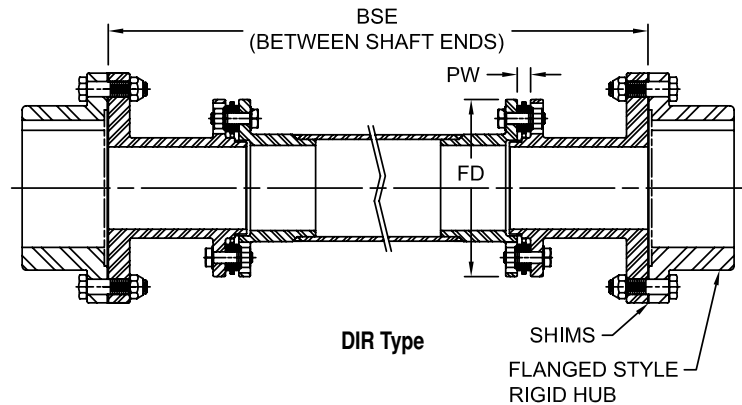
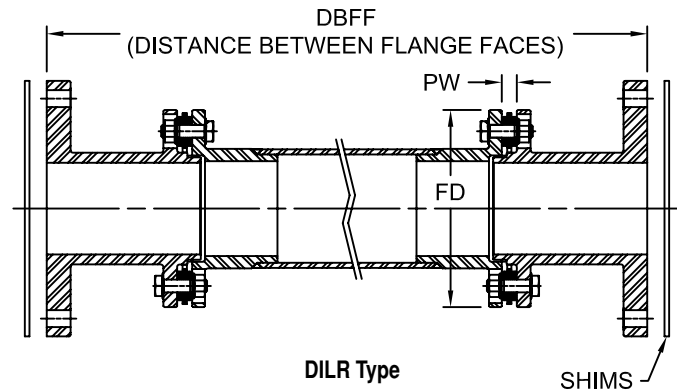

Selection Process for DIR, DIRA, DILR, and DILRA Disc Couplings

The DILR and DILRA Type coupling are a direct replacement for a floating shaft style gear coupling. The DILR/DILRA is designed to utilize the hubs already on the customer's equipment. The DILR drop in replacement will be manufactured slightly shorter than the DBFF and shims will be used for ease of maintenance. The DILRA is adjustable using an SLD (Shaft Locking Device) to make axial or length adjustments. Customers with multiple pieces of equipment with similar length couplings can stock one spare spacer that can be used as a replacement for more than one coupling.

If the end user requires rigid hubs be provided with the coupling, a DIR or DIRA Type coupling will be recommended and the BSE (distance Between Shaft Ends) must be specified.

Required Information:

The end user should be prepared to provide the following information when contacting Lovejoy Technical Support:

- Motor horse power and speed (include gearbox ratio – input and output).
- Rigid hub sizes (if the customer is using existing F-Style rigid gear coupling hubs).
- DBFF or distance between flange faces of the rigid hubs for DILR Type.
- BSE shaft separation can be specified for DIR Type.
- Shaft sizes for rigid hubs DIR and DIRA Type couplings.
- For maximum bore sizes, consult with Lovejoy Gear Coupling Catalog pages F-Style rigid hubs.

DIRA-6 and DILRA-6 Type

Drop-In Center

The DIRA and DILRA Type couplings are designed to be direct replacements for floating shafts in flanged series floating shaft gear couplings. This type uses existing or Lovejoy supplied rigid F-Style gear coupling hubs. The DIRA/DILRA are similar to the DIR and DILR Types with the exception these incorporate the use of an SLD shaft locking device to make length adjustments instead of shims. The standard axial adjustment is +/- 2.0 inches for this type of coupling. Custom length adjustment amounts can be provided on request. The DIRA is provided with rigid hubs. The DILRA can be manufactured to serve as a direct drop in replacement for use with existing rigid hubs without disturbing or moving the equipment. All spacers are manufactured to the customer's specified length and are sized using a service factor of 2.0. The coupling has two flex planes (one at each disc pack) so it can accommodate parallel misalignment by the angular misalignment in each disc pack and it is suitable for axial displacement within specified limits.

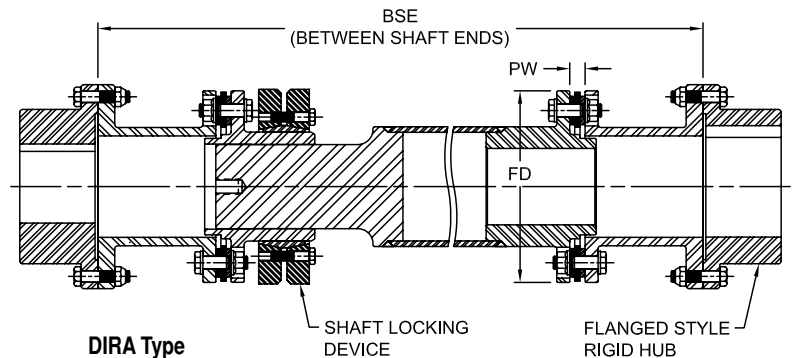
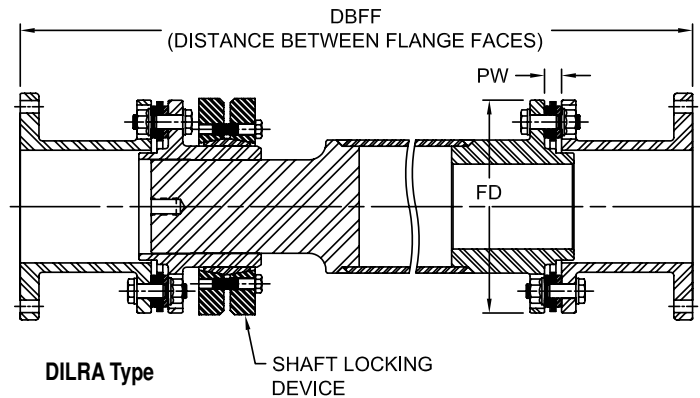

DIR / DILR - 6 Performance and Dimensional Data

Size	Nominal Torque		Peak Torque		Max Speed RPM	FD		PW		Axial Misalignment $\pm \Delta K_a$		Angular Misalignment Degrees
	in-lb	Nm	in-lb	Nm		in	mm	in	mm	in	mm	
132-6	9,700	1 100	19,500	2 200	Maximum Speed is determined by the length and critical speed of the spacer assembly	5.20	132	0.331	8.4	0.102	2.6	1.5°
158-6	17,700	2 000	35,400	4 000		6.22	158	0.441	11.2	0.122	3.1	
185-6	29,200	3 300	58,400	6 600		7.28	185	0.551	14.0	0.146	3.7	
202-6	40,700	4 600	81,400	9 200		7.95	202	0.610	15.5	0.150	3.8	1°
228-6	62,000	7 000	123,900	14 000		8.98	228	0.689	17.5	0.165	4.2	
255-6	90,300	10 200	180,600	20 400		10.04	255	0.807	20.5	0.185	4.7	
278-6	125,700	14 200	251,400	28 400		10.94	278	0.835	21.2	0.205	5.2	
302-6	177,000	20 000	354,000	40 000		11.89	302	0.961	24.4	0.224	5.7	
325-6	221,300	25 000	442,600	50 000		12.80	325	1.024	26.0	0.256	6.5	
345-6	274,400	31 000	549,000	62 000		13.58	345	1.110	28.2	0.272	6.9	
380-6	374,400	42 300	749,000	84 600		14.96	380	1.260	32.0	0.299	7.6	
410-6	505,000	57 100	1,011,000	114 200		16.14	410	1.307	33.2	0.323	8.2	
440-6	651,000	73 500	1,301,000	147 000		17.32	440	1.433	36.4	0.346	8.8	

Note: ■ Axial misalignment is given for two disc packs, angular misalignment is given for one disc pack.

Various Examples

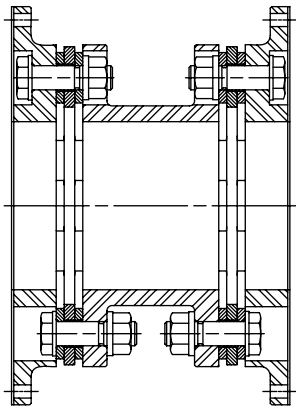

SXFA Type with Flanges

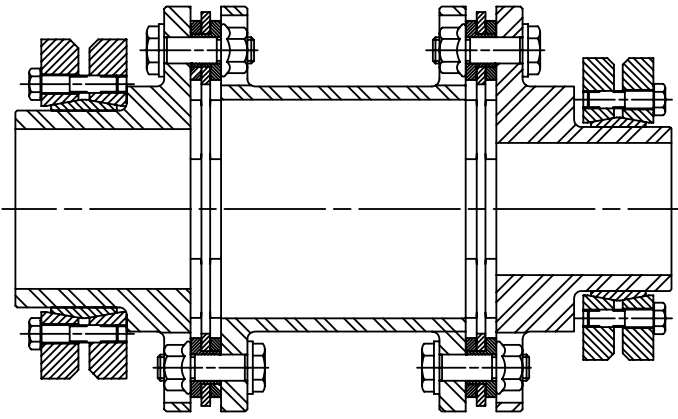

SX Type with SLD Shaft Locking Device

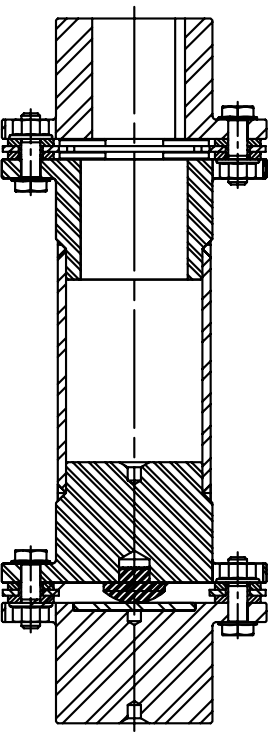

SXV Type for Vertical Mounting

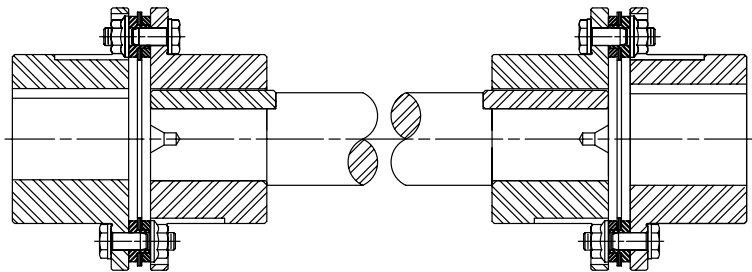

SXFS Type with Floating Shaft

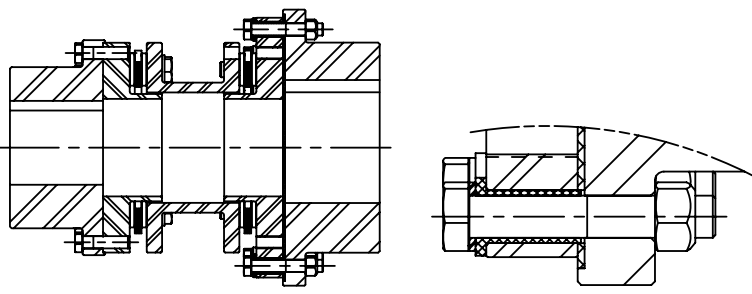

DIEI Type with Electrical Insulation

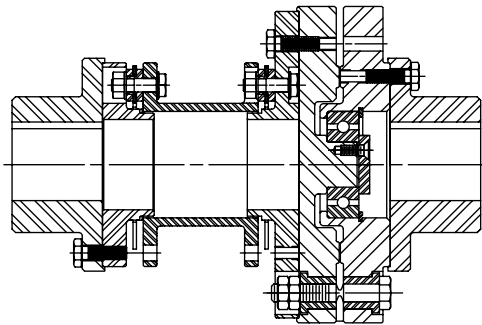

DISP Type with Shear Pins

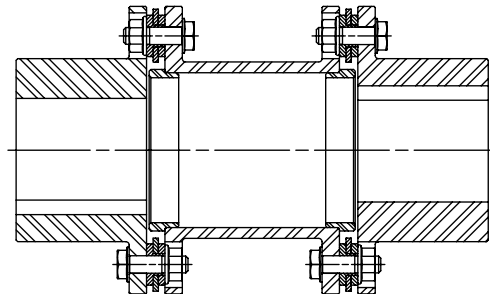

SXLEF Type with LEF Limited End Float

D