

MRA-RTU-2-00-000-

ENTER X-AXIS TRAVEL
TRAVEL IN INCREMENTS OF 250mm
TRAVEL LIMITS: 250mm-5325mm*

*IF TRAVEL IS
OUTSIDE LIMITS
LISTED, CONTACT
MACRON*

GEARBOX MODEL

VC-T-090-____

RATIO: _____

MOTOR INFORMATION

MANUFACTURER: _____

MODEL: _____

SENSOR INFORMATION X-AXIS:

HOME-QTY ____ 244-____-____-____

EOT-QTY ____ 244-____-____-____

(SEE T-SLOT SENSOR KIT SHEET FOR
PART NUMBER CONFIGURATION)

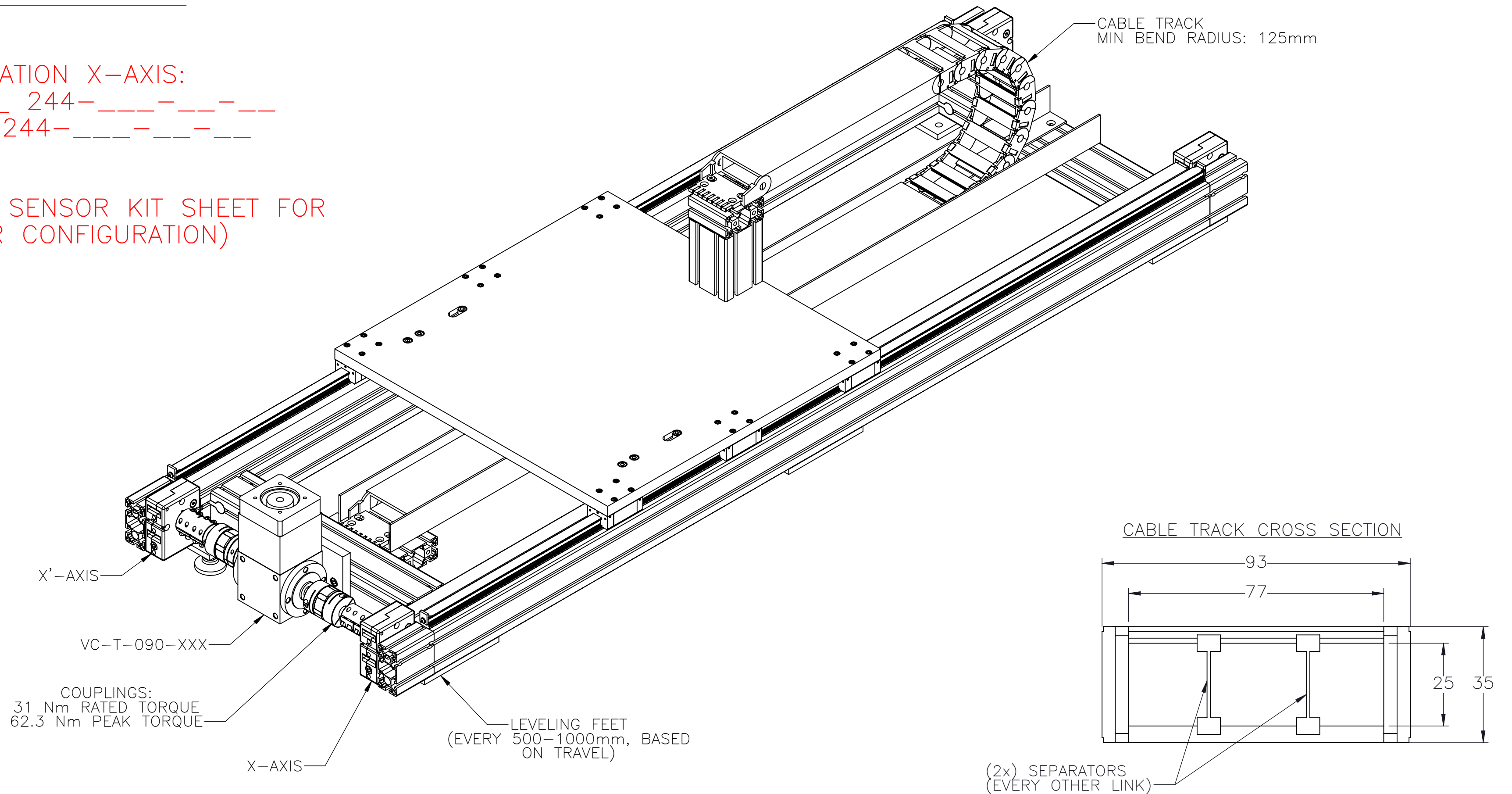

APPROVED: _____

DATE: _____

PO:REFERENCE#: _____

 MACRON DYNAMICS INC	DRAWN BY: JA DATE: 2/27/2020	MATERIAL:	TITLE: MACRON RTU SYSTEM
	CHECKED BY: -- DATE: DD/MM/YYYY	FINISH:	
	LAST SAVED BY: Tim DATE: 12/21/2021	UNLESS OTHERWISE SPECIFIED, DIMENSIONS ARE IN MILLIMETERS. TOLERANCES UNLESS NOTED OTHERWISE:	SCALE 1:1 SHEET SIZE C
	SURFACE FINISH \checkmark	BREAK ALL SHARP EDGES DIMENSIONAL LIMITS APPLY AFTER FINISHING THIRD ANGLE PROJECTION	SHEET 1 OF 5 PART NUMBER MRA-RTU-2-00-000-XXXXX

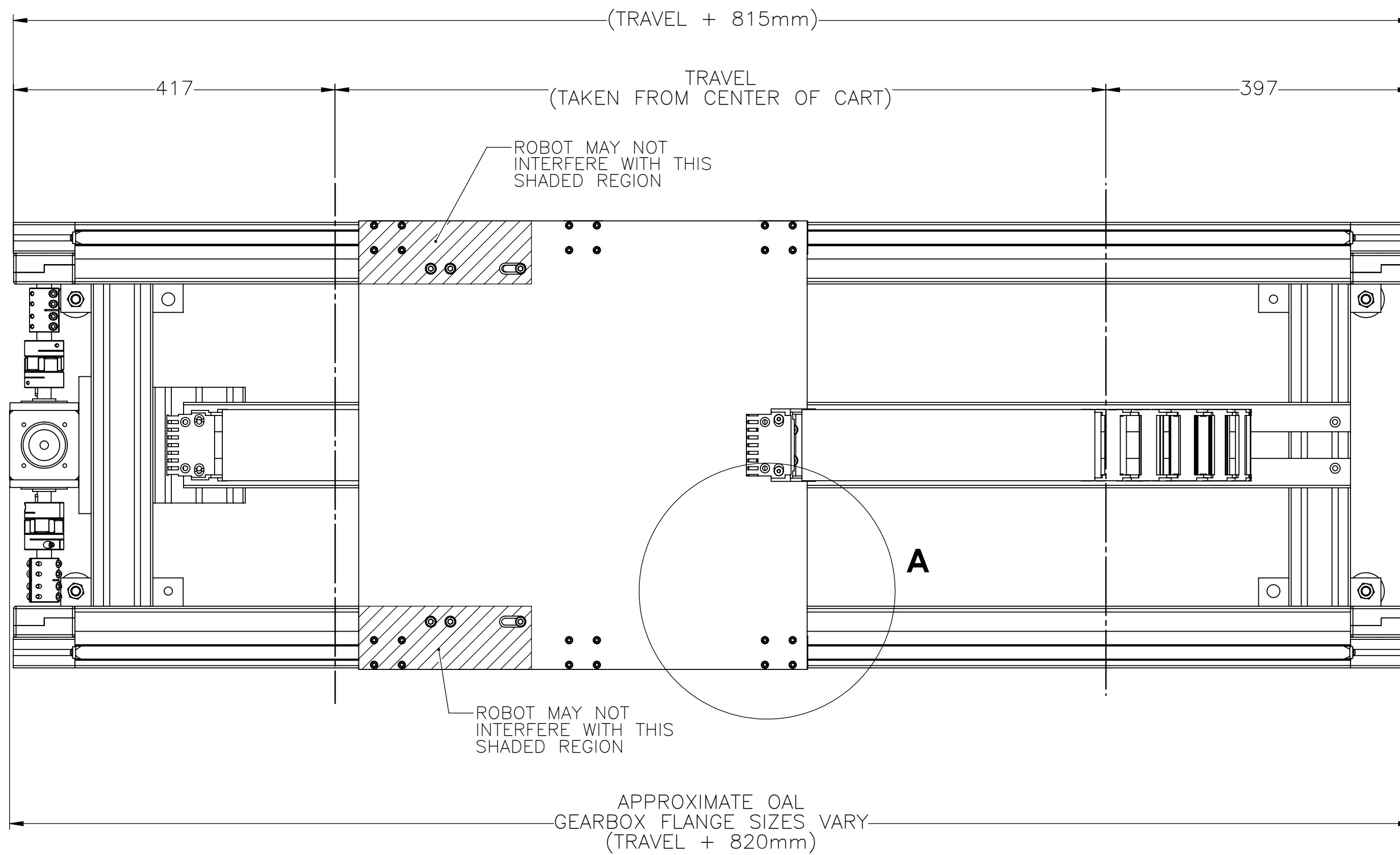

ROBOT TRANSPORT PLATE HIDDEN TO SHOW CROSSBEAM UNDERNEATH. CROSSBEAMS AND LEVELING FEET ARE PLACED EVERY 500-1000mm DEPENDING ON OVERALL LENGTH OF SYSTEM.

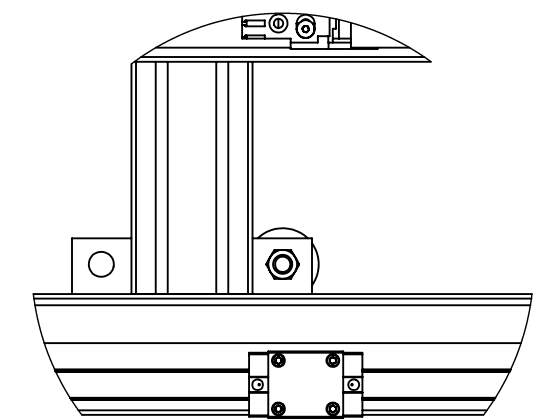

DETAIL A

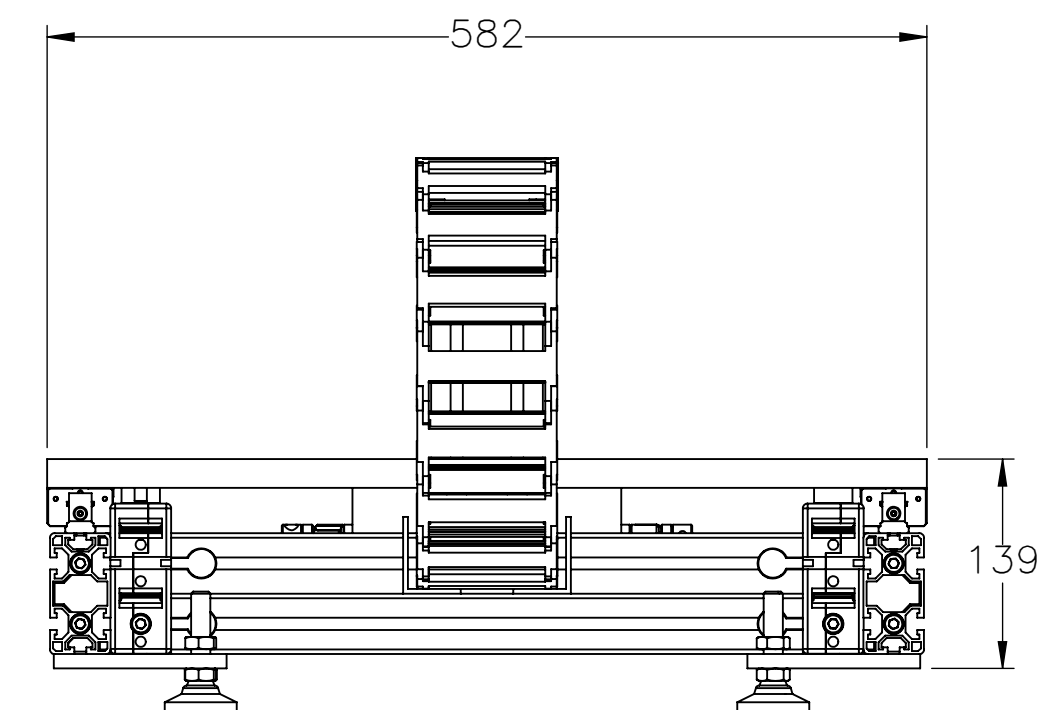
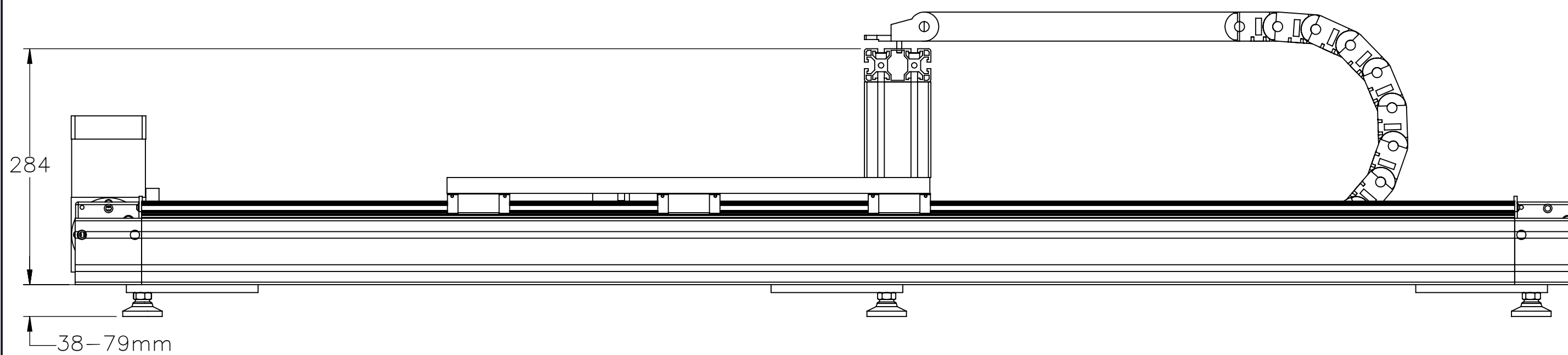

 MACRON DYNAMICS INC	DRAWN BY: JA CHECKED BY: -- LAST SAVED BY: Tim	DATE: 2/27/2020 DATE: DD/MM/YYYY DATE: 12/21/2021	MATERIAL: FINISH:	TITLE: MACRON RTU SYSTEM	
	<small>UNLESS OTHERWISE SPECIFIED, DIMENSIONS ARE IN INCHES. TOLERANCES UNLESS NOTED OTHERWISE:</small>		.X ± .03 .XX ± .010 .XXX ± .005 ANG ± 0°30'	SCALE 1:1 SHEET SIZE C	
	SURFACE FINISH 63		SHEET 2 OF 5	PART NUMBER MRA-RTU-2-00-000-XXXXX	REV
	<small>THIS DRAWING IS THE PROPERTY OF MACRON DYNAMICS. ANY REPRODUCTIONS SHALL BE FOR QUOTATION, MANUFACTURING, OR PURCHASING PURPOSES ONLY. RELEASE OF DRAWINGS TO OTHER CONCERNS DOES NOT CONSTITUTE LICENSING IN ANY WAY. INFORMATION CONTAINED HEREIN IS PROPRIETARY AND CONFIDENTIAL.</small>		BREAK ALL SHARP EDGES DIMENSIONAL LIMITS APPLY AFTER FINISHING THIRD ANGLE PROJECTION		

GANTRY MOUNTING FEATURES

ROBOT MOUNTING BOLT PATTERN WILL BE PUT IN PLATE WHEN CUSTOMER PROVIDES A BOLT PATTERN

MOUNTING PLATE CAN BE REVERSED TO OUTSIDE OF ASSEMBLY AS WELL

9/16" DIAMETER HOLE FOR ANCHOR SCREW

- MOUNTING PLATES (PRIMARY MOUNTING OPTION)
- 1x LEVELING FOOT PER PLATE (PROVIDED BY MACRON)
 - 1x 9/16" DIAMETER THROUGH HOLE PER PLATE FOR ANCHOR SCREW (ANCHOR SCREW NOT PROVIDED BY MACRON)

- MOUNTING PLATES SHOULD BE USED AS PRIMARY MOUNTING
- T-SLOTS AVAILABLE SHOULD BE USED TO MOUNT ACCESSORIES ONTO GANTRY

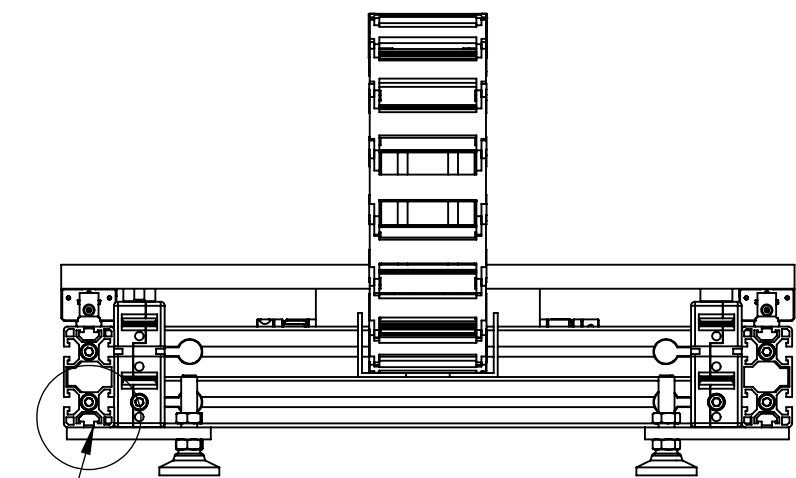
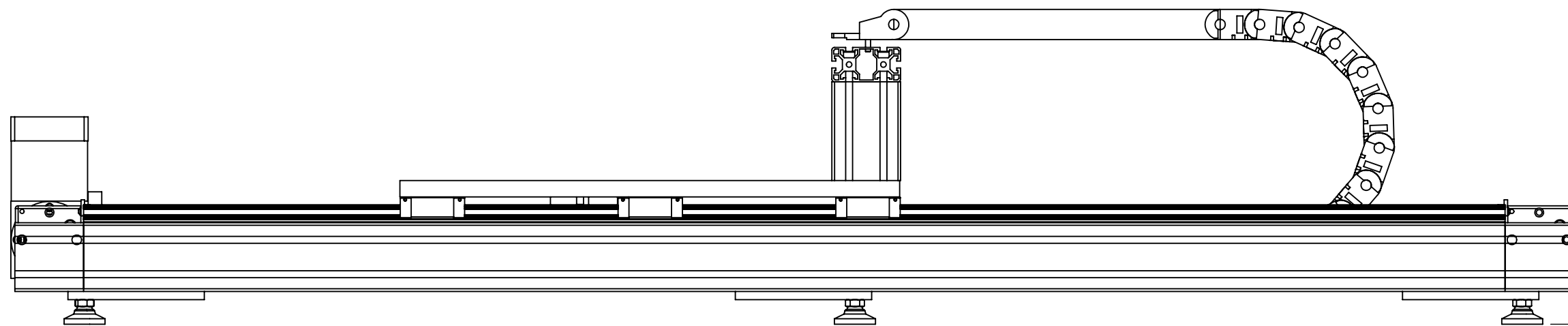
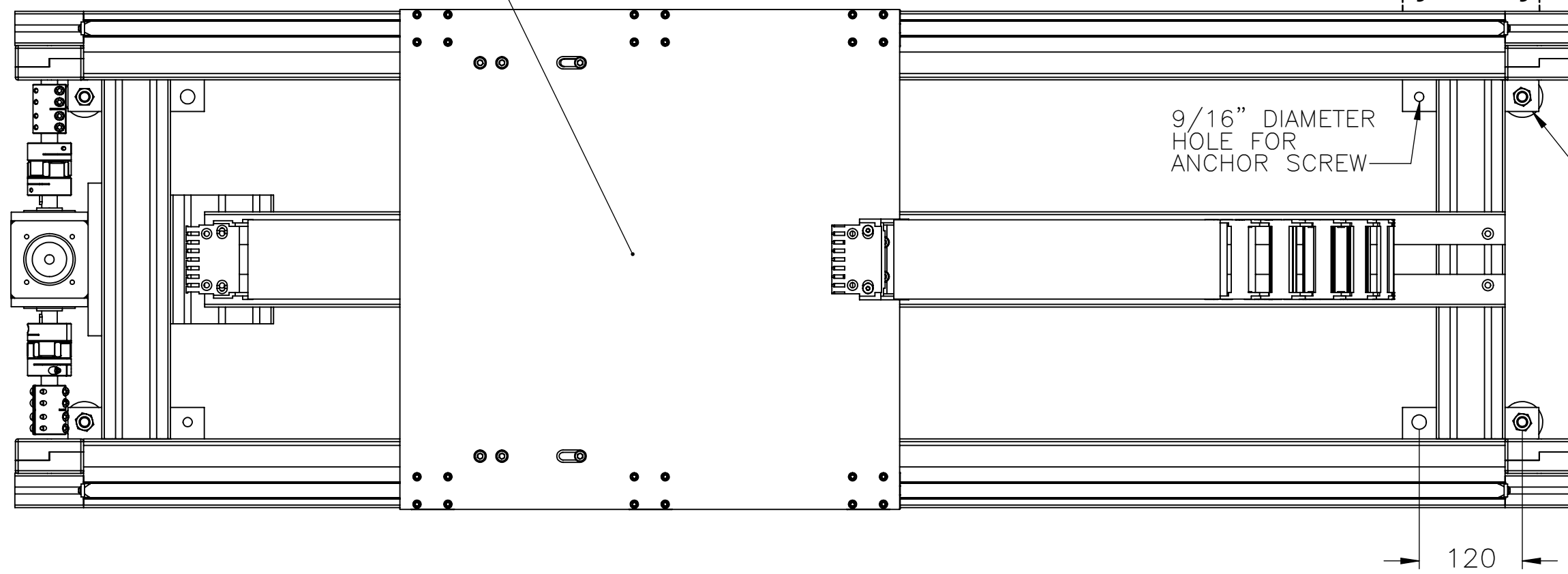

CROSSBEAMS PLACED EVERY 500-1000mm

2 T-SLOTS OPEN FOR MOUNTING (SECONDARY MOUNTING OPTION)

2 T-SLOTS OPEN FOR MOUNTING (SECONDARY MOUNTING OPTION)

T-SLOTS ON BOTTOM OF GANTRY AVAILABLE

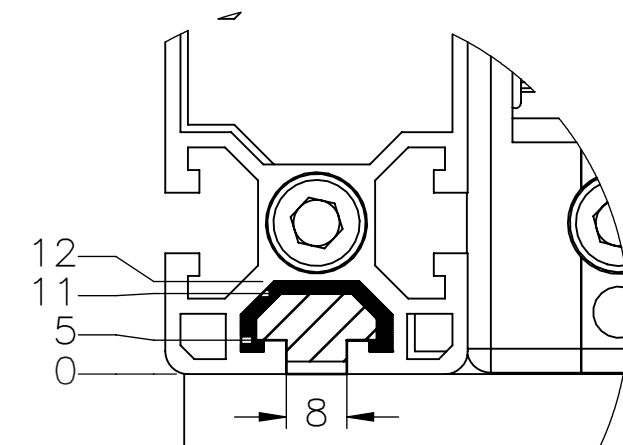
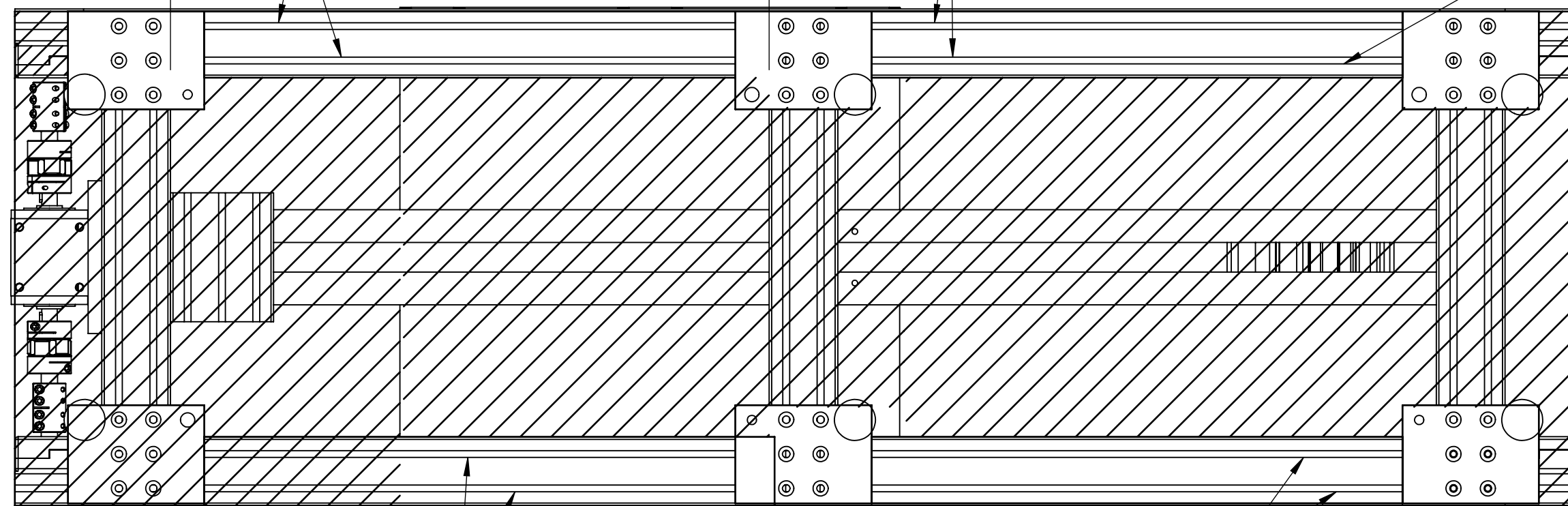

DETAIL A
VIEW OF TYPICAL T-SLOT (HEAVY SHADING)
VIEW OF TYPICAL T-NUT (LIGHT SHADING)

2 T-SLOTS OPEN FOR MOUNTING (SECONDARY MOUNTING OPTION)

2 T-SLOTS OPEN FOR MOUNTING (SECONDARY MOUNTING OPTION)

 MACRON DYNAMICS INC	DRAWN BY: JA DATE: 2/27/2020	MATERIAL:	TITLE: MACRON RTU SYSTEM
	CHECKED BY: -- DATE: DD/MM/YYYY	FINISH:	
	LAST SAVED BY: Tim DATE: 12/21/2021	UNLESS OTHERWISE SPECIFIED, DIMENSIONS ARE IN INCHES: .XX ± .010 .XXX ± .005 OTHERWISE: ANG ± 0°30'	
	SURFACE FINISH 63		
THIS DRAWING IS THE PROPERTY OF MACRON DYNAMICS. ANY REPRODUCTIONS SHALL BE FOR QUOTATION, MANUFACTURING, OR PURCHASING PURPOSES ONLY. RELEASE OF DRAWINGS TO OTHER CONCERNS DOES NOT CONSTITUTE LICENSING IN ANY WAY. INFORMATION CONTAINED HEREIN IS PROPRIETARY AND CONFIDENTIAL.		BREAK ALL SHARP EDGES DIMENSIONAL LIMITS APPLY AFTER FINISHING THIRD ANGLE PROJECTION	SHEET 3 OF 5 PART NUMBER MRA-RTU-2-00-000-XXXXX

MOTOR SIZING INFORMATION

(INCREMENTAL ADDERS REFER TO MASS PER TRAVEL LENGTH)

PROPERTY	BASE VALUE (T=250mm)
MOVING MASS	54.02kg(+0.0253kg/25mm)
BELT MASS	0.394kg(+0.0093kg/25mm)
PULLEY PITCH ϕ	47.75mm (1.88")
PULLEY WIDTH	28.9mm (1.14")
PULLEY MATERIAL	STEEL
TRAVEL PER REV	150mm
CONN SHAFT MATERIAL MASS	0.814kg

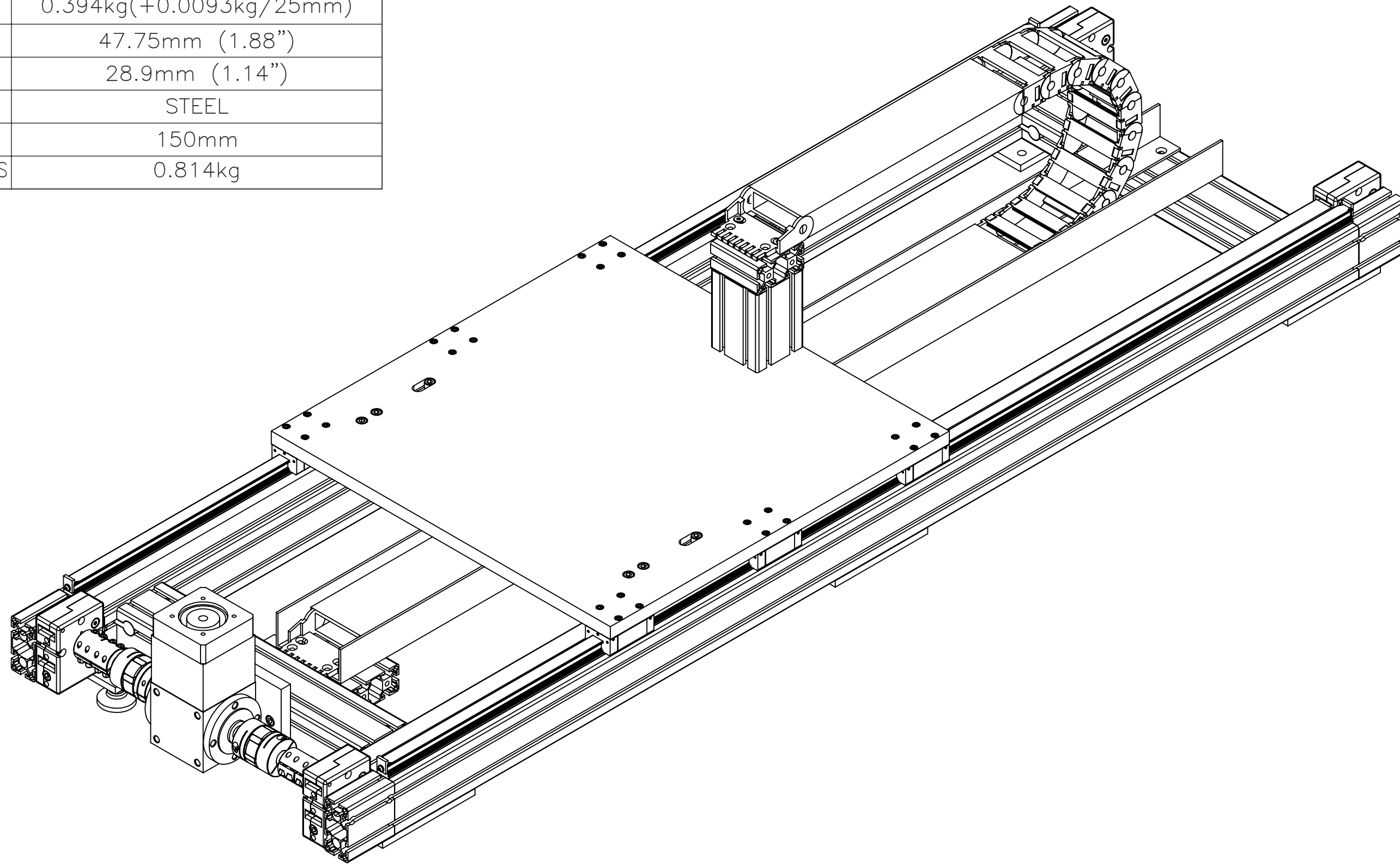

X-AXIS	MOVING MASS	(TRAVEL x 0.001) + 53.77 = kg	
	BELT MASS	[(2 x TRAVEL) x .000186] + 0.301 = kg	
 MACRON DYNAMICS INC	DRAWN BY: JA	DATE: 2/27/2020	MATERIAL:
	CHECKED BY: --	DATE: DD/MM/YYYY	TITLE: MACRON RTU SYSTEM
	LAST SAVED BY: Tim	DATE: 12/21/2021	
UNLESS OTHERWISE SPECIFIED, DIMENSIONS ARE IN INCHES. TOLERANCES UNLESS NOTED OTHERWISE:	.X ± .03	.XX ± .010	FINISH:
	.XXX ± .005	ANG ± 0°30'	
THIS DRAWING IS THE PROPERTY OF MACRON DYNAMICS. ANY REPRODUCTIONS SHALL BE FOR QUOTATION, MANUFACTURING, OR PURCHASING PURPOSES ONLY. RELEASE OF DRAWINGS TO OTHER CONCERNS DOES NOT CONSTITUTE LICENSING IN ANY WAY. INFORMATION CONTAINED HEREIN IS PROPRIETARY AND CONFIDENTIAL.	SURFACE FINISH	63	SCALE 1:1 SHEET SIZE C
	BREAK ALL SHARP EDGES DIMENSIONAL LIMITS APPLY AFTER FINISHING	THIRD ANGLE PROJECTION	SHEET 4 OF 5 PART NUMBER MRA-RTU-2-00-000-XXXXX REV

SPECIFICATIONS

Sensor Type	Inductive
Sensor Size	Fits all 8mm wide T-Slots
Operating Voltage	10–30 VDC
Voltage Drop Across Conducting Sensor	≤1.8 V at 100 mA
Number of Conductors (AWG)	3x26 AWG
Temperature Range	-40°C to 105°C

Part Number Configuration

244-_-_-_-_-_-_-_-

PNP or NPN	NC or NO	02	Meters
PNP or NPN	NC or NO	06	Meters
PNP or NPN	NC or NO	12	Meters

Example: PNP, normally closed, cord-set extension length 6 meters = 244-PNP-NC-06

PNP Diagrams

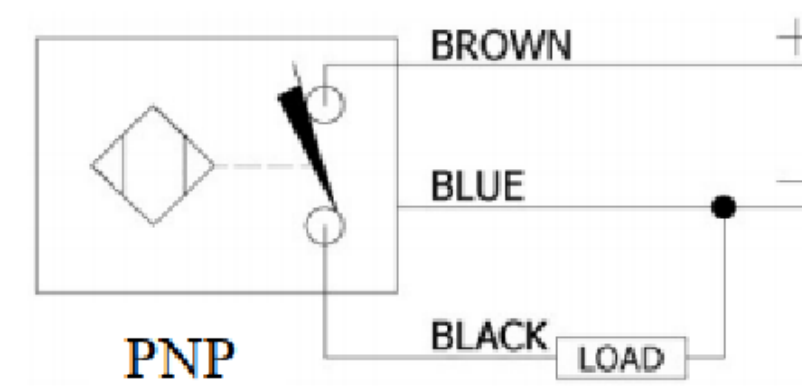
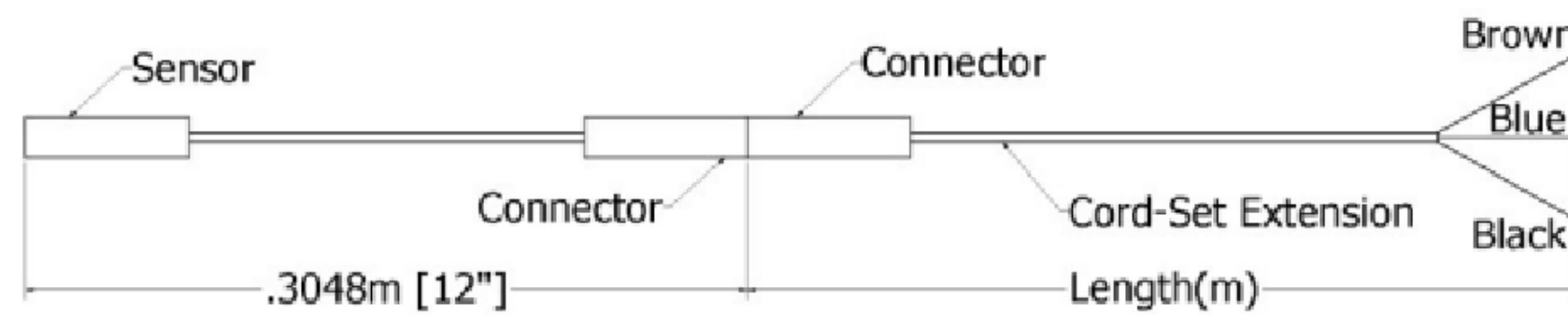

NPN Diagrams

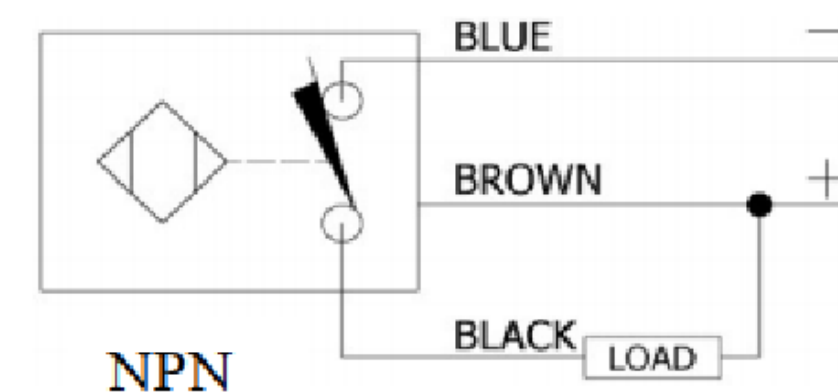
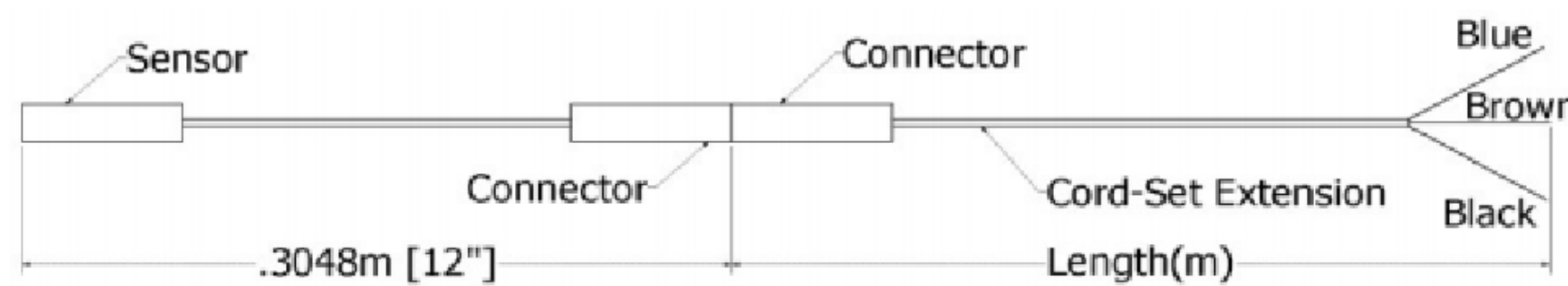

KIT INCLUDES – SENSOR, CORDSET EXTENSION, AND MOUNTING HARDWARE

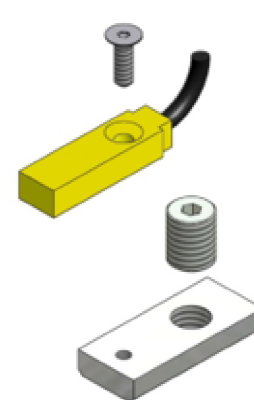
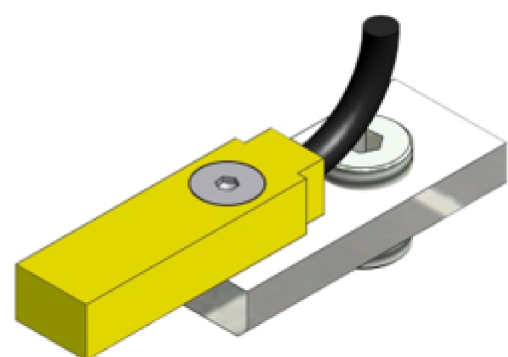

<p>MACRON DYNAMICS INC</p> <p>THIS DRAWING IS THE PROPERTY OF MACRON DYNAMICS. ANY REPRODUCTIONS SHALL BE FOR QUOTATION, MANUFACTURING, OR PURCHASING PURPOSES ONLY. RELEASE OF DRAWINGS TO OTHER CONCERNS DOES NOT CONSTITUTE LICENSING IN ANY WAY. INFORMATION CONTAINED HEREIN IS PROPRIETARY AND CONFIDENTIAL.</p>	DRAWN BY: JA CHECKED BY: -- LAST SAVED BY: JA	DATE: 2/27/2020 DATE: DD/MM/YYYY DATE: 12/21/2021	MATERIAL: FINISH:	TITLE: T-SLOT SENSOR KIT
	UNLESS OTHERWISE SPECIFIED, DIMENSIONS ARE IN MILLIMETERS. TOLERANCES UNLESS NOTED OTHERWISE:		SCALE 1:1 SHEET SIZE C	SHEET 5 OF 5
	SURFACE FINISH \checkmark		PART NUMBER	REV
	BREAK ALL SHARP EDGES DIMENSIONAL LIMITS APPLY AFTER FINISHING THIRD ANGLE PROJECTION		SENSOR CALL-OUT	