



TRANSFER POINT PRODUCTS

CONTAIN • CONTROL • ADVANCE

L3649





PROBLEM

FUGITIVE MATERIALS

Escape of materials from conveyors is an everyday occurrence. It occurs in the forms of spillage and leakage from transfer points or carryback that adheres to the belt past the discharge point and drops off along the conveyor return. It also occurs in the form of airborne dust that is carried off and settles on structures, equipment, and the ground.

Carryback falls under the conveyor, spillage falls to the sides, and dust falls on everything, including systems and structures above the conveyor. Left unchecked, fugitive materials represent an ever-increasing drain on a conveyor's efficiency, productivity, and profitability. Materials lost from the conveyor system cost the plant in a number of ways:

- Reduced operating efficiency
- Increased conveyor maintenance costs
- Reduced plant safety
- Lowered employee morale
- Diminished product quality
- Heightened scrutiny from outside agencies





SOLVED

THE MARTIN® SOLUTION

Through proper design and maintenance, bulk material handling operations can run cleanly, safely, and efficiently.

By preventing spillage and airborne dust, Martin Engineering's Transfer Point Products can help reduce equipment damage, minimize cleanup, control maintenance expenses, and improve the overall plant safety.

Martin Engineering is more than an equipment supplier. We are problem solvers dedicated to improving transfer point performance.

Problem Solved™
GUARANTEED!



A NEW STANDARD FOR CONVEYOR DESIGN

Martin Engineering has created a new standard in conveyor architecture. The modular system rethinks the problems of traditional conveyor design from the ground up and places more emphasis on safety, control of fugitive material, and ease of service.

Designed to provide a clean, safe, and productive system, the new modular conveyor architecture is cost competitive and flexible enough to be easily upgradeable to solve operation-specific problems. The modular products can be used in part or as a whole system; in conjunction with or as a complement to traditional C-Channel conveyor structure and offers a number of benefits over conventional conveyor design.

- Reduce Dust and Spillage
- Improve Safety
- Reduce Cleanup Headaches
- Improve Regulatory Compliance
- Improve Serviceability
- Simple Accessibility
- Upgradeable and Cost-Efficient



KEY COMPONENTS

(1) BELT SUPPORT

For an effective, minimum-spillage transfer point, it is essential that the belt's line of travel be stabilized with proper belt support in the load zone.

(2) SEALING SYSTEM

A crucial requirement in any transfer point designed for reduced spillage and high efficiency is an effective sealing system at the edge of the belt.

(3) BELT TRACKING

Belt tracking must be controlled before spillage can be eliminated.

(4) TAIL PULLEY PROTECTION

Pulley protection plows are installed to remove lumps and stray components from the belt before they can damage the pulley or belt.

(5) CHUTE STRUCTURE

Bulk materials should flow through a transfer chute evenly and consistently.

(6) DUST MANAGEMENT

Airborne dust is a common problem in bulk-materials handling operations. When both material spillage and airborne dust are controlled, the operation will be cleaner, safer, and more productive.

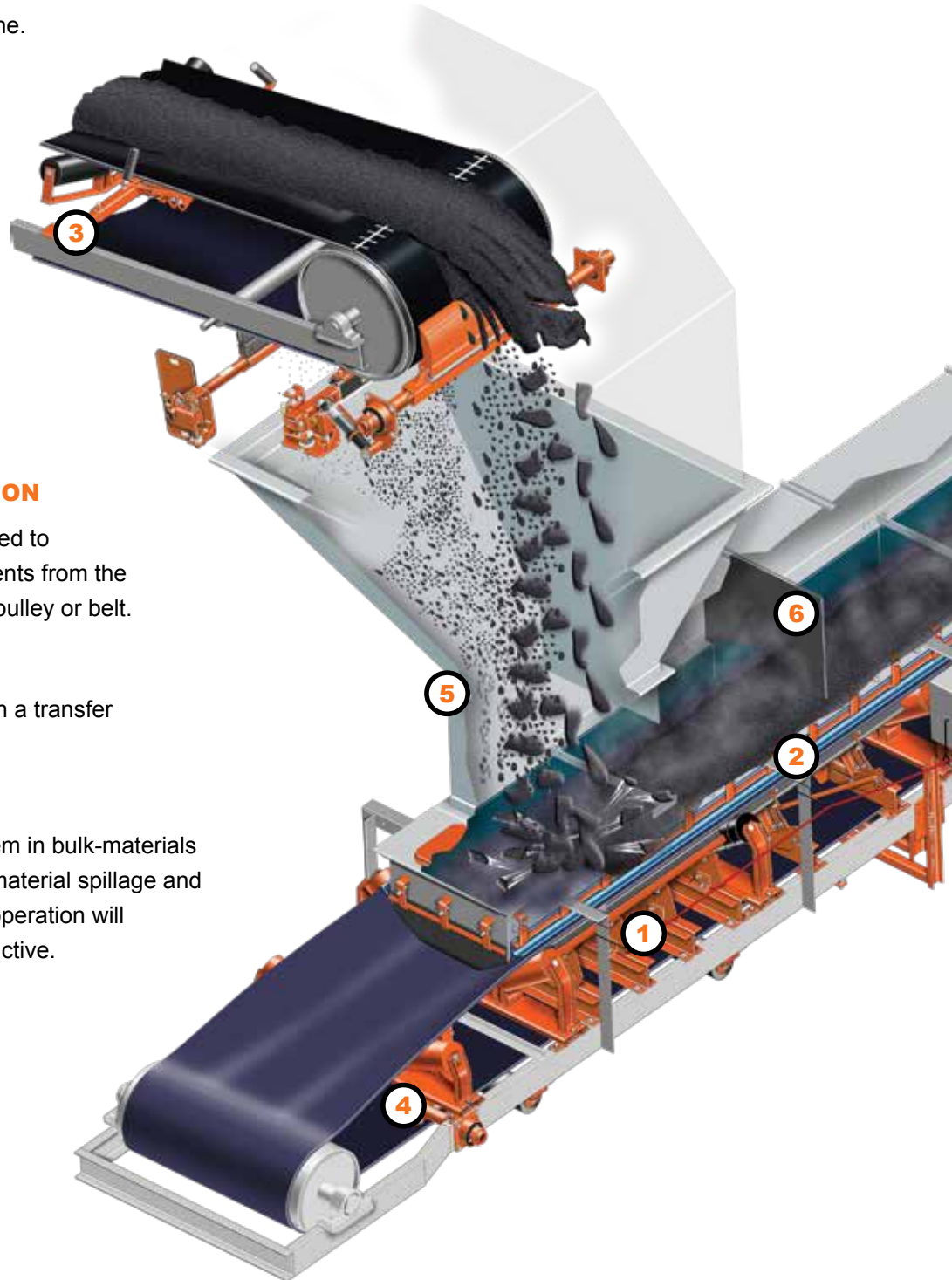



BELT SUPPORT

MARTIN® COMBINATION CRADLE

Installed under a belt conveyor loading zone, the Martin® Combination Cradles absorb the force of falling material to prevent damage to the belt and structure. These medium-duty impact cradles stabilize the belt line to prevent material escape.

The center-roll option reduces friction and requires less conveyor drive horsepower than bars. Roller kit available for use with multiple units.

MODULAR UPGRADE:

Track-mounted to simplify installation and maintenance.

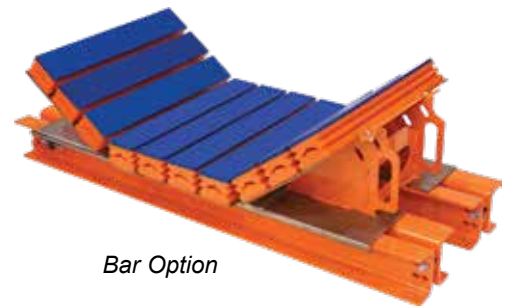

Bar Option



Roller kits available for installing two units back to back



Roller Option



MARTIN® IMPACT CRADLE

Installed under a belt conveyor loading zone, the Martin® Impact Cradle absorbs the force of falling material to prevent damage to the belt and structure. Wing supports adjust to match any standard trough angle. An additional five degrees of fine tuning adjustment enables the cradle to match the idler profiles of different idler manufacturers. Rugged bars are composed of a top layer of low friction UHMW and a lower layer of energy-absorbing polyurethane.



Light Duty

System Selection Guide:

Determine weight of largest lump and drop height.

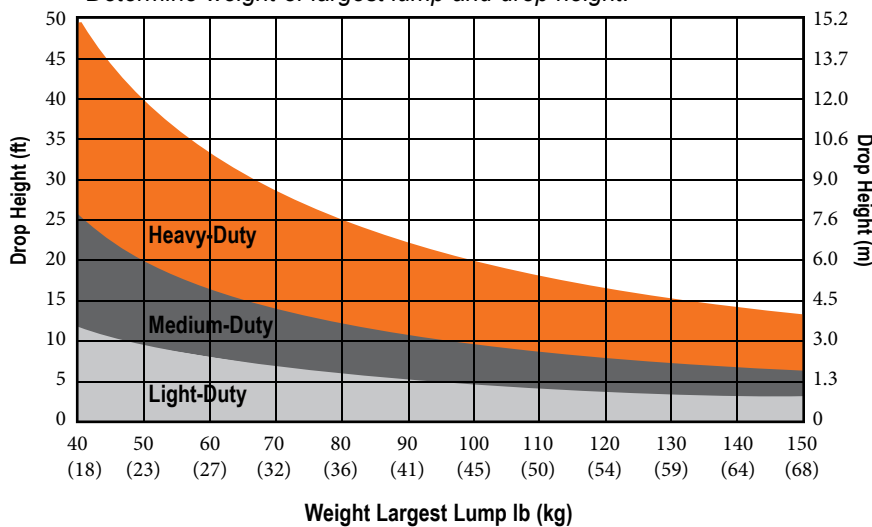

Medium Duty



Heavy Duty

CEMA STANDARD 575-2000

Code Rating		L	M	H
		Light-Duty	Medium-Duty	Heavy-Duty
Impact Force	(lbf.)	< 8,500	< 12,000	< 17,000
	(kN)	< 35	< 53	< 76
W x H (ref.)	lb.-ft.	< 200	< 1000	< 2000
	kg-m	< 28	< 138	< 277

MARTIN® HIGH-SPEED IMPACT CRADLE

Designed and engineered for high speed / high tonnage belts, Martin® High Speed Impact Cradles provide belt support in transfer points where belt speeds exceed the operating limits of ordinary impact bar belt support cradles.



MARTIN® MODULAR SLIDER CRADLE

Eliminates pinch points where trapped material can gouge or tear the belt and stabilizes the belt's path to improve sealing and tracking. Low-friction UHMW bars support belt edges to stabilize the belt line, eliminating belt sag and bounce. Proprietary "box" design allows each bar to be turned over to provide a second wear life.

MODULAR UPGRADE:

Track-mounted to simplify installation and maintenance.



MARTIN® SLIDER CRADLE

Installed under the skirtboard of a transfer point, Martin® Slider Cradles support the edges of the belt to eliminate sag. These cradles prevent transfer point spillage by stabilizing the belt's path and allow the effective sealing of the belt edge. Cradles are available with high-performance UHMW or Stainless Steel Bars to match application requirements.

Center rollers are recommended for applications where capacity is over 450 tph (408 MT/h). Order Support Roller Kit P/N 36725.



MARTIN® IDLER CONVERSION KIT

Simple retrofit links two or more troughing idler frames, replacing the wing rollers with Martin® Slider Bars. Utilizes existing idler frames and center rollers and conforms with idlers from a wide range of manufacturers.



MARTIN® RETURN ROLLER

Sliding track-mount design reduces risk of injury and allows replacement to be done quickly and easily from a single side of the belt. Three-piece hanger frame accommodates belt widths from 24 to 72 inches (500 to 2000 mm). Universal bracket fits most idlers and belt widths.



MARTIN® TRAC-MOUNT™ IDLERS

Idlers slide in and out of position without the need to raise the belt or move adjacent idlers to allow simple service. Clamp mounted to allow precision installation requiring only 8 inches (203 mm) of spacing. Mild steel or rubber rollers for CEMA Class B, C, D, or E.

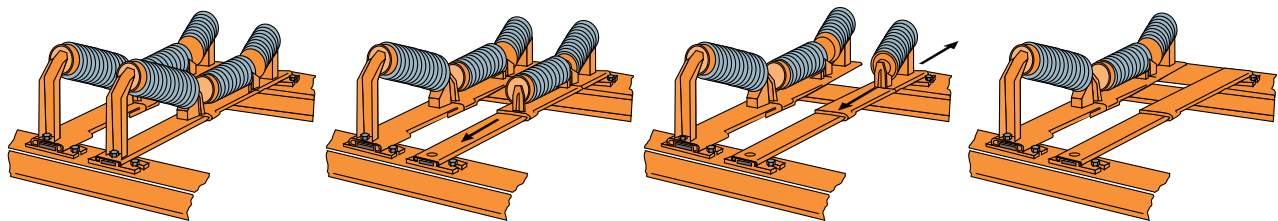
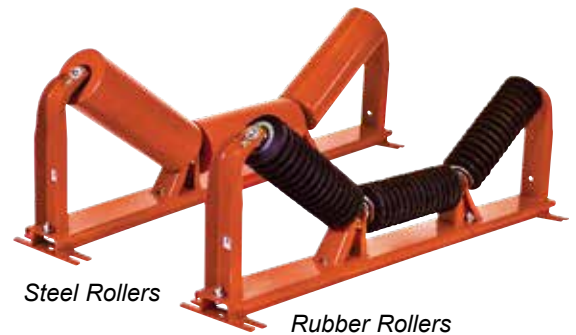

Idler Removal: Simply remove one bolt and sliding roller frames will allow servicing without raising the belt or removing adjacent idlers.



SEALING SYSTEMS

MARTIN® EXTERNAL WEAR LINER

External wear liner is installed on the outside of the chute wall, simplifying wear liner inspection and replacement—both without confined-space entry. Improves liner and skirtboard sealing system performance without adding additional conveyor construction cost. The chute wall can be trimmed to avoid material buildup.



MARTIN® EXTERNAL WEAR LINER RETROFIT

Installed outside conveyor transfer point skirtboards, Martin® External Wear Liner Retrofit Kit is an economical upgrade that improves skirtboard sealing and prevents spillage. It can be used on new installations or to upgrade systems utilizing Martin® ApronSeal™. Wearliners can typically be installed without requiring work inside the chute or interfering with existing chute supports.

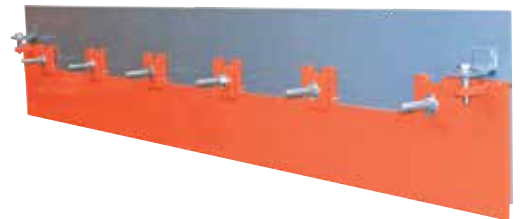

MARTIN® WEAR LINER

Installed inside conveyor transfer point skirtboards, Martin® Wear Liner creates a dam to shield the sealing system from the weight of the material load, prolonging the life of the seal.

Straight wear liner is recommended in transfer points where impact or “bounce” of the material can lead to the entrapment of lumps between deflector liners and the chute wall.

For ease of installation, Martin® Wear Liner is available with pre-drilled and countersunk mounting holes.



MARTIN® APRONSEAL™ SKIRTING

Provides dual-seal efficiency with a single, one-piece sealing strip for any troughing angle to prevent the escape of fines and dust.

ApronSeal™ Double Skirting uses a patented design that features a reversible elastomer strip to provide a second wear life.

Optional quick-release clamps are available.

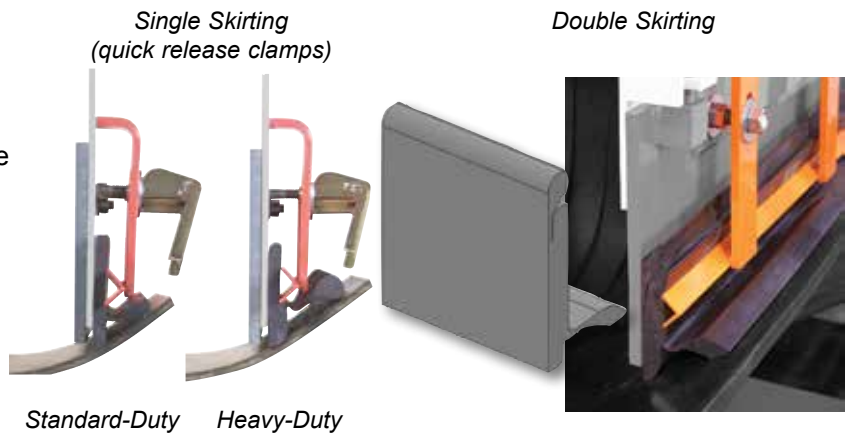

MARTIN® SELF ADJUSTING SKIRTING

Self-adjusting skirting system rides the belt to create an effective seal automatically. Requires only six inches (152 mm) of clearance and only 1.5 inches (38 mm) free belt area for sealing. “L” System has an inward extension under the skirtboard to increase the range of tolerance for belt mistracking. Also available in Urethane XHD profile.



Sealing Systems Application Selection Guide

		Belt Trough Angle													
		0				20				35				45	
Free Belt Area in. (mm)	4.00 (102)	Self-Adjusting Skirting				Standard ApronSeal™				Heavy Duty ApronSeal™					
	3.75 (95)	Self-Adjusting Skirting				Standard ApronSeal™				Heavy Duty ApronSeal™					
	3.50 (89)	Self-Adjusting Skirting				Standard ApronSeal™				Heavy Duty ApronSeal™					
	3.25 (83)	Self-Adjusting Skirting				Standard ApronSeal™				Heavy Duty ApronSeal™					
	3.00 (76)	Self-Adjusting Skirting				Standard ApronSeal™				Heavy Duty ApronSeal™					
	2.50 (63)	Self-Adjusting Skirting				Standard ApronSeal™				Heavy Duty ApronSeal™					
	2.00 (51)	Self-Adjusting Skirting				Standard ApronSeal™				Heavy Duty ApronSeal™					
			0	20	35	45	0	20	35	45	0	20	35	45	
Self-Adjusting Skirting		Standard ApronSeal™				Heavy Duty ApronSeal™									

MARTIN® TAIL SEALING BOX

Forms an effective seal at entry point of transfer point loading zone to prevent material rollback off the conveyor. Keeps material on the belt and off the floor, protecting critical moving parts and components. Back seal clamps are mounted on the outside for ease of service, but the sealing strip lies on the inside for effective sealing.

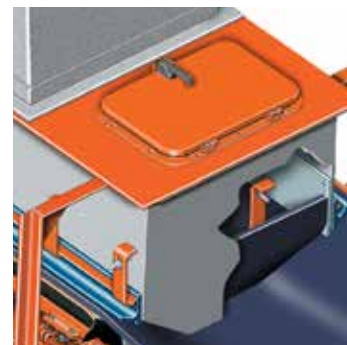



BELT TRACKING

MARTIN® TRACKER™

Provides immediate, powerful, and continuous steering to correct a belt's path, preventing spillage, equipment damage, and repairs. Systems for offset idlers are available. Three duty ratings available to meet material handling needs.



upper unit



lower unit

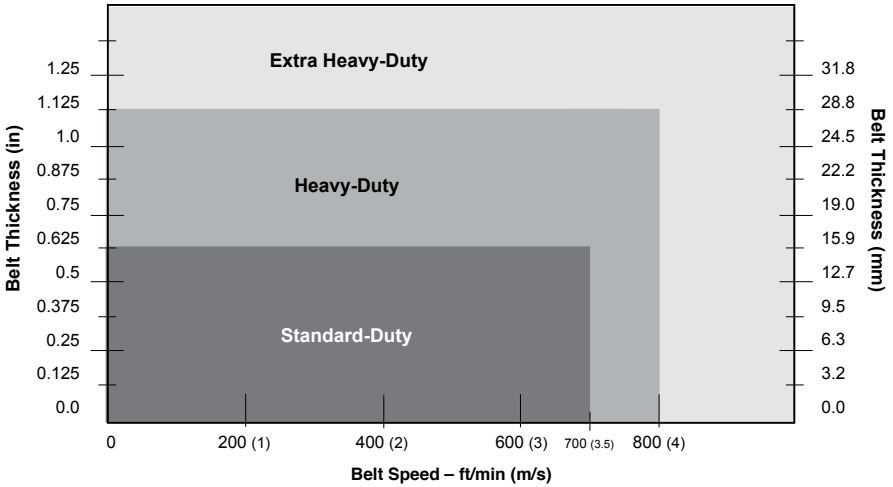

HOW IT WORKS:

The Martin® Tracker has four main sections: steering roll, torque arm, parallel stay, and guide rolls. As the belt contacts the guide rolls, the torque arm pivots the steering roll, causing the belt to track to the center of the conveyor structure.

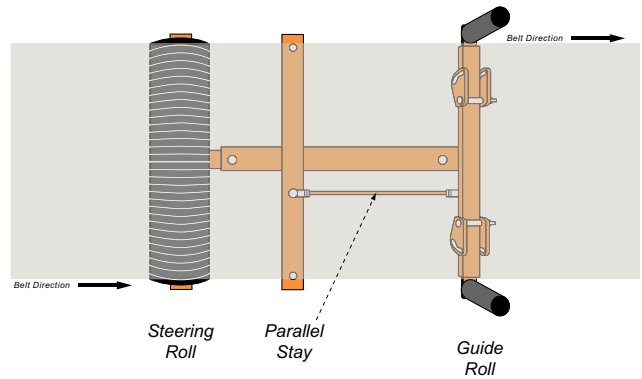
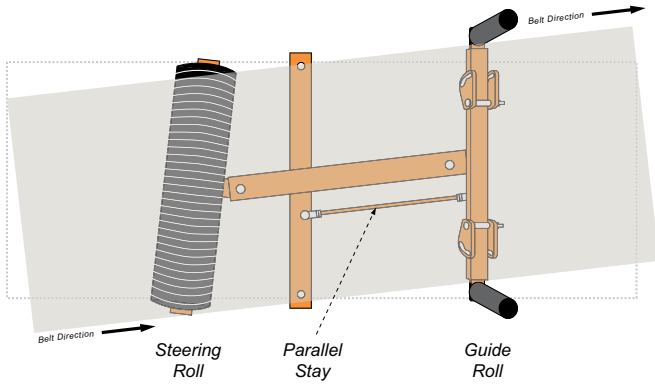

MARTIN® REVERSING TRACKER™

Reversing Tracker™ features sensing rollers and lever arms on both sides of the unit. Available with stainless steel paddle wheel or air cylinder to activate the sensing rolls on the proper end of the unit.



MARTIN® IDLER ALIGNER

Provides a safe and effective method to manually fine tune self-adjusting idlers. Eliminates the need to tie off idlers to surrounding structure and allows workers to safely and conveniently make manual adjustments from outside of the stringer. Features a hole for padlock placement to restrict access. Installation is a one-person job, requiring no measuring, cutting, or heavy lifting.





TAIL PULLEY PROTECTION

MARTIN® VPLOW XHD

Rugged, modular design with urethane side blades for longer wear and lower friction. Designed for 42 to 96 in. (1,000 to 2,400 mm) belt widths. Three-piece frame construction simply bolts together for ease of assembly. Includes reversible mounts so the frame can be cut and installed between the stringers.



MARTIN® VPLOW HD

Economical solution for tail pulley protection in light- to moderate-duty applications. Effectively removes material before the conveyor enters the tail pulley, with a simple yet secure mounting that protects both the plow and pulley.



MARTIN® TORSION VPLOW PLUS

The Martin® Torsion VPlow Plus is mounted with a unique suspension that allows the plow to rise and fall with fluctuations in belt tension and travel. This makes it self-adjusting for effective cleaning in all stages of blade wear. Can be used on belt speeds up to 900 fpm (4.6 m/sec).

Easily replaceable blade provides 2 in. (50 mm) of wear life. Blade is available in 60 Shore A Durometer Nitrile rubber or long-wearing 90 Shore A Durometer urethane.



MARTIN® DIAGONAL PLOW

Prevents stray material from damaging the tail pulley, lagging, or belting on reversing belts. Hung from brackets on both sides of the conveyor, the Diagonal Plow is engineered to float on the belt surface with pressure for cleaning, but without adding to belt tension or conveyor-drive power requirements.





CHUTE STRUCTURE

MARTIN® MODULAR CHUTE WALL

Pre-engineered, pre-fabricated components make it easy to design and install transfer point skirtboards and stilling zones to manage air flow and control dust. Compatible with Martin® External Wear Liner and Martin® Belt Sealing.



MARTIN® MODULAR SKIRTBOARD COVER & CHUTE WALL

Keeps climatic conditions outside and airborne dust inside. Installs simply and reduces cleanup expenses and environmental problems by 'shedding' debris and material to a safe area away from moving parts. Easy removal allows for inspection of material and belt movement.



TYPICAL SYSTEM COMPONENTS STILLING ZONE TRANSFER

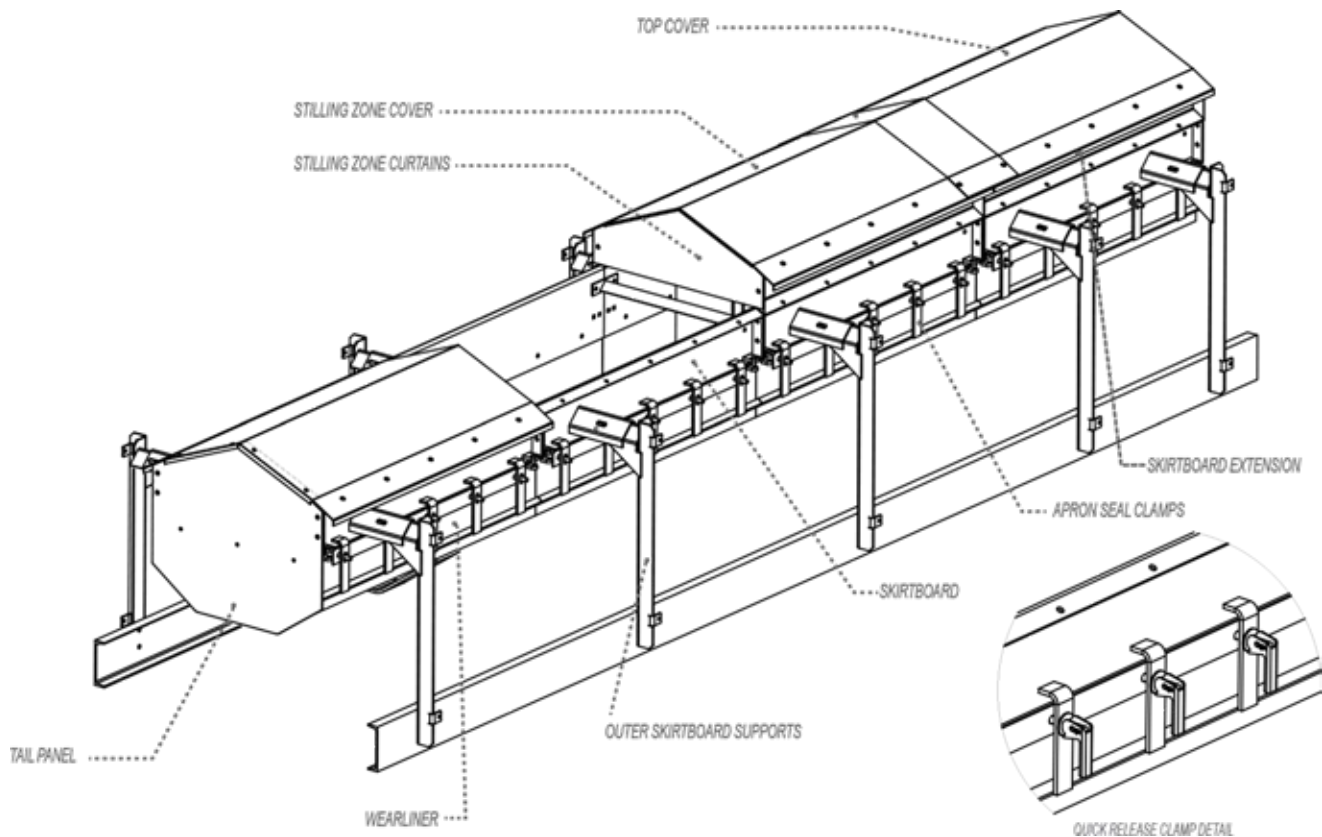

Contact your Martin Engineering representative to discuss the best solution to meet your specific needs.

BELT SUPPORT

Martin® Combination Cradle

Cradle/Bars P/N	UCGBB
Cradle/Roller P/N	UCGBR
Flat Cradle P/N	31880
Picking Cradle P/N	37057
Roller Cradle Roller Kit P/N	UC-001670
Bar Material	Rubber/Urethane
Replacement Bar (Urethane/UHMW)	UC-001630
Duty Rating	Medium

Martin® Impact Cradle HD

P/N	37357
Replacement Bar (Rubber/UHMW)	36570
Standard Bar Length	24 in
Top Cover Material	UHMW

Martin® Impact Cradle LD & MD

Medium Duty - 4ft bars P/N	36318
Medium Duty - 5ft bars P/N	36516
Light Duty P/N	36010
Replacement Bar (Urethane/UHMW)	39102-4
Standard Bar Length	48 in.
Top Cover Material	UHMW

Martin® Trac-Mount Idlers

P/N	TMIXXP
Roller Options	Steel, Impact, Combination
Diameter Range	4 to 7 inches
CEMA Classes	A through E

Martin® Return Roller

P/N	UCRR
-----	------

Martin® Modular Slider Cradle

P/N	UCGS
Bar Material	UHMW Polyethylene

Martin® Slider Cradle

P/N	36700
Replacement bars P/N	31275
Standard Bar Length	48 in.
Bar Material	UHMW Polyethylene

Martin® Idler Conversion Kit

P/N	37135
Bar Material	UHMW Polyethylene

Martin® High-Speed Roller Cradle

P/N	HSRC
-----	------

BELT SEALING

Martin® External Wear Liner

P/N	UC-003010
-----	-----------

Martin® ApronSeal™ Skirting

Sealing System Selection Guide	L3636
Single Skirting P/N	100724
Single Skirting HD P/N	100723
Double Skirting P/N	100873
Double Skirting HD P/N	100861
Material Durometer	60 or 70 (standard)
Continuous lengths	300 feet
Trough Range	0° to 45°
Clamp Options	standard, low-profile, heavy-duty, quick release

Martin® Self Adjusting Skirting HD

P/N	37911
Replacement Rubber P/N	37911-R
Continuous Lengths	100 feet
Min. belt edge requirement	1.25 inches

Martin® Tail Sealing Box

P/N	33268
-----	-------



BELT ALIGNMENT

Martin® Tracker™

Standard Duty P/N	TKR-(24-54)XS
Heavy Duty P/N	TKR-(36-72)XH
Extra Heavy Duty P/N	TKR-(60-96)XM

Martin® Tracker™ Reversing

Upper P/N	34695
Lower P/N	34694

Martin® Idler Aligner

P/N	38654
-----	-------

TAIL PULLEY PROTECTION

Martin® VPlow XHD

P/N	PLWVH
Max. Belt Speed	1000 fpm
Blade Material	Urethane

Martin® VPlow HD

P/N	31106
Replacement Blade P/N	31134
Max. Belt Speed:	900 fpm
Blade Material:	Rubber or Urethane

Martin® Torsion VPlow Plus

P/N	CPVTAS
Rubber Blade P/N	CPVTBSXXR
Urethane Blade P/N	CPVTBXXXX
Max. Belt Speed:	900 fpm
Blade Material:	Rubber or Urethane

Martin® Diagonal Plow

P/N	22662
Rubber Blade P/N	24112
Urethane Blade P/N	25403
Max. Belt Speed:	900 fpm
Blade Material:	Rubber or Urethane

CHUTE STRUCTURE

Martin® Modular Chute Wall

P/N	UC-003000
-----	-----------

Martin® Modular Skirtboard Cover

P/N	UC-00307
-----	----------

All components included for complete transfer point. Contact Martin for more details.

SAFETY FIRST

Martin® Conveyor Guards

P/N	UCBG
-----	------

Martin® Conveyor Guards

P/N	UCBG
Steel door P/N	CYA
Round steel door P/N	CYARD
Extended-height steel door P/N	CYAE



GLOBAL LOCATIONS

 UNITED STATES

 AUSTRALIA

 BRAZIL

 CHINA

 FRANCE

 GERMANY

 INDIA

 INDONESIA

 ITALY

 MEXICO

 PERU

 RUSSIA

 SPAIN

 SOUTH AFRICA

 TURKEY

 UNITED KINGDOM

Authorized representatives in over 32 additional countries

MARTIN ENGINEERING USA

One Martin Place

Neponset, IL 61345-9766 USA

800-544-2947 or 309-852-2384

info@martin-eng.com

www.martin-eng.com

Part No. L3649-2/21