

EVOGEAR SERIES

EvoGear is the next generation of hypoid gearing performance. It confidently combines the efficiency and compactness of a hypoid primary stage with the torque density and low backlash of the VRS and VRT planetary products. Tapered roller bearings on the input and output side of the gearbox absorb high radial and axial loads, ensuring long service life. A planetary output is used to achieve very high ratios.

EvoGear comes in four different output configurations and 17 reduction ratios to allow for use in a vast array of applications. Ratios up to 15:1 are available in a single stage, making it a compact design for small installation envelopes. Lubricated for life, EvoGear is a reliable maintenance-free solution.

	Relative Cost	Load Capacity	Duty Cycle	Positional Accuracy
Optimal	Light	Light	Light	Light
Exceptional	Light	Light	Light	Light
Suitable	Light	Light	Light	Light

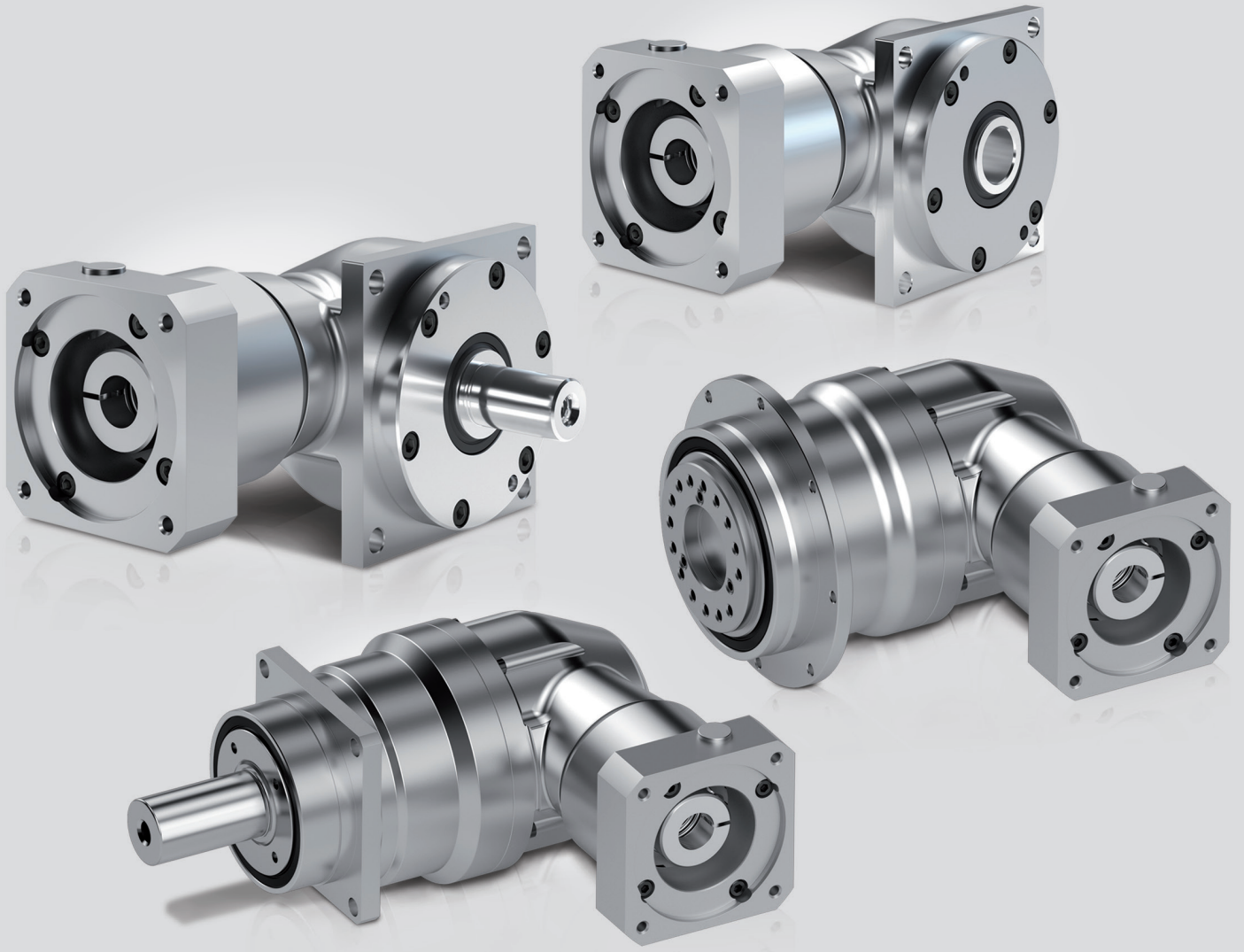

EVOGEAR SERIES

- New generation of right-angle products that combine the efficiency and compactness of a hypoid primary stage with the torque density and low backlash of the VRS and VRT planetary outputs
- Low backlash (down to <math><4\text{ arc-min}</math>), high torsional stiffness, smooth torque transmission and negligible noise. Efficiency as high as 96%
- 4 Frame sizes, 17 reduction ratios and 4 output mounting configurations
- Compact, rigid, weight efficient design
- Maintenance-free solution that is lubricated for life
- Assembled in Germany

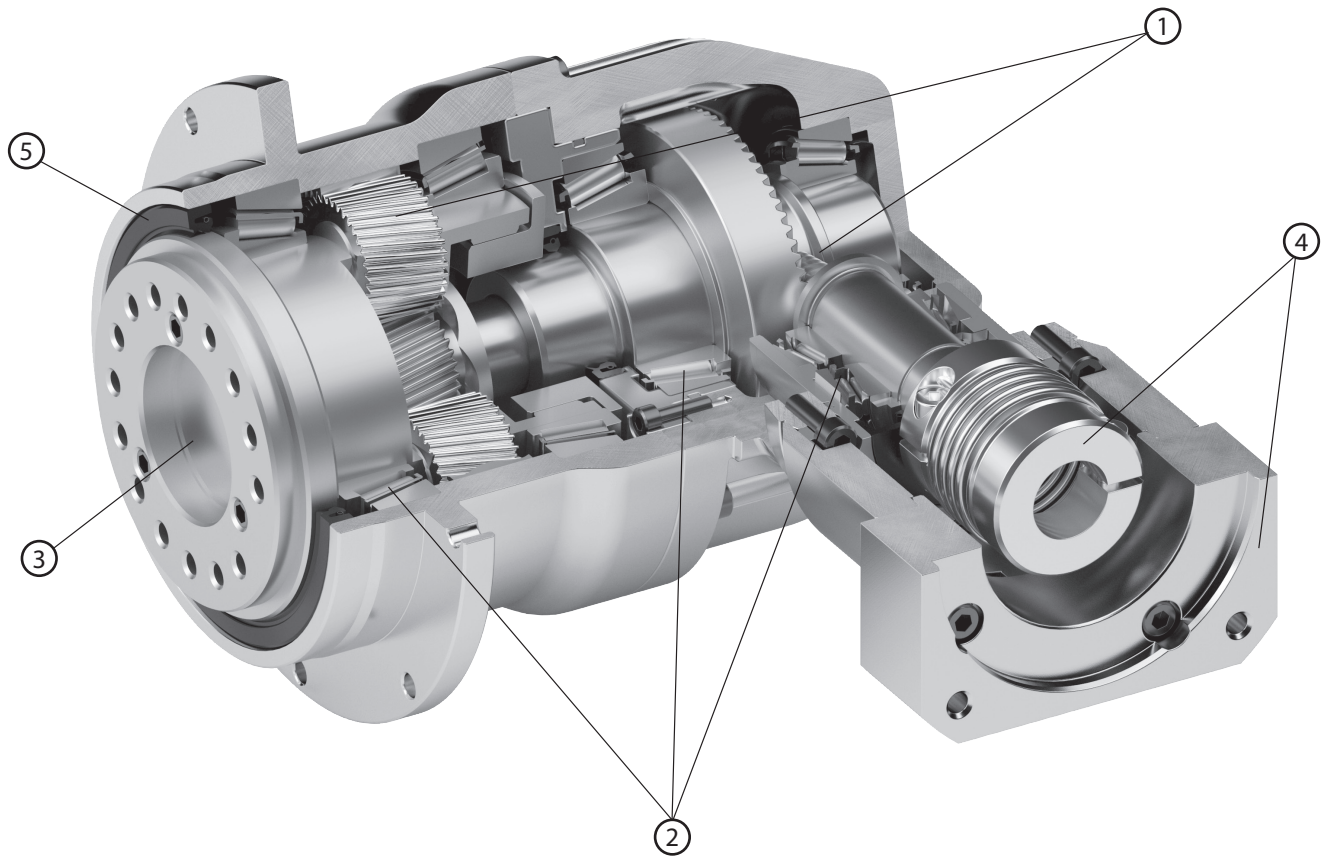

- ① Hypoid input stage with optional planetary output stage. Planetary section includes carburized case-hardened helical gears with proprietary secondary finishing process for higher accuracy and smooth, quiet operation
- ② Tapered roller bearings at input and output stages for high radial, axial and tilting moment load capacity
- ③ Three output mounting styles for maximum flexibility: Solid shaft, hollow shaft, ISO 9409-1 robot flange. Industry standard dimensional compatibility
- ④ Simple, concentric, low inertia connection to various servo motors using adapter flange and stiff zero backlash coupling. Ready for dynamic or high-speed applications
- ⑤ Output seal allows for IP64 protection

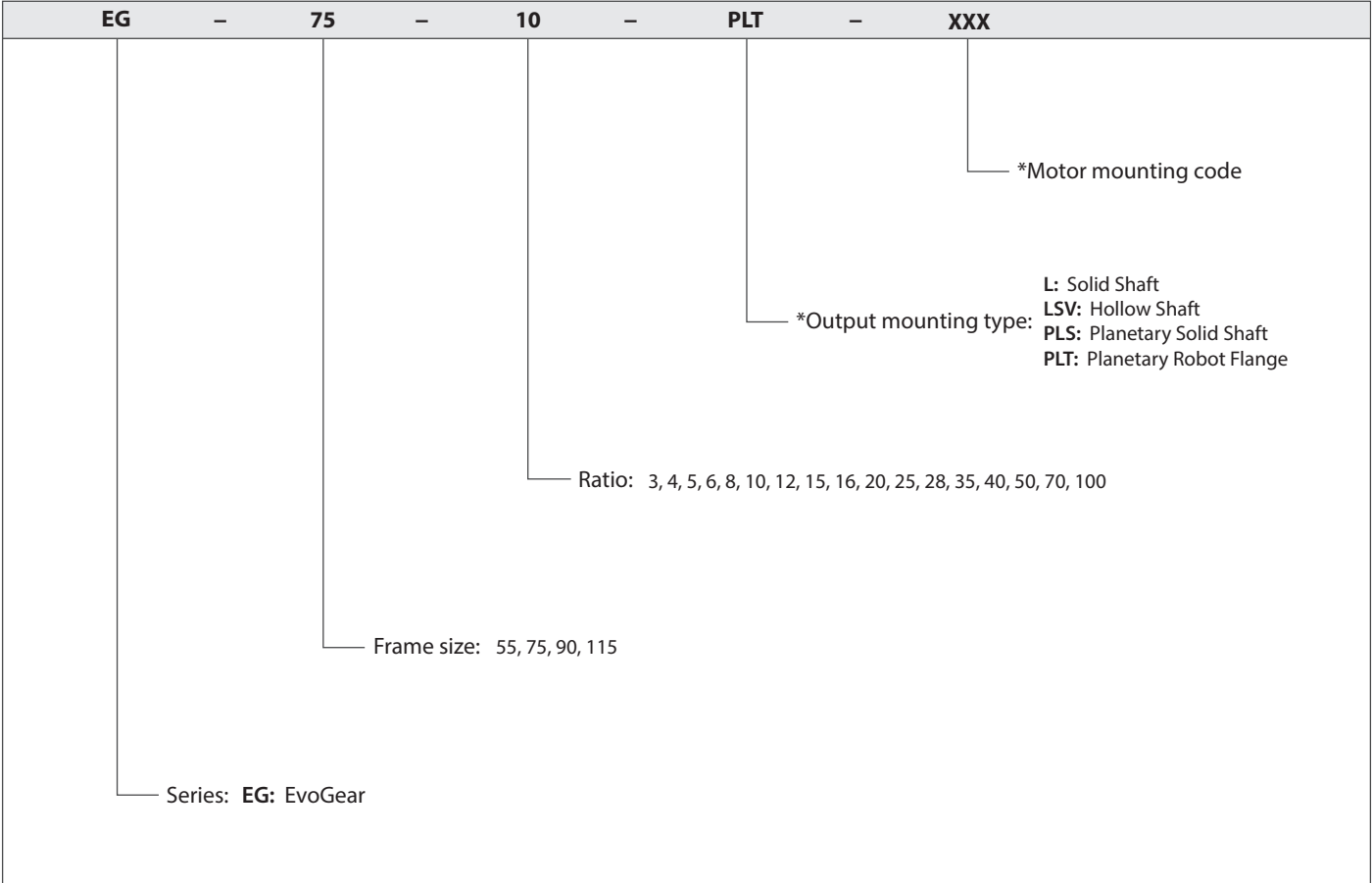

* Motor mounting code varies depending on the motor. Contact us to configure the code.

Solid and Hollow Shaft - L, LSV Configurations

Frame Size	Units	Note	55	75	90	115	55	75	90	115
Ratio	i		3/4/5/6/8/10				12/15			
Nominal Output Torque	T2N [Nm]	*1	35	70	140	260	25	50	95	180
Maximum Acceleration Torque	T2B [Nm]	*2	53	105	210	390	38	75	143	270
Emergency Stop Torque	T2Not [Nm]	*3	70	140	280	520	50	100	190	360
Nominal Input Speed	n1N [rpm]	*4	3100	2400	2100	1820	3800	2900	2600	2250
Maximum Input Speed	n1max [rpm]	*5	6000	6000	5000	4000	6000	6000	5000	4000
Maximum Radial Load	F2Rmax [N]	*6	3300	4900	7200	10000	3300	4900	7200	10000
Maximum Axial Load	F2Amax [N]	*7	2650	2450	3600	5000	1650	2450	3600	5000
Moment of Inertia (Ratio 3)	[kgcm ²]		0.376	0.958	2.35	6.82	-	-	-	-
Moment of Inertia (Ratio 4)	[kgcm ²]		0.275	0.715	1.73	4.92	-	-	-	-
Moment of Inertia (Ratio 5)	[kgcm ²]		0.224	0.577	1.41	3.84	-	-	-	-
Moment of Inertia (Ratio 6)	[kgcm ²]		0.217	0.529	1.42	3.62	-	-	-	-
Moment of Inertia (Ratio 8)	[kgcm ²]		0.177	0.440	1.13	2.84	-	-	-	-
Moment of Inertia (Ratio 10)	[kgcm ²]		0.157	0.396	0.99	2.47	-	-	-	-
Moment of Inertia (Ratio 12)	[kgcm ²]		-	-	-	-	0.146	0.366	0.91	2.27
Moment of Inertia (Ratio 15)	[kgcm ²]		-	-	-	-	0.135	0.345	0.85	2.10
Efficiency	h [%]	*8	> 96	> 96	> 96	> 96	> 93	> 93	> 93	> 93
Torsional Rigidity	Ct21 [Nm/arcmin]	*9	2.1	4.2	10.5	23.4	2.1	4.2	10.5	23.4
Maximum Torsional Backlash	jt [arcmin]	*10	≤ 6	≤ 5	≤ 5	≤ 4	≤ 4	≤ 4	≤ 4	≤ 4
Noise Level	LpA [dB(A)]	*11	< 66	< 66	< 68	< 68	< 66	< 66	< 68	< 68
Ambient Temperature	[°C]	-	-10 to 90							
Permitted Housing Temperature	[°C]	-	90							
Protection Class	-	-	IP64							
Lubrication	-	-	Synthetic Oil [ISO VG-Class 150]							
Service Life	SL [h]	*12	30,000							
Weight	m [kg]	-	2.9	4.8	8.6	13.3	2.9	4.8	8.6	13.3

*1) At nominal input speed, service life is 30,000 hours

*2) The maximum torque when starting or stopping operation. Permitted 1,000 cycles/hour

*3) The maximum torque allowed under a stress situation. Permitted 1,000 times during service life

*4) The average input speed at nominal input torque. Maintain housing temperature below permitted value

*5) The maximum intermittent input speed

*6) The maximum radial load the gearbox can accept. Measured at center of output shaft at 400rpm output

*7) The maximum axial load the gearbox can accept. Measured at center of output shaft at 400rpm output

*8) The efficiency at full load

*9) At nominal output torque. Does not include lost motion

*10) Measured at output, 2% load and max 10Nm

*11) Measured at 3,000 rpm input

*12) Based on S5 duty cycle <60% and <20 minute run time

Units and Symbols

Maximum Motor Acceleration Torque	T1BMot	Nm
Nominal Output Torque	T2N	Nm
Maximum Acceleration Torque	T2B	Nm
Emergency Stop Torque	T2Not	Nm
Nominal Input Speed	n1N	rpm
Maximum Input Speed	n1max	rpm
Maximum Input Radial Load	F1Rmax	N
Maximum Output Radial Load	F2Rmax	N
Maximum Input Axial Load	F1Amax	N
Maximum Output Axial Load	F2Amax	N
Mass Moment of Inertia	I1	kgcm ²
Efficiency at Full Load	η	%
Torsional Rigidity	Ct21	Nm/arc-min
Maximum Torsional Backlash	jt	arc-min
Noise Level	LpA	dB(A)
Service Life	Lh	h
Run time	RT	min
Duty cycle	DC	%
Ambient Temperature	ta	°C
Thermal Performance Limit	Ptherm	kW
Performance	P	kW
Weight	m	kg

Planetary Solid Shaft and Robot Flange - PLS, PLT Configurations

Frame Size	Units	Note	Ratio	55	75	90	115
Nominal Output Torque	T2N [Nm]	*1	16	80	200	380	850
Maximum Acceleration Torque	T2B [Nm]	*2		165	390	840	1850
Emergency Stop Torque	T2Not [Nm]	*3		250	625	1250	2750
Nominal Output Torque	T2N [Nm]	*1	20	86	220	410	910
Maximum Acceleration Torque	T2B [Nm]	*2		165	390	840	1850
Emergency Stop Torque	T2Not [Nm]	*3		250	625	1250	2750
Nominal Output Torque	T2N [Nm]	*1	25	106	280	590	1100
Maximum Acceleration Torque	T2B [Nm]	*2		165	390	840	1850
Emergency Stop Torque	T2Not [Nm]	*3		250	625	1250	2750
Nominal Output Torque	T2N [Nm]	*1	28/35/40/50/70	118	280	590	1300
Maximum Acceleration Torque	T2B [Nm]	*2		165	390	840	1850
Emergency Stop Torque	T2Not [Nm]	*3		250	625	1250	2750
Nominal Output Torque	T2N [Nm]	*1	100	88	220	440	930
Maximum Acceleration Torque	T2B [Nm]	*2		112	292	610	1350
Emergency Stop Torque	T2Not [Nm]	*3		200	500	1000	2200
Nominal Input Speed	n1N [rpm]	*4	16-100	2700	2700	2600	2100
Maximum Input Speed	n1max [rpm]	*5	16-100	8000	8000	7000	6000
Maximum Radial Load (PLS)	F2Rmax [N]	*6	16-100	4300	7000	10000	19000
Maximum Axial Load (PLS)	F2Amax [N]	*7	16-100	3900	6300	9000	17000
Maximum Radial Load (PLT)	F2Rmax [N]	*6	16-100	3300	12000	19000	40000
Maximum Axial Load (PLT)	F2Amax [N]	*7	16-100	1700	8800	14000	30000
Moment of Inertia (PLS)	[kgcm ²]	-	16	0.302	0.829	2.20	6.43
	[kgcm ²]	-	20	0.241	0.649	1.71	4.81
	[kgcm ²]	-	25	0.238	0.629	1.65	4.57
	[kgcm ²]	-	28	0.292	0.772	2.00	5.74
	[kgcm ²]	-	35	0.235	0.613	1.58	4.37
	[kgcm ²]	-	40	0.182	0.462	1.20	3.11
	[kgcm ²]	-	50	0.160	0.410	1.03	2.64
	[kgcm ²]	-	70	0.160	0.406	1.02	2.59
	[kgcm ²]	-	100	0.159	0.404	1.01	2.57
Moment of Inertia (PLT)	[kgcm ²]	-	16	0.321	0.904	2.44	8.19
	[kgcm ²]	-	20	0.253	0.698	1.86	5.93
	[kgcm ²]	-	25	0.246	0.666	1.76	5.33
	[kgcm ²]	-	28	0.298	0.804	2.09	6.38
	[kgcm ²]	-	35	0.239	0.634	1.64	4.77
	[kgcm ²]	-	40	0.185	0.476	1.24	3.41
	[kgcm ²]	-	50	0.162	0.419	1.06	2.84
	[kgcm ²]	-	70	0.161	0.411	1.03	2.70
	[kgcm ²]	-	100	0.160	0.407	1.02	2.63
Efficiency	h [%]	*8	16-100	> 94	> 94	> 94	> 94
Torsional Rigidity (PLS)	Ct21 [Nm/arcmin]	*9	16-100	10	31	60	175
Torsional Rigidity (PLT)	Ct21 [Nm/arcmin]	*9	16-100	27	64	143	430
Maximum Torsional Backlash (Standard)	jt [arcmin]	*10	16-100	≤ 5	≤ 4	≤ 4	≤ 4
Noise Level	LpA [dB(A)]	*11	16-100	< 68	< 68	< 70	< 70
Ambient Temperature	[°C]	-	-10 to 90				
Permitted Housing Temperature	[°C]	-	90				
Protection Class	-	-	IP64				
Lubrication	-	-	Synthetic Oil [ISO VG-Class 150]				
Service Life	SL [h]	*12	20,000				
Weight (PLS)	m [kg]	-	16-100	5.0	9.9	19.5	38.0
Weight (PLT)	m [kg]	-	16-100	5.2	9.7	18.0	41.0

*1) At nominal input speed, service life is 30,000 hours

*2) The maximum torque when starting or stopping operation. Permitted 1,000 cycles/hour

*3) The maximum torque allowed under a stress situation. Permitted 1,000 times during service life

*4) The average input speed at nominal input torque. Maintain housing temperature below permitted value

*5) The maximum intermittent input speed

*6) The maximum radial load the gearbox can accept. Measured at center of output shaft at 400rpm output

*7) The maximum axial load the gearbox can accept. Measured at center of output shaft at 400rpm output

*8) The efficiency at full load

*9) At nominal output torque. Does not include lost motion

*10) Measured at output, 2% load and max 10Nm

*11) Measured at 3,000 rpm input

*12) Based on S5 duty cycle <60% and <20 minute run time

Solid Shaft, Hollow Shaft, Planetary Solid Shaft - L, LSV, PLS Configurations

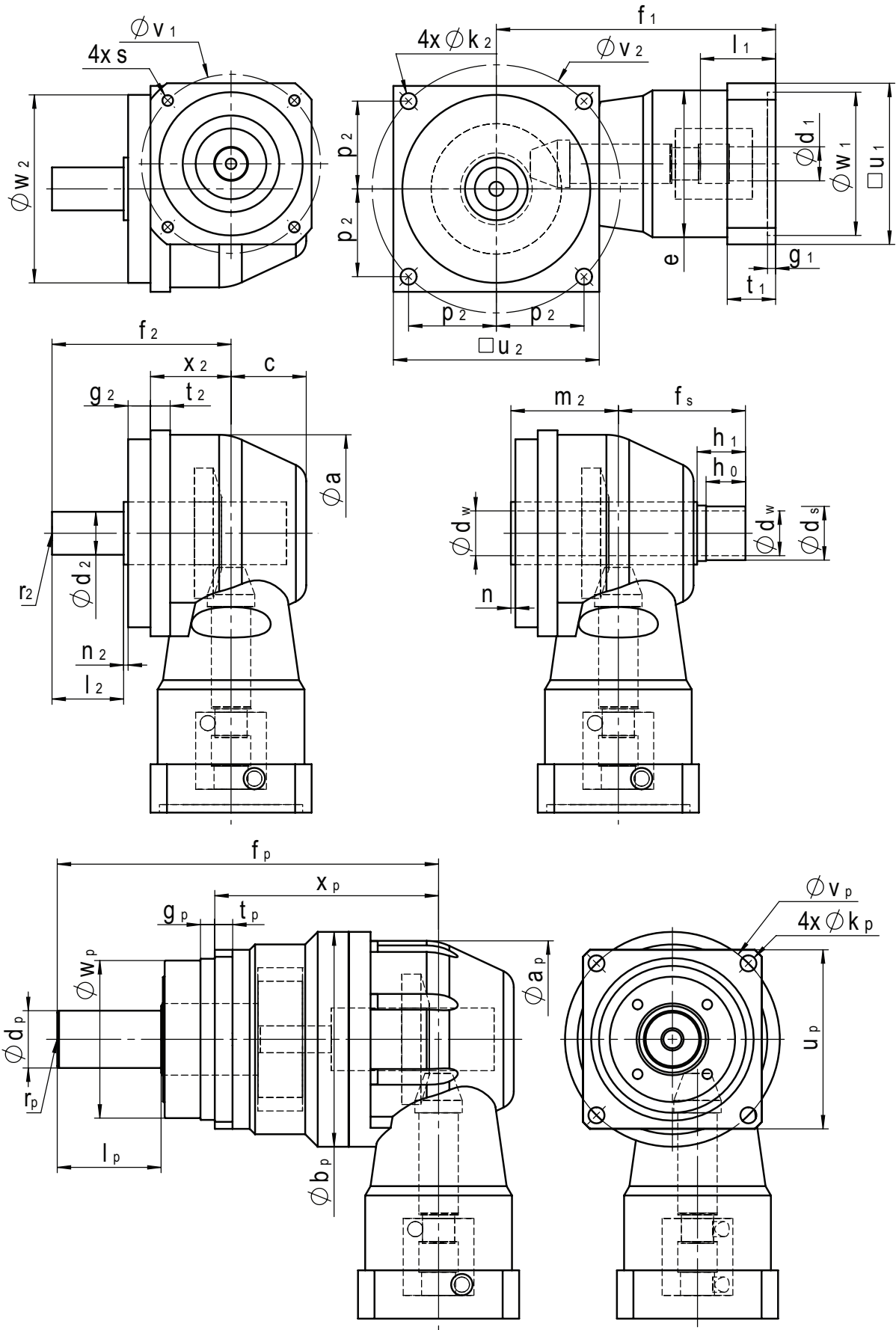

Solid Shaft, Hollow Shaft, Planetary Solid Shaft - L, LSV, PLS Configurations

Input Dimensions

Frame Size	e	f1	g1	t1	Ød1	l1	□u1	Øv1	Øw1F7	s
55	Ø60	133	4.5	20	9	23	60	63	40	M4
					11	26	75	75	60	M5
					14	33	75	75	60	M5
75	Ø82	156	4.5	27	11	26	75	75	60	M5
					14	33	75	75	60	M5
					19	43	90	100	80	M6
90	Ø90	182	4.5	33	14	33	90	100	80	M6
					19	43	90	100	80	M6
					24	53	115	130	110	M8
115	Ø114	209.5	6.0	40	19	43	115	130	110	M8
					24	53	115	130	110	M8
					32	63	140	165	130	M10

Solid Output Dimensions

Frame Size	Øa	c	Ød2k6	l2	f2	n2	r2	x2	g2	t2	Øk2	p2	□u2	Øv2	Øw2 g6
55	87	36	20	35	87	1.5	M6	37	13.5	9	6.6	39	90	110.3	89
75	110	42	24	40	100	2.5	M8	45	12.5	11	9	49	115	138.6	105
90	134	52	32	50	122.5	2	M12	58	12.5	14	11	59	140	166.9	125
115	162	63	40	60	149	3	M16	71	15	17	13.5	75	170	203.6	150

Hollow Output Dimensions

Frame Size	Øa	c	ØdwH7	Ødsf7	h0	h1	fs	m2	n	x2	g2	t2	Øk2	p2	□u2	Øv2	Øw2 g6
55	87	36	20	24	20	26.5	64.5	52	1.5	37	13.5	9	6.6	39	90	110.3	89
75	110	42	25	30	22	27	71	60	2.5	45	12.5	11	9	49	115	138.6	105
90	134	52	30	36	26	33	87	72.5	2	58	12.5	14	11	59	140	166.9	125
115	162	63	40	50	29	37	102	89	3	71	15	17	13.5	75	170	203.6	150

* Includes extended shaft for shrink disc. Shrink disc sold separately

Planetary Solid Output Dimensions

Frame Size	Øap	Øbp	Ødp j6	lp	fp	rp	□up	Øvp	Øwp g6	xp	tp	gp	Økp
55	89	89	22	36	167	M8	75	85	70	111	7	6	6.6
75	115	120	32	58	213	M12	100	120	90	125	10	8	9
90	142	150	40	82	263.5	M16	140	165	130	151.5	12	10	11
115	181	200	55	82	300.5	M20	180	215	160	188.5	15	12	13.5

* Optional keyed output shaft available

Planetary Robot Flange - PLT Configuration

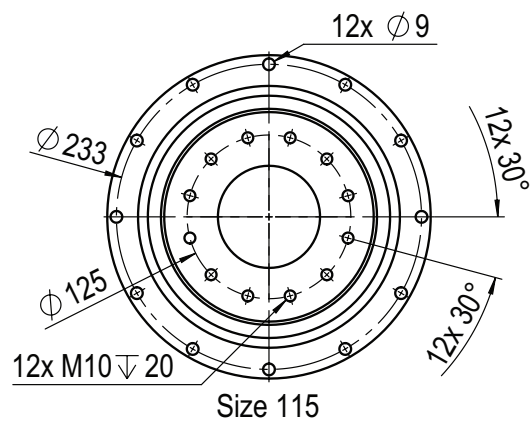
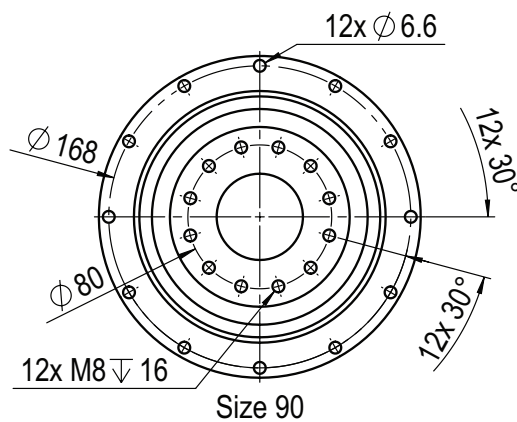
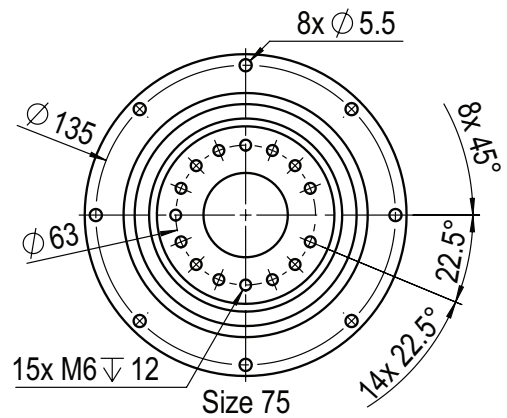
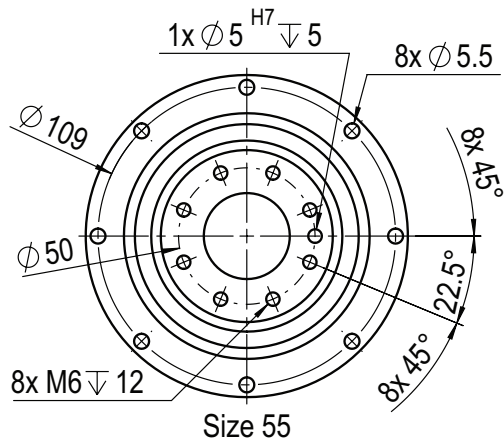
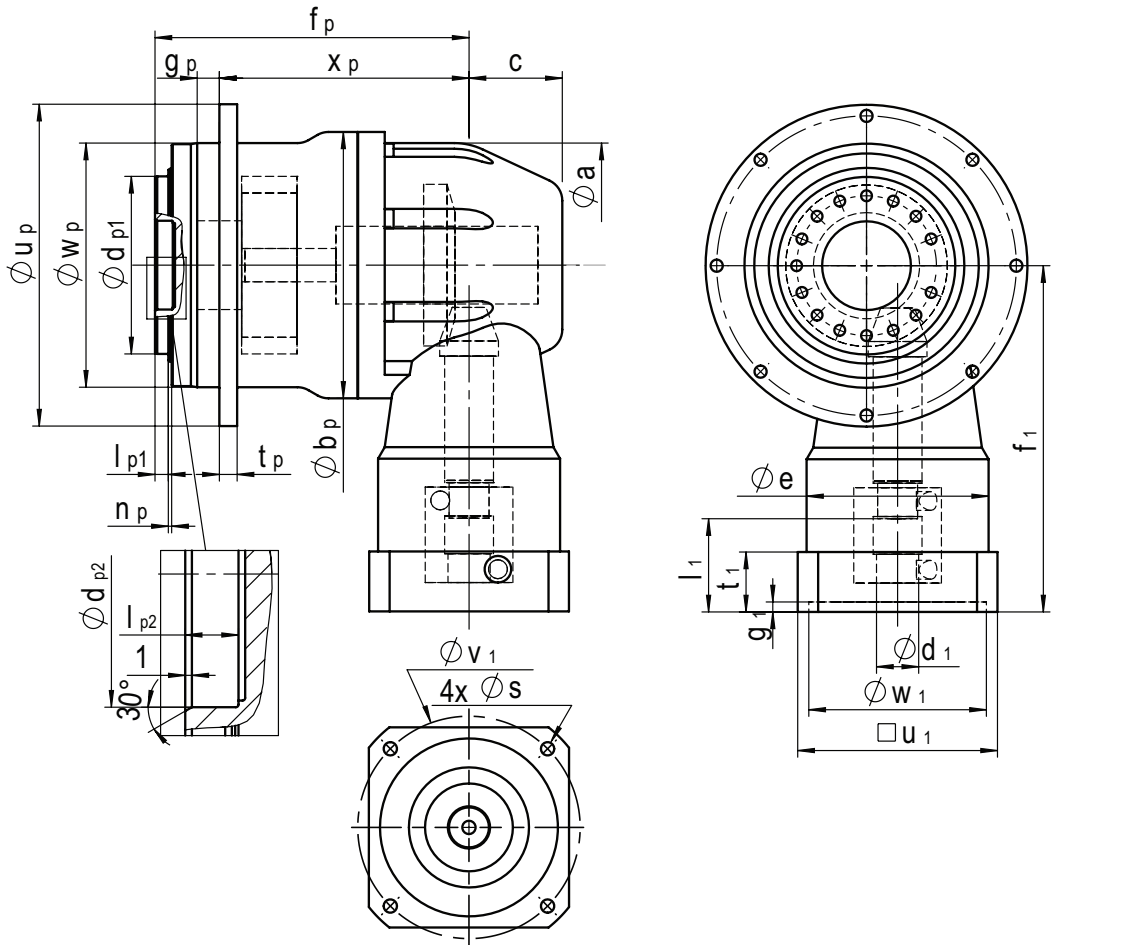

Planetary Robot Flange - PLT Configuration

Input Dimensions

Frame Size	e	f1	g1	t1	Ød1	l1	□u1	Øv1	Øw1F7	s
55	Ø60	133	4.5	20	9	23	60	63	40	M4
					11	26	75	75	60	M5
					14	33	75	75	60	M5
75	Ø82	156	4.5	27	11	26	75	75	60	M5
					14	33	75	75	60	M5
					19	43	90	100	80	M6
90	Ø90	182	4.5	33	14	33	90	100	80	M6
					19	43	90	100	80	M6
					24	53	115	130	110	M8
115	Ø114	209.5	6.0	40	19	43	115	130	110	M8
					24	53	115	130	110	M8
					32	63	140	165	130	M10

Planetary Robot Flange Output Dimensions

Frame Size	Øa	c	xp	fp	Ødp1 h7	lp1	Ødp2F7	lp2	Øup	Øwp h7	tp	gp	Øbp
55	89	36	72.5	102.5	63	6	31.5	6	118	90	7	10	89
75	115	42	112.5	141.5	80	6	40	8	145	110	8	10	120
90	142	52	126	164	100	6	50	10	179	140	10	14	150
115	181	63	159	209	160	8	80	16	247	200	12	15	208

* Above input dimensions are for reference only and depend on motor dimensions
 Contact us to configure the appropriate adaptation for your specific motor.