

PIX

D R I V I N G G R O W T H

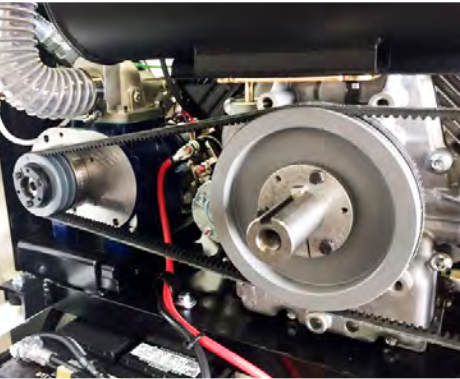

MANUFACTURER OF **POWER TRANSMISSION BELTS** FOR ALL DRIVE TYPES.



Our state-of-the-art manufacturing facilities in Nagpur, India.

PIX NORTH AMERICA

PIX is an international leader in the production of high-quality power transmission belts with state-of-the-art manufacturing facilities in India supported by sales, service and distribution centers in the United States, United Kingdom, Germany and the United Arab Emirates. All PIX products are developed by our extensive team of engineers using cutting-edge production methods that comply with ISO/TS quality certifications. Because we control the process from design through production, we have the flexibility to custom manufacture belts for any application.

PIX North America is the sales, service and distribution center for the United States, Canada and Mexico, offering over 40,000 different belts for a vast array of application and industries including agriculture, automotive, industrial, construction, lawn & garden, recreational vehicles, oil & gas, aggregate, mining, marine and HVAC. Our integrated production, service and warehousing capabilities ensure a robust stock and consistent timely delivery.



1 (855) 800-0720 / pixnorthamerica.com

BELT RANGE GUIDE

TABLE OF CONTENTS

Safety Policy, General Info & Warranty Information		3
WRAPPED V-BELTS		
X-SET®	Classical, Metric Wedge, Narrow, Light Duty Section	4
DURABAND®-XS	Banded Classical, Metric Wedge, Narrow Section	5
MUSCLE®-XS-3	High Power, Maintenance Free	6
GALLANT®-XS	Heavy Duty, High Power	7
LAWNMASTER®	Lawn Mower	8
FRAS®-XS	Fire Resistant & Anti-Static	9
IGLOO®-XS	Low Temperature	10
Special Construction Belts	CERAMICA®-XS, ECHELON®-XS, EXTRACTOR®-XS, PTU, TEXTURA®-XS, X'PRESS®-XS	11-12
DRYCOVER®-XS	Drycover	13
HARVESTER®-AGF	Agricultural Flat Belts	14
DUO®	Double Sided	15
RAW EDGE COGGED V-BELTS		
X'TRA®-XV	Classical, Metric Wedge, Narrow, Light Duty Section	16
DURABAND®-XS	Banded Classical, Metric Wedge, Narrow Section	17
MUSCLE®-XR-3	High Power	18
FRAS-XS®	Fire Resistant & Anti-Static	19
X'TRA®-XV	Variable Speed Belts	20
HARVESTER®-XV	Agricultural	21
POWERTEX®-XV2	Textile Machinery	21
RAW EDGE PLAIN, LAMINATED & ASYMMETRIC V-BELTS		
SPECTRA®-XR	Raw Edge Laminated, Center Corded	22
X'TRA®-XP & X'TRA®-XL	Raw Edge Plain & Raw Edge Laminated	22
ASYMMETRA®	Asymmetric	22
TIMING / SYNCHRONOUS BELTS		
X'ACT®	Classical, STD, HTD Section	23
X'ACT® OPEN-ENDED	Classical, STD, HTD Section	24
TORQUEPLUS®-XT2	High Power	25
DUO®-XT	Double Sided	25
SPECIALTY TIMING / SYNCHRONOUS BELTS		
TORQUEPLUS®-XT2 COTTON CLEANER	Cotton Cleaner	26
BRAWN®-XT	Hybrid Poly+Timing	26
TOPCOAT®-XT	Packaging Machinery	27
POLYURETHANE TIMING / SYNCHRONOUS BELTS		
XPEDIENT®-XT & XPEDIENT®-XT DBL Sided	Classical, Metric, STD, HTD Section	28 - 29
RIBBED / POLY V-BELTS		
X'CEED®	Ribbed / Poly V-Belts	30
FRAS-XC®	Fire Resistant & Anti-Static	30
THERMAL-XC®	High Temperature	30
DUO-XC®	Double Sided	31
POLYSTRETCH®-XC	Elasticated	31
TOPCOAT®-XC	Packaging Machinery	31
AUTOMOTIVE BELTS		
FORCE®	Raw Edge Cogged & Ribbed / Poly V-Belts	32
FORCE®	Timing Belts	33
SPRINTPRO®-XC	Application Specific	33
POWERSPORT BELTS		
WHITEKNIGHT®-XR	Application Specific	34
BELT ACCESSORIES		
CONVERSION CHARTS		
BELT DIMENSIONS		
		37 - 38

SAFETY POLICIES & GENERAL INFO

⚠ WARNING

Failure to observe the following Warnings could cause serious injury or death.

Belts can cause static electricity while in operation and ignite an explosive atmosphere. Special care must be taken when using belts in or near locations which accumulate dust, such as coal, grain or other combustible materials or that may contain explosive concentrations of combustible gases. The proper dissipation of such potential static electricity discharge must be assured to prevent any such explosion.

Aircraft Warning:

PIX Belts are not designed or intended for use in aircraft of any type unless otherwise noted. **Under no circumstances are PIX Belts to be used on helicopters, commercial, private, homebuilt or ultralight aircraft.**

Do not burn any belt, hazardous gas could be produced causing serious injury or death.

⚠ CAUTION

Failure to observe the following Cautions could cause property damage or a risk of serious physical injury.

Proper installation and selection of power transmission belts are critical. Belts must be properly selected and fitted to assure proper performance. Always follow equipment manufacturers installation, fitting directions and selection guides.

Do not use any belts beyond its capacity for an application other than specified by the catalog or design documents. This can cause premature failure of the belt.

If oil, water, chemicals, paint, dust or other materials that can stick to a belt or pulley can cause deterioration and the failure of the belt.

Do not use any PIX Belts in food grade equipment unless the belt is noted for that purpose.

LIMITED WARRANTY

All PIX Belts are guaranteed against manufacturers defects at time of shipment. Claims must be reported immediately to PIX North America specifying the type of defect and date of purchase. Any products found to be defective by a PIX representative are limited to replacement of product or refund of the original purchase price. PIX North America is not responsible for consequential damages and labor charges. Warranty does not cover deterioration due to normal wear, defects and damages due to alterations, negligence and use beyond safe operating limits. PIX North America's total liability shall not exceed the original purchase of the product.

Contact Us:

PIX North America aims for accuracy in all brochures and catalogs. If you locate an error or need additional information please contact PIX-NA's customer service team at 855.800.0720 or by email info@pixnorthamerica.com.

PIX Certifications:

ISO 9001 : 2008 ISO 14001 : 2004 ISO/TS 16949:2009
ISO/IEC 17025 : 2005 BS OHSAS 18001 : 2007

PIX North America is a proud member of:



CLASSICAL SECTION

Section	Top Width (in)	Thickness (in)	Angle (Degree)	Reference Standard	Minimum Pulley Dia. (in)	Mfg. Range (in)		Belt Length Factor (in)			Length Design
						Min.	Max.	Lp to La	Li to Lp	Li to La	
8	5/16"	3/16"	40	DIN 2215-1975	1 37/64"	39"	174"	15/32"	3/4"	1 7/32"	Li
Z	25/64"	15/64"	40	IS 2494, BS 3790, ISO 4184	1 31/32"	9 1/2"	176"	5/8"	7/8"	1 1/2"	Li
A / 4L	1/2"	5/16"	40	IS 2494, BS 3790, ISO 4184	2 51/64"	13"	357"	35/64"	1 27/64"	1 31/32"	Li
B / 5L	21/32"	7/16"	40	IS 2494, BS 3790, ISO 4184	4 13/32"	16"	900"	11/32"	1 45/64"	2 23/32"	Li
20	25/32"	1/2"	40	DIN 2215-1975	6 19/64"	31 1/2"	900"	1 15/64"	1 57/64"	3 7/64"	Li
C	7/8"	35/64"	40	IS 2494, BS 3790, ISO 4184	7 3/32"	31"	900"	1 1/4"	2 13/64"	3 15/32"	Li
25	1"	5/8"	40	DIN 2215-1975	9 27/32"	57"	900"	1 17/32"	2 13/32"	3 15/16"	Li
D	1 1/4"	3/4"	40	IS 2494, BS 3790, ISO 4184	13 63/64"	44 1/2"	920"	1 37/64"	3 7/64"	4 11/16"	Li
E	1 1/2"	29/32"	40	IS 2494	19 45/64"	90"	920"	2 3/32"	3 5/8"	5 23/32"	Li

These are primarily used in most industrial drives. Classical belts are recommended in special applications such as V-flat drives.

METRIC WEDGE SECTION

Section	Top Width (mm)	Thickness (mm)	Angle (Degree)	Reference Standard	Minimum Pulley Dia. (mm)	Mfg. Range (mm)		Belt Length Factor (mm)			Length Design
						Min.	Max.	Lp to La	Li to Lp	Li to La	
SPZ	10	8	40	BS 3790	63	365	4000	13	37	50	Lp
SPA	13	10	40	BS 3790	90	576	9110	18	45	63	Lp
SPB	17	14	40	BS 3790	140	1000	22943	28	60	88	Lp
19	19	15	40	DIN 7753	180	2253	9137	25	69	94	Lp
SPC	22	18	40	BS 3790	224	1861	22943	30	83	113	Lp

These are used extensively in many industrial applications ranging from a light duty application drive to heavy load applications.

NARROW SECTION

Section	Top Width (in)	Thickness (in)	Angle (Degree)	Reference Standard	Minimum Pulley Dia. (in)	Mfg. Range (in)		Belt Length Factor (in)			Length Design
						Min.	Max.	Lp to La	Li to Lp	Li to La	
3V	3/8"	5/16"	40	RMA IP 22	2 1/2"	19 1/2"	160"	33/64"	1 29/64"	1 31/32"	La
5V	5/8"	35/64"	40	RMA IP 22	5 1/2"	47"	920"	63/64"	2 3/8"	3 11/32"	La
8V	1"	29/32"	40	RMA IP 22	13 1/4"	100"	920"	2 3/32"	3 5/8"	5 23/32"	La

The 8V Section belts are commonly used in heavy duty applications (ie. stone crushers).

LIGHT DUTY SECTION

Section	Top Width (in)	Thickness (in)	Angle (Degree)	Reference Standard	Minimum Pulley Dia. (in)	Mfg. Range (in)		Belt Length Factor (in)			Length Design
						Min.	Max.	Lp to La	Li to Lp	Li to La	
3L	3/8"	1/4"	40	RMA IP 23	1 25/32"	10 1/2"	177"	5/8"	7/8"	1"	La

Light duty V-Belts are used in household appliances or in small size machines. They are primarily used in a single belt drives.

NOTE: 2L Belts are available in 2LX REP please reference page 22

FEATURES:

- Oil Resistant & Anti-static
- Max. belt linear speed

Classical	98 ft / sec
Wedge	137 ft / sec
Narrow	147 ft / sec
Light Duty	90 ft / sec
- Temperature Range 0°F to 176°F (-18°C to 80°C)
- ATEX certified FRAS Belts also available (see page 9)



APPLICATION:

Industrial drives such as pumps, generators, electric motors, ball-mills, crushers, compressors.

NOTE:

Intermediate sizes are available upon request.

DURABAND®-XS BANDED BELTS

CLASSICAL SECTION

Section	Top Width (in)	Thickness (in)	Angle (Degree)	Reference Standard	Pitch (in)	Minimum Pulley Dia. (in)	Mfg. Range (in)		Length Design
							Min.	Max.	
HA	1/2"	25/64"	40	ISO 5290, ISO 5291, BS 3790	5/8"	2 51/64"	33"	255"	Li
HB	21/32"	7/16"	40	ISO 5290, ISO 5291, BS 3790	3/4"	4 13/32"	43"	370"	Li
HC	7/8"	5/8"	40	ISO 5290, ISO 5291, BS 3790	1"	7 3/32"	47"	900"	Li
HD	1 1/4"	27/32"	40	ISO 5290, ISO 5291, BS 3790	1 7/16"	13 63/64"	90"	900"	Li

METRIC SECTION

Section	Top Width (mm)	Thickness (mm)	Angle (Degree)	Reference Standard	Pitch (mm)	Minimum Pulley Dia. (mm)	Mfg. Range (mm)		Length Design
							Min.	Max.	
HSPZ	10 mm	10 mm	40	ISO 5290, ISO 5291, BS 3790	12	63	1205	9080	Lp
HSPA	13 mm	12 mm	40	ISO 5290, ISO 5291, BS 3790	15	90	959	4515	Lp
HSPB	17 mm	16 mm	40	ISO 5290, ISO 5291, BS 3790	19	140	1762	9331	Lp
HSPC	22 mm	20 mm	40	ISO 5290, ISO 5291, BS 3790	25.5	224	2267	22943	Lp

NARROW SECTION

Section	Top Width (in)	Thickness (in)	Angle (Degree)	Reference Standard	Pitch (in)	Minimum Pulley Dia. (in)	Mfg. Range (in)		Length Design
							Min.	Max.	
H3V	3/8"	25/64"	40	ISO 5290, ISO 5291, BS 3790	13/32"	2 1/2"	37"	180"	La
H5V	5/8"	5/8"	40	ISO 5290, ISO 5291, BS 3790	11/16"	5 1/2"	51"	920"	La
H8V	1"	1"	40	ISO 5290, ISO 5291, BS 3790	1 1/8"	13 1/4"	100"	920"	La

FEATURES:

- Enhanced power transmission capacity up to 25%
- Lesser number of belts required as compared to multiple single-belt drive
- High adhesion strength between tie band and the belts
- Eliminates chances of mismatch in length as observed in multiple single belt drive
- Temperature Range 0°F to 176°F (-18°C to 80°C)
- Anti-static, oil and heat resistant
- Manufactured through single-stage curing process
- ATEX certified FRAS Belts also available (see page 9)

NOTE:

B, C, D, E, SPC & 8V section belts in single and banded constructions can be supplied up to 1000" or 25400 mm



APPLICATION:

Vertical shaft drives, agricultural drives, electric motors, stone crushers, compressors, generators.



MUSCLE[®]-XS3 HIGH POWER, MAINTENANCE-FREE V-BELTS

CLASSICAL SECTION

Section	Top Width (in)	Thickness (in)	Angle (Degree)	Reference Standard	Minimum Pulley Dia. (in)	Mfg. Range (in)		Belt Length Factor (in)			Length Design
						Min.	Max.	Lp to La	Li to Lp	Li to La	
A	1/2"	5/16"	40	IS 2494, BS 3790, ISO 4184	2 5/64"	13"	357"	5/9"	1 27/64"	1 31/32"	Li
B	21/32"	7/16"	40	IS 2494, BS 3790, ISO 4184	4 13/32"	16"	900"	1 1/32"	1 45/64"	2 23/32"	Li
C	7/8"	35/64"	40	IS 2494, BS 3790, ISO 4184	7 3/32"	31"	900"	1 1/4"	2 13/64"	3 15/32"	Li

METRIC WEDGE SECTION

Section	Top Width (mm)	Thickness (mm)	Angle (Degree)	Reference Standard	Minimum Pulley Dia. (mm)	Mfg. Range (mm)		Belt Length Factor (mm)			Length Design
						Min.	Max.	Lp to La	Li to Lp	Li to La	
SPZ	10	8	40	BS 3790	63	365	4000	13	37	50	Lp
SPA	13	10	40	BS 3790	90	576	9110	18	45	63	Lp
SPB	17	14	40	BS 3790	140	1000	22943	28	60	88	Lp
SPC	22	18	40	BS 3790	224	1861	22943	30	83	113	Lp

NARROW SECTION

Section	Top Width (in)	Thickness (in)	Angle (Degree)	Reference Standard	Minimum Pulley Dia. (in)	Mfg. Range (in)		Belt Length Factor (in)			Length Design
						Min.	Max.	Lp to La	Li to Lp	Li to La	
3V	3/8"	5/16"	40	RMA IP 22	2 1/2"	19 1/2"	160"	33/64"	1 29/64"	1 31/32"	La
5V	5/8"	35/64"	40	RMA IP 22	5 1/2"	47"	657"	63/64"	2 3/8"	3 11/32"	La
8V	1"	29/32"	40	RMA IP 22	13 1/4"	100"	905"	2 3/32"	3 5/8"	5 23/32"	La

FEATURES:

- Extremely high power rating - up to 50% more than regular belt
- High efficiency up to 98%
- Maintenance free & Anti-static that complies with ISO 1813
- Extended service life & less machine down-time
- Superior oil & heat resistance
- REACH & RoHS compliant, provides an Eco-friendly system
- Temperature Range -13°F to 212°F (-25°C - 100°C)

NOTE:

Intermediate sizes are available upon request.

Can be manufactured in banded construction upon request. Please contact your local sales representative or PIX North America for more information.

APPLICATION:

Compressors, industrial fans, vacuum pumps, presses, crushers, mixers, grinding machines, excavators, blowers, extruder's.



GALLANT® -XS HEAVY DUTY, HIGH POWER V-BELTS

CLASSICAL SECTION

Section	Top Width (in)	Thickness (in)	Angle (Degree)	Reference Standard	Minimum Pulley Dia. (in)	Mfg. Range (in)		Belt Length Factor (in)			Length Design
						Min.	Max.	Lp to La	Li to Lp	Li to La	
A	1/2"	5/16"	40	IS 2494, BS 3790, ISO 4184	2 51/64"	13"	357"	35/64"	1 27/64"	1 31/32"	Li
B	21/32"	7/16"	40	IS 2494, BS 3790, ISO 4184	4 13/32"	16"	900"	1 1/32"	1 45/64"	2 23/32"	Li
C	7/8"	5/9"	40	IS 2494, BS 3790, ISO 4184	7 3/32"	31"	900"	1 1/4"	2 13/64"	3 15/32"	Li

METRIC WEDGE SECTION

Section	Top Width (mm)	Thickness (mm)	Angle (Degree)	Reference Standard	Minimum Pulley Dia. (mm)	Mfg. Range (mm)		Belt Length Factor (mm)			Length Design
						Min.	Max.	Lp to La	Li to Lp	Li to La	
SPA	13	10	40	BS 3790	90	576	910	18	45	63	Lp
SPB	17	14	40	BS 3790	140	1000	16824	28	60	88	Lp
SPC	22	18	40	BS 3790	224	1861	22943	30	83	113	Lp

NARROW SECTION

Section	Top Width (in)	Thickness (in)	Angle (Degree)	Reference Standard	Minimum Pulley Dia. (in)	Mfg. Range (in)		Belt Length Factor (in)			Length Design
						Min.	Max.	Lp to La	Li to Lp	Li to La	
5V	5/8"	35/64"	40	RMA IP 22	5 1/2"	47"	657"	63/64"	2 3/8"	3 11/32"	La
8V	1"	19/21"	40	RMA IP 22	13 1/4"	100"	905"	2 3/32"	3 5/8"	5 23/32"	La

CLASSICAL SECTION BANDED BELTS

Section	Top Width (in)	Thickness (in)	Angle (Degree)	Reference Standard	Pitch (in)	Minimum Pulley Dia. (in)	Mfg. Range (in)		Length Design
							Min.	Max.	
HB	21/32"	7/16"	40	IS 2494, BS 3790, ISO 4184	3/4"	4 13/32"	43"	370"	Li
HC	7/8"	5/8"	40	IS 2494, BS 3790, ISO 4184	1"	7 3/32"	47"	900"	Li

METRIC SECTION BANDED BELTS

Section	Top Width (mm)	Thickness (mm)	Angle (Degree)	Reference Standard	Pitch (mm)	Minimum Pulley Dia. (mm)	Mfg. Range (mm)		Length Design
							Min.	Max.	
HSPA	13 mm	12 mm	40	BS 3790	15	90	959	4515	Lp
HSPB	17 mm	16 mm	40	BS 3790	19	140	1762	9331	Lp
HSPC	22 mm	20 mm	40	BS 3790	25.5	224	2267	22943	Lp

NARROW SECTION BANDED BELTS

Section	Top Width (in)	Thickness (in)	Angle (Degree)	Reference Standard	Pitch (in)	Minimum Pulley Dia. (in)	Mfg. Range (in)		Length Design
							Min.	Max.	
H5V	5/8"	5/8"	40	RMA IP 22	11/16"	5 1/2"	51"	663"	La
H8V	1"	1"	40	RMA IP 22	1 1/8"	13 1/4"	100"	905"	La

FEATURES:

- Enhanced power transmission capacity
 - Up to 40% in PIX-Gallant® Single Belts
 - Up to 55% in PIX-Gallant®-HXS Banded Belts
- Especially treated outer tough cover reduces sidewall wear and with stands to sudden shear forces at peak loads
- Designed to exhibit excellent durability, strength, abrasion and wear resistance
- Unique performance under heavy shocks and impulse loads
- Low heat generation even at very high speed
- Best solution for compact drives as lesser number of belts is required
- One single branding that combines all the major features and fit for any robust application
- Temperature Range -13°F to 212°F (-25°C to 100°C)

APPLICATIONS:

Mining, aggregate and forestry



LAWNMASTER® -XS SERIES Dupont™ Kevlar® V-BELTS

Section	Top Width (in)	Thickness (in)	Angle (Degree)	Reference Standard	Minimum Pulley Dia. (in)	Mfg. Range (in)		Length Design
						Min.	Max.	
3L	3/8"	1/4"	40	RMA IP 23	1 3/4"	10 1/2"	177"	La
A / 4L	1/2"	5/16"	40	RMA IP 23	2 9/16"	15"	359"	La
B / 5L	5/8"	3/8"	40	RMA IP 23	3 19/32"	21"	242"	La

FEATURES:

- Contains Dupont™ Kevlar® fiber for high tensile strength, non-extensibility, and high resistance to shock loads
- High resistance to wear and tear, reduced slippage while clutching
- Able to withstand high level of reverse flexing
- High resistance to oil, heat and cracking
- Temperature Range 0°F to 176°F (-18°C to 80°C)



APPLICATION:

Lawn & garden machinery

NOTE:

Intermediate sizes and OEM replacement belts are available upon request.



PIX offers the largest selection of OEM exact replacement belts for Lawn & Garden, Agricultural and Turf applications for most brands.

PIX exact OEM replacement belts are made to meet or exceed quality standards of OEM belts.



DuPont™ and Kevlar® are trademarks or registered trademarks of E.I. du Pont de Nemours and Company.

FRAS® -XS FIRE RESISTANT & ANTI-STATIC V-BELTS

CLASSICAL SECTION

Section	Top Width (in)	Thickness (in)	Angle (Degree)	Reference Standard	Minimum Pulley Dia. (in)	Mfg. Range (in)		Belt Length Factor (in)			Length Design
						Min.	Max.	Lp to La	Li to Lp	Li to La	
8	5/16"	3/16"	40	DIN 2215-1975	1 37/64"	39"	174"	15/32"	3/4"	1 7/32"	Li
Z	25/64"	15/64"	40	IS 2494, BS 3790, ISO 4184	1 31/32"	9 1/2"	176"	5/8"	7/8"	1 1/2"	Li
A	1/2"	5/16"	40	IS 2494, BS 3790, ISO 4184	2 51/64"	13"	357"	35/64"	1 27/64"	1 31/32"	Li
B	21/32"	7/16"	40	IS 2494, BS 3790, ISO 4184	4 13/32"	16"	900"	1 1/32"	1 45/64"	2 23/32"	Li
20	25/32"	1/2"	40	DIN 2215-1975	6 19/64"	31 1/2"	900"	115/64"	1 57/64"	3 7/64"	Li
C	7/8"	35/64"	40	IS 2494, BS 3790, ISO 4184	7 3/32"	31"	900"	1 1/4"	2 13/64"	3 15/32"	Li
25	1"	5/8"	40	DIN 2215-1975	9 27/32"	57"	900"	117/32"	2 13/32"	3 15/16"	Li
D	1 1/4"	3/4"	40	IS 2494, BS 3790, ISO 4184	13 63/64"	44 1/2"	920"	1 37/64"	3 7/64"	4 11/16"	Li
E	1 1/2"	29/32"	40	IS 2494	19 45/64"	90"	920"	2 3/32"	3 5/8"	5 23/32"	Li

METRIC WEDGE SECTION

Section	Top Width (mm)	Thickness (mm)	Angle (Degree)	Reference Standard	Minimum Pulley Dia. (mm)	Mfg. Range (mm)		Belt Length Factor (mm)			Length Design
						Min.	Max.	Lp to La	Li to Lp	Li to La	
SPZ	10	8	40	BS 3790	63	365	4000	13	37	50	Lp
SPA	13	10	40	BS 3790	90	576	9110	18	45	63	Lp
SPB	17	14	40	BS 3790	140	1000	22943	28	60	88	Lp
19	19	15	40	DIN 7753	180	2253	9137	25	69	94	Lp
SPC	22	18	40	BD 3790	224	1861	22943	30	83	113	Lp

NARROW SECTION

Section	Top Width (in)	Thickness (in)	Angle (Degree)	Reference Standard	Minimum Pulley Dia. in.	Mfg. Range (in)		Belt Length Factor (in)			Length Design
						Min.	Max.	Lp to La	Li to Lp	Li to La	
3V	3/8"	5/16"	40	RMA IP 22	2 1/2"	19 1/2"	160"	33/64"	1 29/64"	1 31/32"	La
5V	5/8"	35/64"	40	RMA IP 22	5 1/2"	47"	920"	63/64"	2 3/8"	3 11/32"	La
8V	1"	29/32"	40	RMA IP 22	13 1/4"	100"	920"	2 3/32"	3 5/8"	5 23/32"	La

CLASSICAL & NARROW SECTION BANDED BELTS

Section	Top Width (in)	Thickness (in)	Angle (Degree)	Reference Standard	Pitch (in)	Minimum Pulley Dia. (in)	Mfg. Range (in)		Length Design
							Min.	Max.	
HA	1/2"	25/64"	40	IS 2494, BS 3790, ISO 4184	5/8"	2 51/64"	33"	255"	Li
HB	21/32"	7/16"	40	IS 2494, BS 3790, ISO 4184	3/4"	4 13/32"	43"	370"	Li
HC	7/8"	5/8"	40	IS 2494, BS 3790, ISO 4184	1"	7 3/32"	47"	900"	Li
HD	1 1/4"	27/32"	40	IS 2494, BS 3790, ISO 4184	1 7/16"	13 63/64"	90"	900"	Li
H3V	3/8"	25/64"	40	RMA IP 22	13/32"	2 1/2"	37"	180"	La
H5V	5/8"	5/8"	40	RMA IP 22	11/16"	5 1/2"	51"	920"	La
H8V	1"	1"	40	RMA IP 22	1 1/8"	13 1/4"	100"	920"	La

METRIC SECTION BANDED BELTS

Section	Top Width (mm)	Thickness (mm)	Angle (Degree)	Reference Standard	Pitch (mm)	Minimum Pulley Dia. (mm)	Mfg. Range (mm)		Length Design
							Min.	Max.	
HSPZ	10 mm	10 mm	40	BS 3790	12	63	1205	9080	Lp
HSPA	13 mm	12 mm	40	BS 3790	15	90	959	4515	Lp
HSPB	17 mm	16 mm	40	BS 3790	19	140	1762	9331	Lp
HSPC	22 mm	20 mm	40	BS 3790	25.5	224	2267	22943	Lp

FEATURES:

- Ensures high level of protection against fire hazards
- Fire resistance properties complies per IS 2494 Part-II standard
- Anti-static values found 10 to 15 times lower than the maximum specific value, as per ISO 1813
- All FRAS Belts are certified by ATEX

- Resistance to emit inflammable substances while in operation
- Damage-free and crack resistance properties to ensure smooth operation
- Longer service life
- Dimensional stability
- Anti-static, oil and heat resistant
- Temperature Range 0°F to 176°F (-18°C to 80°C)

APPLICATIONS:

Coal mines, fire-prone areas, petrochemical installations



IGLOO® -XS LOW TEMPERATURE V-BELTS

CLASSICAL SECTION

Section	Top Width (in)	Thickness (in)	Angle (Degree)	Reference Standard	Minimum Pulley Dia. (in)	Mfg. Range (in)		Belt Length Factor (in)			Length Design
						Min.	Max.	Lp to La	Li to Lp	Li to La	
Z	25/64"	15/64"	40	IS 2494, BS 3790, ISO 4184	1 31/32"	9 1/2"	176"	5/8"	7/8"	1 1/2"	Li
A	1/2"	5/16"	40	IS 2494, BS 3790, ISO 4184	2 51/64"	13"	357"	35/64"	1 27/64"	1 31/32"	Li
B	21/32"	7/16"	40	IS 2494, BS 3790, ISO 4184	4 13/32"	16"	900"	1 1/32"	1 45/64"	2 23/32"	Li
C	7/8"	35/64"	40	IS 2494, BS 3790, ISO 4184	7 3/32"	31"	900"	1 1/4"	2 13/64"	3 15/32"	Li

METRIC WEDGE SECTION

Section	Top Width (mm)	Thickness (mm)	Angle (Degree)	Reference Standard	Minimum Pulley Dia. (mm)	Mfg. Range (mm)		Belt Length Factor (mm)			Length Design
						Min.	Max.	Lp to La	Li to Lp	Li to La	
SPZ	10	8	40	BS 3790	63	365	4000	13	37	50	Lp
SPA	13	10	40	BS 3790	90	576	9110	18	45	63	Lp
SPB	17	14	40	BS 3790	140	1000	22943	28	60	88	Lp
SPC	22	18	40	BS 3790	224	1861	22943	30	83	113	Lp

NARROW SECTION

Section	Top Width (in)	Thickness (in)	Angle (Degree)	Reference Standard	Minimum Pulley Dia. (in)	Mfg. Range (in)		Belt Length Factor (in)			Length Design
						Min.	Max.	Lp to La	Li to Lp	Li to La	
3V	3/8"	5/16"	40	RMA IP 22	2 1/2"	19 1/2"	160"	33/64"	1 29/64"	1 31/32"	La
5V	5/8"	35/64"	40	RMA IP 22	5 1/2"	47"	920"	63/64"	2 3/8"	3 11/32"	La
8V	1"	29/32"	40	RMA IP 22	13 1/4"	100"	920"	2 3/32"	3 5/8"	5 23/32"	La

CLASSICAL & NARROW SECTION BANDED BELTS

Section	Top Width (in)	Thickness (in)	Angle (Degree)	Reference Standard	Pitch (in)	Minimum Pulley Dia. (in)	Mfg. Range (in)		Length Design
							Min.	Max.	
HA	1/2"	25/64"	40	IS 2494, BS 3790, ISO 4184	5/8"	2 51/64"	33"	255"	Li
HB	21/32"	7/16"	40	IS 2494, BS 3790, ISO 4184	3/4"	4 13/32"	43"	370"	Li
HC	7/8"	5/8"	40	IS 2494, BS 3790, ISO 4184	1"	7 3/32"	47"	900"	Li
H3V	3/8"	25/64"	40	RMA IP 22	13/32"	2 1/2"	37"	180"	La
H5V	5/8"	5/8"	40	RMA IP 22	11/16"	5 1/2"	51"	920"	La
H8V	1"	1"	40	RMA IP 22	1 1/8"	13 1/4"	100"	920"	La

METRIC SECTION BANDED BELTS

Section	Top Width (mm)	Thickness (mm)	Angle (Degree)	Reference Standard	Pitch (mm)	Minimum Pulley Dia. (mm)	Mfg. Range (mm)		Length Design
							Min.	Max.	
HSPZ	10 mm	10 mm	40	BS 3790	12	63	1205	9080	Lp
HSPA	13 mm	12 mm	40	BS 3790	15	90	959	4515	Lp
HSPB	17 mm	16 mm	40	BS 3790	19	140	1762	9331	Lp
HSPC	22 mm	20 mm	40	BS 3790	25.5	224	2267	22943	Lp

FEATURES:

- Excellent performance while operating in extremely low ambient temperatures
- Longer service life
- Smooth-running operation
- Improved crack resistance properties to ensure smooth operation in low temperature applications
- Temperature Range -49°F to 176°F (-45°C to 80°C)

APPLICATION:

Cooling tunnels, cold storage for conveying purpose, low ambient temperature drives.



PIX® LOW TEMPERATURE V-BELTS

SPECIAL CONSTRUCTION BELTS

CERAMICA[®]-XS (PT-6)

Section	Top Width (in)	Thickness (in)	Pattern Height (in)	Angle (Degree)	Mfg. Range (in)		Length Design
					Min.	Max.	
B	21/32"	7/8"	7/16"	40	85"	357"	Li
B	21/32"	1"	5/8"	40	66"	356"	Li
C	7/8"	1"	7/16"	40	73"	320"	Li

FEATURES:

- Excellent service life
- Strong adhesion between top profile and the belt
- Application specific designed belts
- Designed for applications where power transmission & conveying of material is done simultaneously
- Temperature Range 0°F to 176°F (-18°C to 80°C)

APPLICATION: Ceramic industry



ECHELON[®]-XS (PTO)

Section	Top Width (in)	Thickness (in)	Pattern Height (in)	Angle (Degree)	Mfg. Range (in)		Length Design
					Min.	Max.	
A	1/2"	1/2"	3/16"	40	48"	356"	Li
B	21/32"	9/16"	1/8"	40	85"	900"	Li
B	21/32"	5/8"	3/16"	40	85"	900"	Li
37 x 25	17/16"	1"	3/16"	40	161"	900"	Li

FEATURES:

- Excellent service life
- Strong adhesion between top profile and the belt
- Application specific designed belts
- Designed for applications where power transmission & conveying of material is done simultaneously
- Temperature Range 0°F to 176°F (-18°C to 80°C)

APPLICATION: Food grain, packaging and ceramic industry



EXTRACTOR[®]-XS (PT-7)

Section	Top Width (in)	Thickness (in)	Pattern Height (in)	Angle (Degree)	Mfg. Range (in)		Length Design
					Min.	Max.	
D	1 1/4"	1"	9/32"	40	142"	900"	Li
37 x 25	17/16"	1"	9/32"	40	116"	375"	Li

FEATURES:

- Excellent service life
- Strong adhesion between top profile and the belt
- Application specific designed belts
- Designed for applications where power transmission & conveying of material is done simultaneously
- Temperature Range 0°F to 176°F (-18°C to 80°C)

APPLICATION: Carrot harvesting machines, Horticultural industry

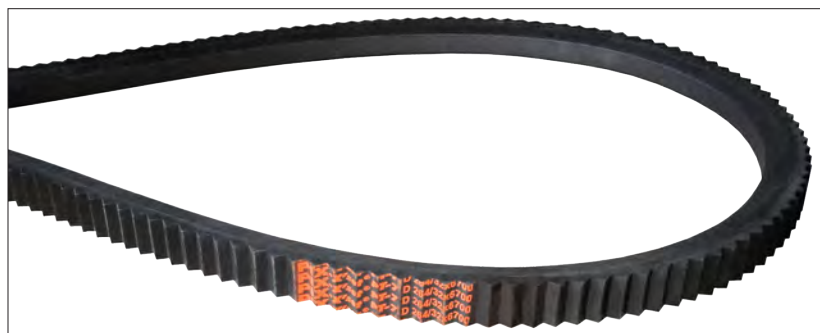

SPECIAL CONSTRUCTION BELTS

PTU

Section	Top Width (in)	Thickness (in)	Pattern Height (in)	Angle (Degree)	Mfg. Range (in)		Length Design
					Min.	Max.	
B	21/32"	5/8"	7/32"	40	36.5"		Li

FEATURES:

- Excellent service life
- Strong adhesion between top profile and the belt
- Application specific designed belts
- Designed for applications where power transmission & conveying of material is done simultaneously
- Temperature Range 0°F to 176°F (-18°C to 80°C)

APPLICATION: Wheel Chairs



TEXTURA® -XS (PT-HC)

Section	Top Width (in)	Thickness (in)	Pattern Height (in)	Angle (Degree)	Mfg. Range (in)		Length Design
					Min.	Max.	
B	21/32"	11/16"	1/4"	40	42"	900"	Li
C	7/8"	13/16"	1/4"	40	66"	900"	Li

FEATURES:

- Excellent service life
- Strong adhesion between top profile and the belt
- Application specific designed belts
- Designed for applications where power transmission & conveying of material is done simultaneously
- Temperature Range 0°F to 176°F (-18°C to 80°C)

APPLICATION: Ceramic and general industries



X'PRESS® -XS

Section	Top Width (in)	Thickness (in)	Pattern Height (in)	Angle (Degree)	Mfg. Range (in)		Length Design
					Min.	Max.	
20 x 12.5	13/16"	5/8"	3/32"	40	155"	900"	Li

FEATURES:

- Excellent service life
- Strong adhesion between top profile and the belt
- Application specific designed belts
- Designed for applications where power transmission & conveying of material is done simultaneously
- Temperature Range 0°F to 176°F (-18°C to 80°C)

APPLICATION: Ceramic and general industries



DRYCOVER[®]-XS

CLASSICAL SECTION

Section	Top Width (in)	Thickness (in)	Angle (Degree)	Reference Standard	Minimum Pulley Dia. (in)	Mfg. Range (in)		Belt Length Factor (in)			Length Design
						Min.	Max.	Lp to La	Li to Lp	Li to La	
A	1/2"	5/16"	40	IS 2494, BS 3790, ISO 4184	2 51/64"	13"	357"	35/64"	1 27/64"	1 31/32"	Li
B	21/32"	7/16"	40	IS 2494, BS 3790, ISO 4184	4 13/32"	16"	900"	1 1/32"	1 45/64"	2 23/32"	Li
C	7/8"	35/64"	40	IS 2494, BS 3790, ISO 4184	7 3/32"	31"	900"	1 1/4"	2 13/64"	3 15/32"	Li
D	1 1/4"	3/4"	40	IS 2494, BS 3790, ISO 4184	13 63/64"	44 1/2"	900"	1 37/64"	3 7/64"	4 11/16"	Li

METRIC WEDGE SECTION

Section	Top Width (mm)	Thickness (mm)	Angle (Degree)	Reference Standard	Minimum Pulley Dia. (mm)	Mfg. Range (mm)		Belt Length Factor (mm)			Length Design
						Min.	Max.	Lp to La	Li to Lp	Li to La	
SPZ	10	8	40	BS 3790	63	365	4000	13	37	50	Lp
SPA	13	10	40	BS 3790	90	576	910	18	45	63	Lp
SPB	17	14	40	BS 3790	140	1000	22943	28	60	88	Lp
SPC	22	18	40	BS 3790	224	1861	22943	30	83	113	Lp

NARROW SECTION

Section	Top Width (in)	Thickness (in)	Angle (Degree)	Reference Standard	Minimum Pulley Dia. (in)	Mfg. Range (in)		Belt Length Factor (in)			Length Design
						Min.	Max.	Lp to La	Li to Lp	Li to La	
3V	3/8"	5/16"	40	RMA IP 22	2 1/2"	19 1/2"	160"	33/64"	1 29/64"	1 31/32"	La
5V	5/8"	35/64"	40	RMA IP 22	5 1/2"	47"	920"	63/64"	2 3/8"	3 11/32"	La
8V	1"	19/21"	40	RMA IP 22	13 1/4"	100"	920"	2 3/32"	3 5/8"	5 23/32"	La

LIGHT DUTY SECTION

Section	Top Width (in)	Thickness (in)	Angle (Degree)	Reference Standard	Minimum Pulley Dia. (in)	Mfg. Range (in)		Belt Length Factor (in)			Length Design
						Min.	Max.	Lp to La	Li to Lp	Li to La	
3L	3/8"	1/4"	40	RMA IP 22	1 25/32"	10 1/2"	177"	5/8"	7/8"	1 1/2"	La
4L	1/2"	5/16"	40	RMA IP 22	2 9/16"	15"	359"	9/16"	1 27/64"	1 31/32"	La
5L	5/8"	3/8"	40	RMA IP 22	3 19/32"	21"	242"	1 1/32"	1 45/64"	2 23/32"	La

FEATURES:

- Suitable for drives having clutch applications
- Designed for applications where contamination is not accepted
- Available in Kevlar[®] and polyester cord construction
- Different colors available in - blue, green, brown, red, black & white
- Temperature Range 0°F to 176°F (-18°C to 80°C)

APPLICATION:

Chemical, pharmaceuticals, food industry



DuPont[™] and Kevlar[®] are trademarks or registered trademarks of E.I. du Pont de Nemours and Company.

Section	Top Width (mm)	Thickness (mm)	Mfg. Range (in)		Length Design
			Min.	Max.	
30Fx6	30	6	110"	900"	Li
50Fx6	50	6	39"	80"	Li
75Fx6	75	6	106"	352"	Li
80Fx6	80	6	77"	340"	Li
95Fx6	95	6	106"	315"	Li
100Fx6	100	6	85"	352"	Li
114Fx6	114	6	106"	317"	Li
120Fx6	120	6	106"	317"	Li
125Fx6	125	6	68"	252"	Li
127Fx6	127	6	106"	317"	Li
135Fx6	135	6	106"	342"	Li
140Fx6	140	6	106"	342"	Li
150Fx6	150	6	106"	317"	Li

FEATURES:

- Specialty designed for application with outside idlers
- Highly flexible, suitable for small pulley diameters
- Higher power transmission than regular belts
- Excellent performance under variable load conditions.
- Temperature Range 0°F to 176°F (-18°C to 80°C)

NOTE:

Intermediate sizes are available upon request.



DUO[®]-XS HEXAGONAL DOUBLE SIDE BELTS

Section	Top Width (in)	Thickness (in)	Angle (Degree)	Minimum Pulley Dia. (in)	Mfg. Range (in)		Length Design
					Min.	Max.	
AA	1/2"	25/64"	40	3 1/8"	46"	254"	Le
BB	21/32"	35/64"	40	4 15/16"	40"	900"	Le
CC	7/8"	21/32"	40	8 7/8"	73"	900"	Le
25	1"	7/8"	40	11"	88"	900"	Le
DD	1 1/4"	1"	40	14"	158"	900"	Le

DUO[®]-XS-N HEXAGONAL DOUBLE SIDE NOTCHED BELTS

Section	Top Width (in)	Thickness (in)	Angle (Degree)	Minimum Pulley Dia. (in)	Mfg. Range (in)		Length Design
					Min.	Max.	
AA-N	1/2"	5/16"	40	3 1/8"	46"	254"	Lp
BB-N	21/32"	35/64"	40	4 15/16"	40"	254"	Lp
CC-N	7/8"	21/32"	40	8 7/8"	155"	900"	Lp

FEATURES:

- Absolutely flexible
- Transmit power from both the sides
- This special construction allow belt to be used in "Serpentine-drive" system
- Temperature Range 0°F to 176°F (-18°C to 80°C)

APPLICATION:

Hexagonal belts finds application in the drives where several pulleys in the same plane are to be driven in clockwise and anti-clockwise directions, simultaneously. The polyester tension cord placed at the center of the construction provides extreme flexibility and low stretch properties. Because of specific cord positioning, the belts are not subjected to any other forces, as in the case of normal V-Belts. These are also used in rice mills and poultry processing. However, as of late these belts are also used in industrial drives.



DUO[®]-XR HEXAGONAL DOUBLE SIDED COG BELTS

Section	Top Width (in)	Thickness (in)	Angle (Degree)	Minimum Pulley Dia. (in)	Mfg. Range (in)		Length Design
					Min.	Max.	
AAX	1/2"	5/16"	36	2 3/8"	31.5"	118"	Li
BBX	21/32"	35/64"	36	3 11/32"	29.5"	200"	Li
CCX	7/8"	21/32"	36	5 1/2"	39.5"	118"	Li

FEATURES:

- Absolutely flexible
- Transmit power from both the sides
- This special construction allow belt to be used in "Serpentine-drive" system
- Temperature Range -13°F to 212°F (-25°C to 100°C)

APPLICATION:

Food Processing Mills



CLASSICAL SECTION

Section	Top Width (in)	Thickness (in)	Angle (Degree)	Reference Standard	Minimum Pulley Dia. (in)	Mfg. Range (in)		Belt Length Factor (in)			Length Design
						Min.	Max.	Lp to La	Li to Lp	Li to La	
ZX	25/64"	15/64"	36	IS 2494, BS 3790, ISO 4184	1 37/64"	21 1/2"	200"	5/8"	7/8"	1 1/2"	Li
AX	1/2"	5/16"	36	IS 2494, BS 3790, ISO 4184	2 1/2"	21 1/2"	200"	35/64"	1 27/64"	1 31/32"	Li
BX	21/32"	7/16"	36	IS 2494, BS 3790, ISO 4184	3 1/2"	21 1/2"	200"	11/32"	1 45/64"	2 23/32"	Li
CX	7/8"	35/64"	36	IS 2494, BS 3790, ISO 4184	5 1/2"	23 1/2"	200"	11/4"	2 13/64"	3 15/32"	Li
DX	1 1/4"	3/4"	36	IS 2494, BS 3790, ISO 4184	11"	40"	200"	1 37/64"	3 7/64"	4 11/16"	Li

METRIC WEDGE SECTION

Section	Top Width (mm)	Thickness (mm)	Angle (Degree)	Reference Standard	Minimum Pulley Dia. (mm)	Mfg. Range (mm)		Belt Length Factor (mm)			Length Design
						Min.	Max.	Lp to La	Li to Lp	Li to La	
XPZ	10	8	36	IS 2494, BS 3790, ISO 4184	56	550	5100	13	37	50	Lp
XPA	13	10	36	IS 2494, BS 3790, ISO 4184	71	550	5100	18	45	63	Lp
XPB	17	14	36	IS 2494, BS 3790, ISO 4184	112	550	5100	28	60	88	Lp
XPC	22	18	38	IS 2494, BS 3790, ISO 4184	180	600	5100	30	83	113	Lp

NARROW SECTION

Section	Top Width (in)	Thickness (in)	Angle (Degree)	Reference Standard	Minimum Pulley Dia. (in)	Mfg. Range (in)		Belt Length Factor (in)			Length Design
						Min.	Max.	Lp to La	Li to Lp	Li to La	
3VX	3/8"	5/16"	38	RMA IP 22	2 13/64"	23 1/2"	200"	33/64"	1 29/64"	1 31/32"	La
5VX	5/8"	35/64"	38	RMA IP 22	4 13/32"	23 1/2"	200"	63/64"	2 3/8"	3 11/32"	La
8VX	1"	29/32"	38	RMA IP 22	10"	90"	200"	2 3/32"	3 5/8"	5 23/32"	La

LIGHT DUTY SECTION

Section	Top Width (in)	Thickness (in)	Angle (Degree)	Reference Standard	Minimum Pulley Dia. (in)	Mfg. Range (in)		Belt Length Factor (in)			Length Design
						Min.	Max.	Lp to La	Li to Lp	Li to La	
3LX	3/8"	1/4"	36	RMA IP 23	1 27/64"	21 1/2"	200"	5/8"	7/8"	1 1/2"	La
4LX	1/2"	5/16"	36	RMA IP 23	2 9/32"	21 1/2"	200"	9/16"	1 27/64"	1 31/32"	La
5LX	5/8"	3/8"	36	RMA IP 23	2 53/64"	21 1/2"	200"	11/32"	1 45/64"	2 23/32"	La

NOTE: 2LX Belts are available in 2LX REP please reference page 22

FEATURES:

- Oil Resistant & Anti-static
- Max. belt linear speed

Classical	98 ft / sec
Wedge	137 ft / sec
Narrow	147 ft / sec
Light Duty	90 ft / sec
- Higher power transmission capacity than wrapped belts
- Superior transverse stiffness & high wear resistance
- Suitable for drives with small pulley diameter, high ambient temperature & speed
- Temperature Range -13°F to 212°F (-25°C to 100°C)
- ATEX certified FRAS Belts also available (see page 19)



APPLICATION:

Industrial drives such as pumps, generators, electric motors, ball-mills, crushers, compressors.

NOTE:

Intermediate sizes are available upon request.

DURABAND[®]-XR RAW EDGE COGGED BANDED BELTS

CLASSICAL SECTION

Section	Top Width (in)	Thickness (in)	Angle (Degree)	Reference Standard	Pitch (in)	Mfg. Range (in)		Length Design
						Min.	Max.	
HAX	1/2"	25/64"	36	ISO 5290, ISO 5291, BS 3790	5/8"	23 1/2"	200"	Li
HBX	21/32"	1/2"	36	ISO 5290, ISO 5291, BS 3790	3/4"	23 1/2"	200"	Li
HCX	7/8"	5/8"	36	ISO 5290, ISO 5291, BS 3790	1"	23 1/2"	200"	Li

METRIC SECTION

Section	Top Width (mm)	Thickness (mm)	Angle (Degree)	Reference Standard	Pitch (mm)	Mfg. Range (mm)		Length Design
						Min.	Max.	
HXPZ	10 mm	10 mm	36	ISO 5290, ISO 5291, BS 3790	12	600	5100	Lp
HXPA	13 mm	12 mm	36	ISO 5290, ISO 5291, BS 3790	15	600	5100	Lp
HXPB	17 mm	16 mm	36	ISO 5290, ISO 5291, BS 3790	19	600	5100	Lp
HXPC	22 mm	20 mm	36	ISO 5290, ISO 5291, BS 3790	25.5	600	5100	Lp

NARROW SECTION

Section	Top Width (in)	Thickness (in)	Angle (Degree)	Reference Standard	Pitch (in)	Mfg. Range (in)		Length Design
						Min.	Max.	
H3VX	3/8"	25/64"	36	ISO 5290, ISO 5291, BS 3790	13/32"	23 1/2"	200"	La
H5VX	5/8"	5/8"	36	ISO 5290, ISO 5291, BS 3790	11/16"	23 1/2"	200"	La

FEATURES:

- Enhanced power transmission capacity up to 25%
- Lesser number of belts required as compared to multiple single-belt drive
- Eliminates chances of mismatch in length as observed in multiple single Belt drive
- Temperature Range -13°F to 212°F (-25°C to 100°C)
- Anti-static, oil and heat resistant
- Manufactured through single-stage curing process
- ATEX certified FRAS Belts also available (see page 19)

APPLICATION:

Best suited for drives with severe vibrations, vertical shaft drives, V-flat drives, agricultural drives, stone crushers, heavy duty compressors, generator sets, pumps, cold forging machines & mining equipment.

NOTE:

Intermediate sizes are available upon request.

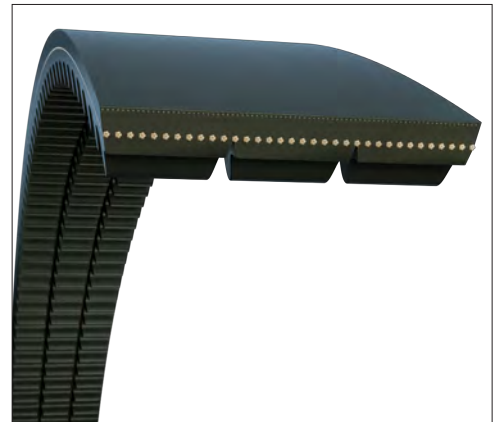

MUSCLE® -XR3 HIGH POWER, MAINTENANCE FREE COGGED BELTS

CLASSICAL SECTION

Section	Top Width (in)	Thickness (in)	Angle (Degree)	Reference Standard	Minimum Pulley Dia. (in)	Mfg. Range (in)		Belt Length Factor (in)			Length Design
						Min.	Max.	Lp to La	Li to Lp	Li to La	
AX	1/2"	5/16"	36	IS 2494, BS 3790, ISO 4184	2 1/2"	23 1/2"	200"	35/64"	1 27/64"	1 31/32"	Li
BX	21/32"	7/16"	36	IS 2494, BS 3790, ISO 4184	3 1/2"	23 1/2"	200"	11/32"	1 45/64"	2 23/32"	Li
CX	7/8"	35/64"	36	IS 2494, BS 3790, ISO 4184	5 1/2"	23 1/2"	200"	1 1/4"	2 13/64"	3 15/32"	Li

METRIC SECTION

Section	Top Width (mm)	Thickness (mm)	Angle (Degree)	Reference Standard	Minimum Pulley Dia. (mm)	Mfg. Range (mm)		Belt Length Factor (mm)			Length Design
						Min.	Max.	Lp to La	Li to Lp	Li to La	
XPZ	10	8	36	IS 2494, BS 3790, ISO 4184	56	600	5100	13	37	50	Lp
XPA	13	10	36	IS 2494, BS 3790, ISO 4184	71	600	5100	18	45	63	Lp
XPB	17	14	36	IS 2494, BS 3790, ISO 4184	112	600	5100	28	60	88	Lp
XPC	22	18	38	IS 2494, BS 3790, ISO 4184	180	600	5100	30	83	113	Lp

NARROW SECTION

Section	Top Width (in)	Thickness (in)	Angle (Degree)	Reference Standard	Minimum Pulley Dia. (in)	Mfg. Range (in)		Belt Length Factor (in)			Length Design
						Min.	Max.	Lp to La	Li to Lp	Li to La	
3VX	3/8"	5/16"	38	RMA IP 22	2 13/64"	23 1/2"	200"	33/64"	1 29/64"	1 31/32"	La
5VX	5/8"	35/64"	38	RMA IP 22	4 13/32"	23 1/2"	200"	63/64"	2 3/8"	3 11/32"	La

FEATURES:

- Extremely high power rating - up to 50% more than standard V-belt
- High efficiency up to 98% providing optimum output
- Maintenance free
- Extended service life & less machine down-time with minimal belt tension loss
- Anti-static complies with ISO 1813
- High dimensional stability offering the best wedging effect between the belt and the pulley flanges
- REACH & RoHS compliant, provides an Eco-friendly system
- Extended Temperature Range
-31°F to 266°F (-35°C to 130°C)



APPLICATIONS:

Textile mills, machine tools, food processing applications, compressors, industrial fans, vacuum pumps, presses, crushers, mixers, grinding machines, excavators, blowers, extruder's.



PIX® HIGH POWER, MAINTENANCE-FREE BELTS

FRAS[®] -XR FIRE RESISTANT, ANTI-STATIC COGGED BELTS

CLASSICAL SECTION

Section	Top Width (in)	Thickness (in)	Angle (Degree)	Reference Standard	Minimum Pulley Dia. (in)	Mfg. Range (in.)		Belt Length Factor (in)			Length Design
						Min.	Max.	Lp to La	Li to Lp	Li to La	
ZX	25/64"	15/64"	36	IS 2494, BS 3790, ISO 4184	1 37/64"	21 1/2"	200"	5/8"	7/8"	1 1/2"	Li
AX	1/2"	5/16"	36	IS 2494, BS 3790, ISO 4184	2 1/2"	21 1/2"	200"	35/64"	1 27/64"	1 31/32"	Li
BX	21/32"	7/16"	36	IS 2494, BS 3790, ISO 4184	3 1/2"	21 1/2"	200"	1 1/32"	1 45/64"	2 23/32"	Li
CX	7/8"	35/64"	36	IS 2494, BS 3790, ISO 4184	5 1/2"	23 1/2"	200"	1 1/4"	2 13/64"	3 15/32"	Li

METRIC SECTION

Section	Top Width (mm)	Thickness (mm)	Angle (Degree)	Reference Standard	Minimum Pulley Dia. (mm)	Mfg. Range (mm)		Belt Length Factor (mm)			Length Design
						Min.	Max.	Lp to La	Li to Lp	Li to La	
XPZ	10	8	36	IS 2494, BS 3790, ISO 4184	56	550	5100	13	37	50	Lp
XPA	13	10	36	IS 2494, BS 3790, ISO 4184	71	550	5100	18	45	63	Lp
XPB	17	14	36	IS 2494, BS 3790, ISO 4184	112	550	5100	28	60	88	Lp
XPC	22	18	38	IS 2494, BS 3790, ISO 4184	180	600	5100	30	83	113	Lp

NARROW SECTION

Section	Top Width (in)	Thickness (in)	Angle (Degree)	Reference Standard	Minimum Pulley Dia. (in)	Mfg. Range (in)		Belt Length Factor (in)			Length Design
						Min.	Max.	Lp to La	Li to Lp	Li to La	
3VX	3/8"	5/16"	38	RMA IP 22	2 13/64"	23 1/2"	200"	33/64"	1 29/64"	1 31/32"	La
5VX	5/8"	35/64"	38	RMA IP 22	4 13/32"	23 1/2"	200"	63/64"	2 3/8"	3 11/32"	La
8VX	1"	29/32"	38	RMA IP 22	10"	90"	200"	2 3/32"	3 5/8"	5 23/32"	La

FEATURES:

- Conforms to: II 2GD c IIB X (Test report no. IB-03-4-934) – ATEX
- Ensures high level of protection against fire hazards
- Fire resistance properties complies per IS 2494 Part-II standard
- Anti-static values found 10 to 15 times lower than the maximum specified value, as per ISO 1813
- All FRAS Belts are certified by ATEX
- Resistance to emit inflammable substances while in operation
- Damage free and crack resistance properties to ensure smooth operation
- Longer service life
- Dimensional stability
- Anti-static, oil and heat resistant
- Temperature Range -31°F to 212°F (-35°C to 100°C)

APPLICATIONS:

Coal mines, fire-prone areas, petrochemical installations



X'TRA® -XV VARIABLE SPEED COGGED BELTS

Section	Top Width (in)	Thickness (in)	Angle (Degree)	Reference Standard	Pitch Length (in)		Belt Length Factor (in)		
					Min.	Max.	Lp to La	Li to Lp	Li to La
22V-A22/1422V	7/8"	5/16"	22	RMA IP 25	21 1/2"	200"	19/32"	1 3/8"	1 31/32"
30V-A22/1922V	1 1/8"	3/8"	22	RMA IP 25	21 1/2"	200"	25/32"	1 21/32"	2 7/16"
37V-A22/2322V	1 29/64"	7/16"	22	RMA IP 25	21 1/2"	200"	29/32"	1 13/16"	2 49/64"
30V-A26/1926V	1 1/8"	7/16"	26	RMA IP 25	21 1/2"	200"	29/32"	1 13/16"	2 49/64"
46V-A26/2926V	1 13/16"	1/2"	26	RMA IP 25	21 1/2"	200"	11/16"	2 7/32"	3 7/32"
51V-A26/3226V	2"	1/2"	26	RMA IP 25	21 1/2"	200"	11/16"	2 7/32"	3 7/32"
40V-A30/2530V	1 9/16"	19/32"	30	RMA IP 25	21 1/2"	200"	1 1/8"	2 1/4"	3 3/4"
51V-A30/3230V	2"	5/8"	30	RMA IP 25	21 1/2"	200"	1 19/64"	2 5/8"	3 15/16"
70V-A30/4430V	2 3/4"	11/16"	30	RMA IP 25	21 1/2"	200"	1 29/64"	3 1/32"	4 1/2"
64V-A36/4036V	2 1/2"	11/16"	36	RMA IP 25	21 1/2"	200"	1 29/64"	3 1/32"	4 1/2"
70V-A36/4436V	2 3/4"	11/16"	36	RMA IP 25	21 1/2"	200"	1 29/64"	3 1/32"	4 1/2"
76V-A36/4836V	3"	3/4"	36	RMA IP 25	21 1/2"	200"	1 1/2"	3 3/16"	4 23/32"

X'TRA® -XV VARIABLE SPEED COGGED BELTS

Section	Top Width (in)	Thickness (in)	Angle (Degree)	Reference Standard	Pitch Length (in)		Belt Length Factor (in)		
					Min.	Max.	Lp to La	Li to Lp	Li to La
HG	21/32"	5/16"	26	ISO 3410, ASAE S211-4	21 1/2"	200"	19/32"	1 3/8"	1 31/32"
HH	13/16"	25/64"	26	ISO 3410, ASAE S211-4	21 1/2"	200"	25/32"	1 21/32"	2 7/16"
HI	1"	1/2"	26	ISO 3410, ASAE S211-4	21 1/2"	200"	11/16"	2 5/32"	3 1/4"
HJ	1 1/4"	19/32"	26	ISO 3410, ASAE S211-4	21 1/2"	200"	13/16"	2 9/16"	3 3/4"
HK	1 1/2"	11/16"	26	ISO 3410, ASAE S211-4	21 1/2"	200"	1 29/64"	3 1/32"	4 1/2"
HL	1 3/4"	25/32"	26	ISO 3410, ASAE S211-4	21 1/2"	200"	1 9/16"	3 1/4"	4 13/16"
HM	2"	7/8"	26	ISO 3410, ASAE S211-4	21 1/2"	200"	1 3/4"	3 9/16"	5 5/16"
HN	2 1/4"	15/16"	26	ISO 3410, ASAE S211-4	21 1/2"	200"	1 31/32"	3 15/16"	5 29/32"
HO	2 1/2"	1"	26	ISO 3410, ASAE S211-4	21 1/2"	200"	2 5/64"	4 3/16"	6 1/4"

FEATURES:

- Excellent transverse rigidity and flexibility to prevent buckling at minimum diameter settings where belt stress is more
- Firm-gripping-action in the contact areas provide positive traction for precise and immediate response
- Higher power transmission capacity than regular belts
- Longer service-life
- Facilitates smooth running without excessive vibrations
- Specific belt-design for maximum longitudinal flexibility
- Extended Temperature Range -13°F to 212°F (-25°C to 100°C)



APPLICATIONS:

Variable speed pulley drives requiring exact speed control and maximum range of speed changes. They are suitable for recreational equipment, agricultural applications and machine tools.

NOTE:

Raw Edge Plain & Laminated Belts can be made on request. Intermediate sizes are available upon request.



PIX® VARIABLE SPEED COGGED BELTS

HARVESTER[®]-XV AGRICULTURAL COGGED BELTS

Section	Top Width (in)	Thickness (in)	Angle (Degree)	Reference Standard	Pitch Length (in)		Belt Length Factor (in)		
					Min.	Max.	Lp to La	Li to Lp	Li to La
22V-A22/1422V	7/8"	5/16"	22	RMA IP 25	21 1/2"	200"	19/32"	1 3/8"	1 31/32"
30V-A22/1922V	1 1/8"	3/8"	22	RMA IP 25	21 1/2"	200"	25/32"	1 21/32"	2 7/16"
37V-A22/2322V	1 29/64"	7/16"	22	RMA IP 25	21 1/2"	200"	29/32"	1 13/16"	2 49/64"
30V-A26/1926V	1 1/8"	7/16"	26	RMA IP 25	21 1/2"	200"	29/32"	1 13/16"	2 49/64"
46V-A26/2926V	1 13/16"	1/2"	26	RMA IP 25	21 1/2"	200"	11/16"	2 7/32"	3 7/32"
51V-A26/3226V	2"	1/2"	26	RMA IP 25	21 1/2"	200"	11/16"	2 7/32"	3 7/32"
40V-A30/2530V	1 9/16"	19/32"	30	RMA IP 25	21 1/2"	200"	11/8"	2 1/4"	3 3/4"
51V-A30/3230V	2"	5/8"	30	RMA IP 25	21 1/2"	200"	119/64"	2 5/8"	3 15/16"
70V-A30/4430V	2 3/4"	11/16"	30	RMA IP 25	21 1/2"	200"	1 29/64"	3 1/32"	4 1/2"
64V-A36/4036V	2 1/2"	11/16"	36	RMA IP 25	21 1/2"	200"	1 29/64"	3 1/32"	4 1/2"
70V-A36/4436V	2 3/4"	11/16"	36	RMA IP 25	21 1/2"	200"	1 29/64"	3 1/32"	4 1/2"
76V-A36/4836V	3"	3/4"	36	RMA IP 25	21 1/2"	200"	1 1/2"	3 3/16"	4 23/32"

HARVESTER[®]-XV AGRICULTURAL COGGED BELTS

Section	Top Width (in)	Thickness (in)	Angle (Degree)	Reference Standard	Pitch Length (in)		Belt Length Factor (in)		
					Min.	Max.	Lp to La	Li to Lp	Li to La
HG	21/32"	5/16"	26	ISO 3410, ASAE S211-4	21 1/2"	200"	19/32"	1 3/8"	1 31/32"
HH	13/16"	25/64"	26	ISO 3410, ASAE S211-4	21 1/2"	200"	25/32"	1 21/32"	2 7/16"
HI	1"	1/2"	26	ISO 3410, ASAE S211-4	21 1/2"	200"	11/16"	2 5/32"	3 1/4"
HJ	1 1/4"	19/32"	26	ISO 3410, ASAE S211-4	21 1/2"	200"	13/16"	2 9/16"	3 3/4"
HK	1 1/2"	11/16"	26	ISO 3410, ASAE S211-4	21 1/2"	200"	1 29/64"	3 1/32"	4 1/2"
HL	1 3/4"	25/32"	26	ISO 3410, ASAE S211-4	21 1/2"	200"	19/16"	3 1/4"	4 13/16"
HM	2"	7/8"	26	ISO 3410, ASAE S211-4	21 1/2"	200"	1 3/4"	3 9/16"	5 5/16"
HN	2 1/4"	15/16"	26	ISO 3410, ASAE S211-4	21 1/2"	200"	1 31/32"	3 15/16"	5 29/32"
HO	2 1/2"	1"	26	ISO 3410, ASAE S211-4	21 1/2"	200"	2 5/64"	4 3/16"	6 1/4"

FEATURES:

- Excellent transverse rigidity and flexibility to prevent buckling at minimum diameter settings where belt stress is more
- Firm-gripping-action in the contact areas provide positive traction for precise, immediate response
- Specially designed for applications with outside idlers
- More flexible, suitable for small pulley diameters
- Higher power transmission than regular belts
- Longer service-life
- Facilitates smooth running without excessive vibrations
- Specific belt-design for maximum longitudinal flexibility
- Extended Temperature Range -13°F to 212°F (-25°C to 100°C)

APPLICATIONS:

Variable speed pulley drives requiring exact speed control and maximum range of speed changes. They are suitable for recreational equipment, agricultural applications and machine tools.

POWERTEX[®]-XV2 TEXTILE MACHINERY COGGED BELTS

Section	Top Width (in)	Thickness (in)	Angle (Degree)	Reference Standard	Pitch Length (in)	Length Design
X62x221-K-1745	2 1/2"	7/8"	30	ISO 3410, ASAE S211-4	68.7"	Li
X70x221-K-1700	2 3/4"	7/8"	30	ISO 3410, ASAE S211-4	67"	Li
X70x221-K-1800	2 3/4"	7/8"	30	ISO 3410, ASAE S211-4	71"	La
X70x301-K-1810	2 3/4"	1 1/8"	30	ISO 3410, ASAE S211-4	71"	La

FEATURES:

- Designed for spinning mills to operate the spindles at up to 20000 rpm
- Designed to meet high power transmission requirement observed in textile mills, up to 60 kW
- Higher power transmission capacity
- Excellent performance and customer satisfaction by offering energy saving
- PIX PowerTex[®] Variable speed belts are used in applications involving varying speed controls. The special belt structure offers smooth performance at high dynamic loads, superior power transmission capability, good speed control characteristics and an augmented belt life
- Extended Temperature Range -13°F to 212°F (-25°C to 100°C)

APPLICATIONS:

Spinning Mills in textile industry

NOTE:

Other sizes are available upon request.

SPECTRA® -XR RAW EDGE LAMINATED BELTS

Section	Top Width (in)	Thickness (in)	Angle (Degree)	Reference Standard	Minimum Pulley Dia. (in)	Mfg. Range (in)		Belt Length Factor (in)			Length Design
						Min.	Max.	Lp to La	Li to Lp	Li to La	
A	1/2"	5/16"	36	IS 2494, BS 3790, ISO 4184	2 1/2"	24"	118"	35/64"	1 27/64"	1 31/32"	Li
B	21/32"	7/16"	36	IS 2494, BS 3790, ISO 4184	3 1/2"	24"	195"	1 1/32"	1 45/64"	2 23/32"	Li
C	7/8"	35/64"	36	IS 2494, BS 3790, ISO 4184	5 1/2"	51"	195"	1 1/4"	2 13/64"	3 15/32"	Li

FEATURES:

- Center placed polyester cords
- Better heat dissipation
- Superior belt life
- Enhanced strength
- Increased productivity & efficiency
- Improved flexibility
- Oil Resistant & Anti-static
- Temperature Range: -0°F to 176°F (-18°C to 80°C)



X'TRA® -XP RAW EDGE PLAIN BELTS X'TRA® -XL RAW EDGE LAMINATED BELTS

CLASSICAL SECTION

Section	Top Width (in)	Thickness (in)	Angle (Degree)	Reference Standard	Minimum Pulley Dia. (in)	Mfg. Range (in)		Belt Length Factor (in)			Length Design
						Min.	Max.	Lp to La	Li to Lp	Li to La	
ZX	25/64"	15/64"	36	IS 2494, BS 3790, ISO 4184	1 37/64"	21 1/2"	200"	5/8"	7/8"	1 1/2"	Li
AX	1/2"	5/16"	36	IS 2494, BS 3790, ISO 4184	2 1/2"	21 1/2"	200"	35/64"	1 27/64"	1 31/32"	Li
BX	21/32"	7/16"	36	IS 2494, BS 3790, ISO 4184	3 1/2"	21 1/2"	200"	1 1/32"	1 45/64"	2 23/32"	Li
CX	7/8"	35/64"	36	IS 2494, BS 3790, ISO 4184	5 1/2"	23 1/2"	200"	1 1/4"	2 13/64"	3 15/32"	Li
DX	1 1/4"	3/4"	36	IS 2494, BS 3790, ISO 4184	11"	23 1/2"	200"	1 37/64"	3 7/64"	4 11/16"	Li

LIGHT DUTY SINGLE V-BELTS

Section	Top Width (in)	Thickness (in)	Angle (Degree)	Reference Standard	Minimum Pulley Dia. (in)	Mfg. Range (in)		Belt Length Factor (in)			Length Design
						Min.	Max.	Lp to La	Li to Lp	Li to La	
2LX	1/4"	5/32"	36	RMA IP 23	1"	21 1/2"	200"	NA	NA	NA	La
3LX	3/8"	1/4"	36	RMA IP 23	1 27/64"	21 1/2"	200"	5/8"	7/8"	1 1/2"	La
4LX	1/2"	5/16"	36	RMA IP 23	2 9/32"	21 1/2"	200"	9/16"	1 27/64"	1 31/32"	La
5LX	5/8"	3/8"	36	RMA IP 23	2 53/64"	21 1/2"	200"	1 1/32"	1 45/64"	2 23/32"	La

FEATURES:

- Oil Resistant & Anti-static
- Max. belt linear speed
 - Classical 98 ft / sec
 - Wedge 137 ft / sec
 - Narrow 147 ft / sec
 - Light Duty 90 ft / sec
- Higher power transmission capacity than wrapped belts
- Superior transverse stiffness & high wear resistance
- Temperature Range 0°F to 176°F (-18°C to 80°C)
- ATEX certified FRAS Belts also available (see page 9)

APPLICATION:

Golf-carts, snowmobiles, mini-bikes, material handling & industrial equipment.

NOTE:

Intermediate sizes are available upon request.



ASYMMETRA® ASYMMETRIC BELTS

Top Width (in)	Thickness (in)	Angle (Degree)	Angle (Degree)	Mfg. Range (in)		Length Design
				Min.	Max.	
5/8"	25/64"	18	2	26 3/4"	88 3/16"	La
3/4"	25/64"	18	2	26 3/4"	88 3/16"	La

APPLICATION:

Golf-carts, snowmobiles, mini-bikes, material handling & industrial equipment.



FEATURES:

- Torque converter systems
- High lateral rigidity
- Longer life
- Excellent shock absorbing capacity
- Temperature Range: -13°F to 212°F (-25°C to 100°C)

X'ACT[®] TIMING / SYNCHRONOUS BELTS

CLASSICAL SECTION

Section	Pitch (in)	Tooth Height (in)	Belt Thickness (in)	Reference Standard	Mfg. Range (in)		Length Design
					Min.	Max.	
MXL	5/64"	1/32"	3/64"	BS 4548, IS 5294, IS 5296	53/64"	69 23/32"	Lp
XXL	1/8"	1/32"	1/16"	BS 4548, IS 5294, IS 5296	1 13/32"	8 5/8"	Lp
XL	13/64"	1/16"	3/32"	BS 4548, IS 5294, IS 5296	1 47/64"	83 25/32"	Lp
L	3/8"	5/64"	9/64"	BS 4548, IS 5294, IS 5296	2 5/8"	106 5/16"	Lp
H	1/2"	3/32"	11/64"	BS 4548, IS 5294, IS 5296	5 45/64"	107 7/64"	Lp
XH	7/8"	1/4"	7/16"	BS 4548, IS 5294, IS 5296	18 1/4"	89 37/64"	Lp
XXH	1 1/4"	3/8"	5/8"	BS 4548, IS 5294, IS 5296	24 5/8"	78 3/4"	Lp

Belt label description:

CLASSICAL 270 XL 025		
270	XL	025
Pitch Length	Section Tooth Pitch	Belt Width
27"	13/64"	0.25"
Maximum sleeve widths are available up to 17 23/32"		

STD SECTION

Section	Pitch (mm)	Tooth Height (mm)	Belt Thickness (mm)	Reference Standard	Mfg. Range (mm)		Length Design
					Min.	Max.	
S 2M	2	0.76	1.36	ISO 13050	60	3700	Lp
S 3M	3	1.14	2.20	ISO 13050	120	6510	Lp
S 4.5M	4.5	1.83	2.90	ISO 13050	120	6510	LP
S 5M	5	1.91	3.40	ISO 13050	150	4000	Lp
S 8M	8	3.05	5.30	ISO 13050	376	6640	Lp
S 14M	14	5.3	10.20	ISO 13050	714	5012	Lp

Belt label description:

STD 150 S5M 650		
150	S5M	650
Belt Width	Section Tooth Pitch	Pitch Length
15 mm	5 mm	650 mm
Maximum sleeve widths are available up to 460 mm		

HTD SECTION

Section	Pitch (mm)	Tooth Height (mm)	Belt Thickness (mm)	Reference Standard	Mfg. Range (mm)		Length Design
					Min.	Max.	
2M	2	0.75	1.36	ISO 13050	52	750	Lp
3M	3	1.17	2.40	ISO 13050	60	6804	Lp
5M	5	2.06	3.80	ISO 13050	180	3750	Lp
8M	8	3.48	6	ISO 13050	184	6880	Lp
14M	14	6.02	10	ISO 13050	812	8120	Lp

Belt label description:

HTD 800 8M 30		
800	8M	30
Pitch Length	Section Tooth Pitch	Belt Width
800 mm	8 mm	30 mm
Maximum sleeve widths are available up to 450 mm		

FEATURES:

- High efficiency due to positive engagement between belt teeth and pulley grooves
- Maintenance-free, no re-tensioning & high tension required
- Fiberglass cord provides strength, excellent flex life & high resistance to elongation
- Exact power transmission
- Low noise level & longer service life
- Improved stress distribution
- Temperature Range -13°F to 212°F (-25°C to 100°C)

APPLICATION:

Suitable for drives demanding exact power transmission such as robotic machines, textile machinery, CNC machines, electronic equipment such as printers, scanners, currency counting machines.

NOTE:

These sizes are indicative & denotes minimum & maximum range. For intermediate sizes please contact us.



CLASSICAL SECTION

Section	Pitch (in)	Tooth Height (in)	Belt Thickness (in)	Reference Standard	Width (in)		Length (ft)		Length Design
					Min.	Max.	Min.	Max.	
MXL	5/64"	1/32"	3/64"	BS 4548, IS 5294, IS 5296	1/8"	25/32"	25'	328'	Lp
XL	13/64"	1/16"	3/32"	BS 4548, IS 5294, IS 5296	13/32"	25/32"	25'	328'	Lp
L	3/8"	5/64"	9/64"	BS 4548, IS 5294, IS 5296	23/64"	7"	25'	328'	Lp
H	1/2"	3/32"	11/64"	BS 4548, IS 5294, IS 5296	15/32"	7"	25'	118'	Lp

STD SECTION

Section	Pitch (mm)	Tooth Height (mm)	Belt Thickness (mm)	Reference Standard	Width (mm)		Length (ft)		Length Design
					Min.	Max.	Min.	Max.	
S 3M	3	1.14	2.20	ISO 13050	5	25	25'	328'	Lp
S 5M	5	1.91	3.40	ISO 13050	6	25	25'	328'	Lp
S 8M	8	3.05	5.30	ISO 13050	9	25	25'	328'	Lp
S 14M	14	5.3	10.20	ISO 13050	40	180	25'	118'	Lp

HTD SECTION

Section	Pitch (mm)	Tooth Height (mm)	Belt Thickness (mm)	Reference Standard	Width (mm)		Length (ft)		Length Design
					Min.	Max.	Min.	Max.	
3M	3	1.17	2.40	ISO 13050	5	25	25'	328'	Lp
5M	5	2.06	3.80	ISO 13050	6	25	25'	328'	Lp
8M	8	3.48	6	ISO 13050	9	25	25'	328'	Lp
14M	14	6.02	10	ISO 13050	40	180	25'	118'	Lp

FEATURES:

- High efficiency due to positive engagement between belt teeth and pulley grooves
- Fiberglass cord provides strength, excellent flex life & high resistance to elongation
- Exact power transmission
- Longer service life
- Improved stress distribution
- Temperature Range -13°F to 212°F (-25°C to 100°C)

APPLICATION:

Fitness machines, printers, sliding doors, garage automatic doors, level controls on elevators, airport baggage handling systems, electronic assembly lines.

NOTE:

The minimum order length is 25' or 300". For custom widths & lengths please contact us.

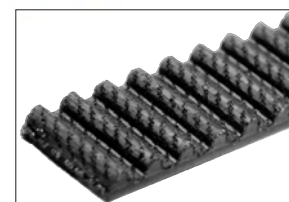

TORQUEPLUS[®]-XT2 HIGH POWER TIMING BELTS

STD SECTION

Section	Pitch (mm)	Tooth Height (mm)	Belt Thickness (mm)	Reference Standard	Mfg. Range (mm)		Length Design
					Min.	Max.	
S5M	5	1.91	3.40	ISO 13050	350	2525	Lp
S8M	8	3.05	5.30	ISO 13050	376	2848	Lp

HTD SECTION

Section	Pitch (mm)	Tooth Height (mm)	Belt Thickness (mm)	Reference Standard	Mfg. Range (mm)		Length Design
					Min.	Max.	
5M	5	2.06	3.80	ISO 13050	300	2250	Lp
8M	8	3.48	6	ISO 13050	344	4400	Lp
14M	14	6.02	10	ISO 13050	966	4578	Lp

FEATURES:

- 50% to 70% enhancement in power-rating over PIX-X'act[®] HTD/STD Belts
- Quiet performance
- Higher operational speed, resistance to loads and low noise
- No lubrication and re-tensioning required, resulting in lower maintenance and labor cost
- Increased operational efficiency up to 98%
- Compact, lower operational cost.
- Anti-static properties as required by ISO 9563
- Temperature Range -13°F to 212°F (-25°C to 100°C)

APPLICATION:

Food processing, packaging, paper machines, printing machines, robotic equipment, conveyors, office equipment, medical equipment.



Belt label description:

STD 150 S5MXT 650

150	S5MXT	650
Belt Width	Section Tooth Pitch	Pitch Length
15 mm	5 mm	650 mm

Maximum sleeve widths are available up to 460 mm

Belt label description:

HTD 800 8MXT 30

800	8MXT	30
Pitch Length	Section Tooth Pitch	Belt Width
800 mm	8 mm	30 mm

Maximum sleeve widths are available up to 460 mm

DUO[®]-XT DOUBLE SIDED TIMING BELTS

CLASSICAL SECTION

Section	Pitch (in)	Tooth Height (in)	Belt Thickness (in)	Reference Standard	Mfg. Range (in)		Length Design
					Min.	Max.	
DA-XL	13/64"	1/16"	3/32"	BS 4548, IS 5296	7 7/8"	22 27/32"	Lp
DA-L	3/8"	5/64"	9/64"	BS 4548, IS 5296	7 3/8"	26"	Lp
DA-H	1/2"	3/32"	11/64"	BS 4548, IS 5296	7 7/8"	107 1/8"	Lp

Belt label description:

CLASSICAL 270 XL 025

270	XL	025
Pitch Length	Section Tooth Pitch	Belt Width
27"	13/64"	0.25"

Maximum sleeve widths are available up to 7 7/8"

STD SECTION

Section	Pitch (mm)	Tooth Height (mm)	Belt Thickness (mm)	Reference Standard	Mfg. Range (mm)		Length Design
					Min.	Max.	
DA-S5M	5	1.91	3.40	ISO 13050	410	1420	Lp
DA-S8M	8	3.05	5.30	ISO 13050	512	6640	Lp

Belt label description:

STD 150 S5M 650

150	S5M	650
Belt Width	Section Tooth Pitch	Pitch Length
15 mm	5 mm	650 mm

Maximum sleeve widths are available up to 200 mm

HTD SECTION

Section	Pitch (mm)	Tooth Height (mm)	Belt Thickness (mm)	Reference Standard	Mfg. Range (mm)		Length Design
					Min.	Max.	
DA-3M	3	1.17	2.40	ISO 13050	501	1401	Lp
DA-5M	5	2.06	3.80	ISO 13050	400	2050	Lp
DA-8M	8	3.48	6	ISO 13050	512	4400	Lp
DA-14M	14	6.02	10	ISO 13050	1400	6860	Lp

Belt label description:

HTD 800 8M 30

800	8M	30
Pitch Length	Section Tooth Pitch	Belt Width
800 mm	8 mm	30 mm

Maximum sleeve widths are available up to 180 mm

FEATURES:

- Power transmission from both sides
- Highly flexible
- Free from maintenance
- Extended stability, durability, strength and life
- Temperature Range -13°F to 176°F (-25°C to 80°C)

APPLICATION:

For serpentine drives like in textile, paper packaging & printing industries, hand-held power tools, postage handling, food processing, office equipment, ticket dispensers, robotics, vending machines and vacuum cleaners.

NOTE:

These sizes are indicative & denotes minimum & maximum range. For intermediate sizes please contact us.

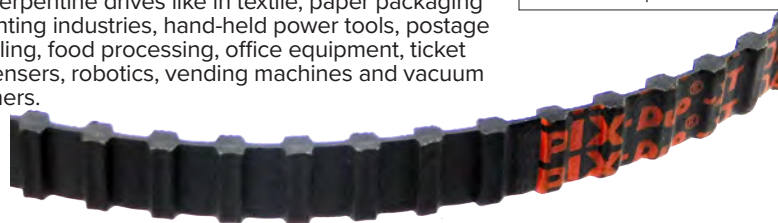

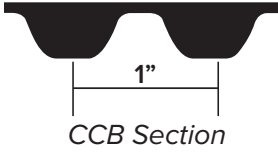

TORQUEPLUS® -XT2 COTTON CLEANER

Section	Pitch (in)	Tooth Height (in)	Belt Thickness (in)	Reference Standard	Mfg. Range (in)		Length Design
					Min.	Max.	
CCB	1"	15/64	29/64"	PIX Proprietary	61"	65"	Lp

PIX TORQUEPLUS-XT2 Cotton Cleaner Synchronous Belts are custom designed to be an exact OEM replacement for cotton gin drives.

Cotton Cleaner Belt Construction:

- Specially compounded teeth are made of a special compound, reinforced with special fibers and elastomer which transmit high tooth strength & extreme level of fatigue.
- Kevlar® cord for increased shock and high tensile strength
- Special Poly-Amide fabric which is extremely resistant to abrasion and offers a low coefficient of friction

FEATURES:

- High tensile Kevlar® cords to sustain severe shock loads
- Excellent fatigue resistant compound
- Extended service life
- Maintenance-free
- Oil, Heat and Ozone resistant

APPLICATION:

Cotton Gins & Inclined Cleaner Machines



BRAWN® -XT HYBRID POLY+TIMING BELTS

Section	Pitch (mm)	Tooth Height (mm)	Belt Thickness (mm)	Profile	# of Ribs	Rib Pitch (mm)	Reference Standard	Mfg. Range (mm)		Length Design
								Min.	Max.	
8M	8	3.48	6	PK	6 to 126	3.56	ISO 13050, RMA/MPTA IP-26	1200	4400	Lp
14M	14	6.02	10	PL	6 to 88	4.7	ISO 13050, RMA/MPTA IP-26	1260	4578	Lp
S8M	8	3.05	5.30	PK	6 to 126	3.56	ISO 13050, RMA/MPTA IP-26	1200	2848	Lp

FEATURES:

- Combines the advantages of Synchronous and Poly V-Belts
- Transverse teeth for positive engagement on one side and longitudinal ribs for non-synchronous frictional transmission on the other side.
- Suitable for multi-shaft transmission with reversed rotary directions of pulleys
- Made with EPDM rubber for greater flexibility
- Anti-static, oil and heat resistant
- Noise-free transmission
- Temperature Range -31°F to 266°F (-35°C to 130°C)

APPLICATION:

Flour & rice mills, food-grain industries

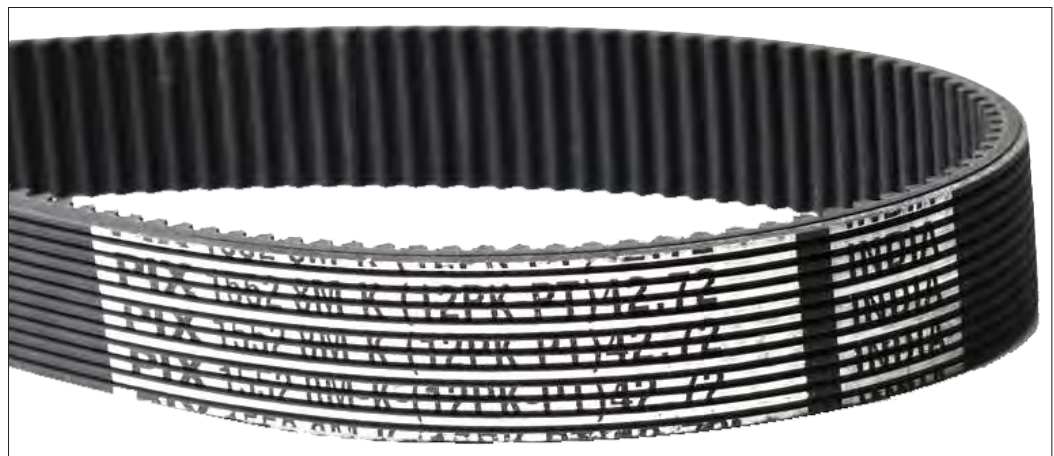

DuPont™ and Kevlar® are trademarks or registered trademarks of E.I. du Pont de Nemours and Company.

SPECIALITY TIMING BELTS

TOPCOAT®-XT PACKAGING MACHINERY

TOP COAT

Section	Pitch (in)	Tooth Height (in)	Top Coat Thickness that are available (in)	Top Width (in)		Mfg. Length Range (in)		Length Design
				Min.	Max.	Min.	Max.	
L	3/8"	5/64"	5/32", 1/4" & 5/16"	45/64"	17 3/4"	20 7/8"	78 3/4"	Lp
H	1/2"	3/32"	5/32", 1/4" & 5/16"	45/64"	17 3/4"	20 7/8"	78 3/4"	Lp

STEP-CUT

Section	Pitch (in)	Tooth Height (in)	Top Coat Thickness that are available (in)	Top Width (in)		Mfg. Length Range (in)		Length Design
				Min.	Max.	Min.	Max.	
L	3/8"	5/64"	5/16" & 3/8"	1"	111/32"	22 7/16"	78 3/4"	Lp
H	1/2"	3/32"	5/16" & 3/8"	13/8"	2 3/8"	53 5/32"	78 3/4"	Lp

FEATURES:

- Profile top rubber provides excellent cushioning coupled with extra elasticity
- Provides optimum friction suitable for proper support to contact material
- Belts are designed with abrasion resistant properties
- Excellent service life
- Step-cut belts are available for smaller pulley diameters, providing extra flexibility
- Temperature Range 0°F to 176°F (-18°C to 80°C)

NOTE:

1. Belt selection should strictly be done on the basis of temperature, top coat hardness & application.
2. Availability of a particular size in product range to be cross checked before placing the order.
3. 5M, 8M, S5M & S8M Belt sections are available upon request. Please contact us for more information.



APPLICATION:

Office automation equipment, vending machines, machine tools and pumps, textile machines, paper manufacturing machines, printing machinery, medical equipment, optical instruments, food processing equipment, packaging machinery, robotics and plotters.



XPEDIENT®-XT POLYURETHANE TIMING BELTS

CLASSICAL SECTION

Section	Pitch (in)	Tooth Height (in)	Belt Thickness (in)	Reference Standard	Mfg. Range (in)		Length Design
					Min.	Max.	
MXL	5/64"	1/32"	3/64"	ISO 5296, BS 4548	5 3/4"	46 1/2"	Lp
XL	13/64"	1/16"	3/32"	ISO 5296, BS 4548	6"	75"	Lp
L	3/8"	5/64"	9/64"	ISO 5296, BS 4548	12 13/32"	72 13/16"	Lp
H	1/2"	3/32"	11/64"	ISO 5296, BS 4548	23"	110"	Lp

METRIC SECTION

Section	Pitch (mm)	Tooth Height (mm)	Belt Thickness (mm)	Reference Standard	Mfg. Range (mm)		Length Design
					Min.	Max.	
AT5	5	1.20	2.70	ISO 17396, DIN 7721	225	2000	Lp
AT10	10	2.50	4.50	ISO 17396, DIN 7721	250	2350	Lp
T2.5	2.5	.07	1.3	ISO 17396, DIN 7721	145	1750	Lp
T5	5	1.20	2.20	ISO 17396, DIN 7721	120	1955	LP
T10	10	2.50	4.50	ISO 17396, DIN 7721	250	3330	Lp

STD SECTION

Section	Pitch (mm)	Tooth Height (mm)	Belt Thickness (mm)	Reference Standard	Mfg. Range (mm)		Length Design
					Min.	Max.	
S3M	3	1.14	2.20	ISO 13050	177	660	Lp
S5M	5	1.91	3.40	ISO 13050	320	635	Lp

HTD SECTION

Section	Pitch (mm)	Tooth Height (mm)	Belt Thickness (mm)	Reference Standard	Mfg. Range (mm)		Length Design
					Min.	Max.	
3M	3	1.21	2.40	ISO 13050	168	963	Lp
5M	5	2.08	3.8	ISO 13050	250	2500	Lp
8M	8	3.38	6	ISO 13050	560	1760	Lp

FEATURES:

- Polyurethane timing belts are highly flexible with longitudinal toughness to ensure perfect tooth meshing
- No dust-generation or flaking while running - clean belt
- Homogeneous throughout its cross-section by virtue of Thermoset molding process
- Superior wear and abrasion resistance
- High resistance to oil, fat and grease
- Excellent resistance to aging, hydrolysis, UV and ozone
- Low vibration and reduced noise level
- Good resistance to most acids and alkalies
- Temperature Range -22°F to 176°F (-30°C to 80°C)

APPLICATION:

Office automation equipment, vending machines, machine tools and pumps, textile machines, paper manufacturing machines, printing machinery, medical equipment, optical instruments, food processing equipment, packaging machinery, robotics and plotters.

NOTE:

These sizes are indicative & denote minimum & maximum range. For intermediate sizes please contact us.

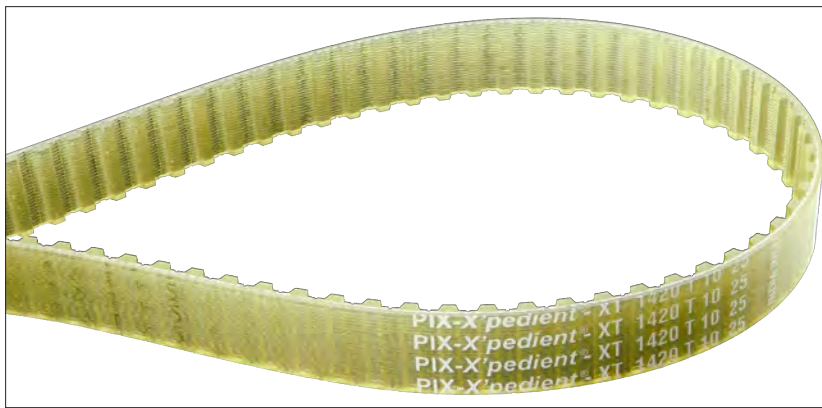
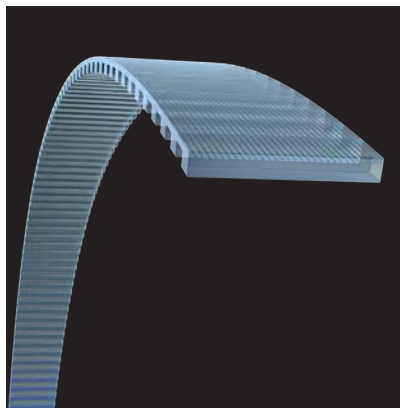

XPEDIENT®-XT POLYURETHANE DOUBLE SIDED TIMING BELTS

CLASSICAL SECTION

Section	Pitch (in)	Tooth Height (in)	Belt Thickness (in)	Reference Standard	Mfg. Range (in)		Length Design
					Min.	Max.	
DA-MXL	5/64"	1/32"	1/16"	ISO 5296	9 5/8"	40"	Lp
DA-XL	13/64"	1/16"	1/8"	ISO 5296	15"	26"	Lp
DA-L	3/8"	5/64"	3/16"	ISO 5296	TBD	52 1/2"	Lp

METRIC SECTION

Section	Pitch (mm)	Tooth Height (mm)	Belt Thickness (mm)	Reference Standard	Mfg. Range (mm)		Length Design
					Min.	Max.	
DT5	5	1.20	3.25	ISO 17396, DIN 7721	260	1700	LP
DT10	10	2.50	6.80	ISO 17396, DIN 7721	260	2500	Lp

HTD SECTION

Section	Pitch mm	Tooth Height mm	Belt Thickness mm	Reference Standard	Mfg. Range (mm)		Length Design
					Min.	Max.	
3M	3	1.21	3.20	ISO 13050	252	636	Lp
5M	5	2.08	5.3	ISO 13050	615	1110	Lp
8M	8	3.38	8.10	ISO 13050	TBD	1680	LP

FEATURES:

- Polyurethane timing belts are highly flexible with longitudinal toughness to ensure perfect tooth meshing
- No dust-generation or flaking while running - clean belt
- Homogeneous throughout its cross-section by virtue of Thermoset molding process
- Superior wear and abrasion resistance
- High resistance to oil, fat and grease
- Excellent resistance to aging, hydrolysis, UV and ozone
- Low vibration and reduced noise level
- Good resistance to most acids and alkalies
- Temperature Range -22°F to 176°F (-30°C to 80°C)

APPLICATION:

Office automation equipment, vending machines, machine tools and pumps, textile machines, paper manufacturing machines, printing machinery, medical equipment, optical instruments, food processing equipment, packaging machinery, robotics and plotters.

NOTE:

These sizes are indicative & denote minimum & maximum range. For intermediate sizes please contact us.



X'CEED® RIBBED / POLY V-BELTS

Section	Thickness (in)	Rib Pitch (in)	# of Ribs Possible	Reference Standard	Minimum Pulley Dia. (in)	Mfg. Range (in)		Length Design
						Min.	Max.	
PH	1/8"	1/16"	2 to 280	RMA IP-26, ISO 9981	1/2"	11"	200"	Le
PJ	5/32"	3/32"	2 to 240	RMA IP-26, ISO 9981	51/64"	11"	200"	Le
PK	3/16"	9/64"	2 to 150	RMA IP-26, ISO 9981	1 13/32"	11"	200"	Le
PL	5/16"	3/16"	2 to 110	RMA IP-26, ISO 9981	2 15/16"	19 11/16"	394"	Le
PM	1/2"	3/8"	2 to 52	RMA IP-26, ISO 9981	7 3/32"	37 13/32"	394"	Le

FEATURES:

- Oil resistant & anti-static
- High power transmission capacity
- Maximum belt linear speed up to 164 ft/sec
- Highly flexible, noise free & smooth running
- Can be used for speed ratios up to 1:30
- Temperature Range -13°F to 212°F (-25°C to 100°C)



APPLICATION:

Compact drives with high speed ratios, drives requiring minimum maintenance, drives in a noise sensitive environment, for serpentine drives and drives with reverse bend idlers like household appliances, work tools, machine tools.

FRAS® -XC FIRE RESISTANT ANTI-STATIC RIBBED / POLY V-BELTS

Section	Thickness (in)	Rib Pitch (in)	# of Ribs Possible	Reference Standard	Minimum Pulley Dia. (in)	Mfg. Range (in)		Length Design
						Min.	Max.	
PJ	5/32"	3/32"	2 to 240	RMA IP-26, ISO 9981	51/64"	11"	200"	Le
PK	3/16"	9/64"	2 to 150	RMA IP-26, ISO 9981	1 13/32"	11"	200"	Le
PL	5/16"	3/16"	2 to 110	RMA IP-26, ISO 9981	2 15/16"	19 11/16"	200"	Le
PM	1/2"	3/8"	2 to 52	RMA IP-26, ISO 9981	7 3/32"	37 13/32"	200"	Le

FEATURES:

- Conforms to: II 2GD c IIB X (Test report no. IB-03-4-934) - ATEX
- Ensures high level of protection against fire hazards
- ATEX values of electrical resistance are approximately 10-15 times more stringent than ISO 1813, leading to a safer drive
- Resistance to emit inflammable substances while in operation
- Damage free and crack resistance properties to ensure smooth operation
- Longer service life
- Dimensional stability
- Temperature Range -13°F to 212°F (-25°C to 100°C)

APPLICATION:

Coal mines, fire prone areas, petrochemical installations



THERMAL® -XC HIGH TEMPERATURE RIBBED / POLY V-BELTS

Section	Thickness (in)	Rib Pitch (in)	# of Ribs Possible	Reference Standard	Minimum Pulley Dia. (in)	Mfg. Range (in)		Length Design
						Min.	Max.	
PJ	5/32"	3/32"	2 to 240	RMA IP-26, ISO 9981	51/64"	11"	200"	Le
PK	3/16"	9/64"	2 to 150	RMA IP-26, ISO 9981	1 13/32"	11"	200"	Le
PL	5/16"	3/16"	2 to 110	RMA IP-26, ISO 9981	2 15/16"	19 11/16"	200"	Le

FEATURES

- High temperature resistant
- Longer service life
- Resistant to crack and damage, even at high temperature
- Higher power transmission capacity compared to regular belts
- Temperature Range -31°F to 266°F (-35°C to 130°C)

APPLICATION:

Automotive, material handling equipment, cooling systems



DUO[®]-XC DOUBLE SIDED RIBBED / POLY V-BELTS

Section	Thickness (in)	Rib Pitch (in)	# of Ribs Possible	Reference Standard	Minimum Pulley Dia. (in)	Mfg. Range (in)		Length Design
						Min.	Max.	
DPK	19/64"	9/64"	2 to 22	RMA IP-26, ISO 9981	1 31/32"	47 1/4"	128 9/64"	Lp
DPL	29/64"	3/16"	2 to 22	RMA IP-26, ISO 9981	2 15/16"	47 1/4"	128 9/64"	Lp

FEATURES:

- Extremely flexible, reduced bending stress, suitable for smaller diameter pulley
- Optimal performance even at high speeds
- Ensures noise-free operation
- Increased contact surface area
- Efficient power transmission
- Anti-static, oil and heat resistant
- Compact drives
- Used on the drive with pulleys rotating in both clockwise and anticlockwise directions
- Transmit the power from both the sides of the belt
- Temperature Range -13°F to 212°F (-25°C to 100°C)



APPLICATION:

High speed engines, serpentine drives, textile machines

POLYSTRETCH[®]-XC ELASTICATED RIBBED / POLY V-BELTS

Section	Thickness (in)	Rib Pitch (in)	# of Ribs	Reference Standard	Minimum Pulley Dia. (in)	Mfg. Range (in)		Length Design
						Min.	Max.	
EL-PJ	5/32"	3/32"	2 to 20	RMA IP-26, ISO 9981	3/4"	14"	88 3/16"	Le

FEATURES:

- Belt with elastic properties
- Temperature Range -13°F to 212°F (-25°C to 100°C)

APPLICATION:

Washing machine & dryers

TOPCOAT[®]-XC PACKAGING MACHINERY RIBBED / POLY V-BELTS

Section	Thickness (in)	Rib Pitch (in)	# of Ribs	Reference Standard	Minimum Pulley Dia. (in)	Mfg. Range (in)		Length Design
						Min.	Max.	
PJ	5/32"	3/32"	6 to 220	RMA IP-26, ISO 9981	3/4"	27 9/16"	67"	Le
PK	3/16"	9/64"	5 to 140	RMA IP-26, ISO 9981	1 31/32"	27 9/16"	67"	Le
PL	5/16"	3/16"	4 to 100	RMA IP-26, ISO 9981	2 15/16"	27 9/16"	67"	Le

FEATURES:

- Profile top rubber, specific to applications
- Facilitates excellent cushioning coupled with extra elasticity
- Excellent flexibility to prevent cracks or tearing
- Optimum friction suitable for providing proper support to the contact material
- Vulcanized as a single piece to ensure excellent adhesion
- Abrasion resistant
- Longer life
- Top profile thickness: 4mm, 6mm, 8mm & 10mm
- Temperature Range -0°F to 176°F (-18°C to 80°C)

NOTE:

1. Belt selection should strictly be done on the basis of temperature, top coat hardness & application.
2. Availability of a particular size in product range to be cross checked before placing the order.



APPLICATION:

FFS (Form-fill & seal) machine, bakery, paper & printing, soaps & cosmetics, cable-drawing, plastic tube drawing, bottling plants.

FORCE[®] AUTOMOTIVE RAW EDGE COGGED BELTS

Section	Top Width (mm)	Thickness (mm)	Angle (Degree)	Conforms to Standard	Mfg. Range (mm)		Length Design
					Min.	Max.	
X9.5 / AVX10	10	8	36	BS AU 150b, SAE J 636, JASO E 107	550	5100	La
X12.5 / AVX13	13	10	36	BS AU 150b, SAE J 636, JASO E 107	550	5100	La
X10A / 13	10.5	8	36	BS AU 150b, SAE J 636, JASO E 107	550	5100	Le
X11A / 15	11.5	8	36	BS AU 150b, SAE J 636, JASO E 107	550	5100	Le
X13A / 17	13.5	9	36	BS AU 150b, SAE J 636, JASO E 107	550	5100	Le
X15A / 22	17	10.5	36	BS AU 150b, SAE J 636, JASO E 107	550	5100	Le
X17A / 24	18.5	11	36	BS AU 150b, SAE J 636, JASO E 107	550	5100	Le
X20A / 28	21.5	12.5	36	BS AU 150b, SAE J 636, JASO E 107	550	5100	Le

FEATURES:

- Engineered and chemically treated modulus & low stretch tensile cords for higher loads without stretch
- Fiber reinforced rubber matrix base compound, for better grip and lateral rigidity
- Excellent resistant to oil and heat, suitable to operate on small pulley diameters
- Suitable for Heavy Earth Moving Machinery applications
- Temperature Range -13°F to 212°F (-25°C to 100°C)

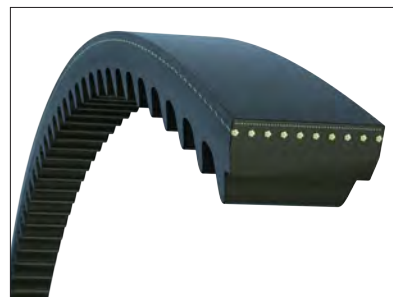

FORCE[®] AUTOMOTIVE RIBBED / POLY V-BELTS

Section	Thickness (in)	Rib Pitch (in)	Conforms to Standard	Minimum Pulley Dia. (in)	Mfg. Range (in)		Length Design
					Min.	Max.	
PK	3/16"	9/64"	ISO 9981, ISO 9982, RMA IP 26	1 31/32"	11"	200"	Le

FEATURES:

- Trapezoid faced ribs on a fiber reinforced rubber matrix for higher power transmission offering good resistance to wear and tear, facilitating quiet running
- Reduced vibrations, shock absorber, low stretch and an excellent behavior under heavy load conditions
- Extremely flexible, capable to work on small pulley diameters and serpentine drives
- Oil and heat resistant, longer service life
- Suitable for Heavy Earth Moving Machinery applications
- Temperature Range -31°F to 266°F (-35°C to 130°C)



FORCE[®] AUTOMOTIVE TIMING BELTS

Section	Pitch (mm)	Tooth Height (mm)	Belt Thickness (mm)	Conforms to Standard	Manufacturing Sizes Available (mm)
ZA	9.525	1.91	4.1	ISO 9010, JASO E 105	88, 104, 111
ZB	9.525	2.29	4.5	ISO 9010, JASO E 105	137
ZH	9.525	3.5	5.5	ISO 9010, JASO E 105	89, 97, 104, 109, 114, 129, 136, 138, 153
PR	9.525	3.45	5.5	ISO 9010, JASO E 105	136
PRM	9.525	3.37	5.5	ISO 9010, JASO E 105	97, 122, 123, 124, 134
PRP	9.525	3.5	5.5	ISO 9010, JASO E 105	177, 185
YU	8	3.02	5.2	ISO 9010, JASO E 105	101, 106, 107, 109, 115

FEATURES:

- Trapezoidal tooth design for sections ZA, ZB and curvilinear tooth design for other sections
- Precisely formed and accurately spaced teeth ensure smooth engagement with pulley grooves
- Fiberglass tensile cords provide strength, excellent flex life and high resistance to elongation
- Durable backing protects against environmental pollution and friction wear
- Tough nylon surface protects the tooth surface
- Temperature Range -13°F to 212°F (-25°C to 100°C)



NOTE:

Available in high temperature HSN construction also.

SPRINTPRO[®]-XC AUTOMOTIVE APPLICATION SPECIFIC BELTS

Section	Thickness (in)	Rib Pitch (in)	# of Ribs	Conforms to Standard	Minimum Pulley Dia. (in)	Mfg. Range (in)		Length Design
						Min.	Max.	
PK	3/16"	9/64"	2 to 140	ISO 9010, JASO E 105	1 31/32"	23 5/8"	197"	Le

PIX-SprintPro[®]-XC, Poly-V Belts are specially designed for high speed & high horse-power applications. The Aramid cords used in the construction offer high tensile strength and minimum stretch. These belts are best suited for heavy shock-loads and are designed to withstand high temperatures.

FEATURES:

- Specially designed EPDM orange-top-rubber for enhanced flexibility and resistant to high temperature
- The Aramid cord reinforcement provides excellent tensile strength to the belts with minimum stretch, which facilitates the belt to perform even under extreme operating conditions
- Superior grip on small diameter pulleys, capable to transmit high power
- Lower slippage, which adds to the product life and efficiency
- Extended service life without maintenance
- Temperature Range -13°F to 266°F (-25°C to 130°C)

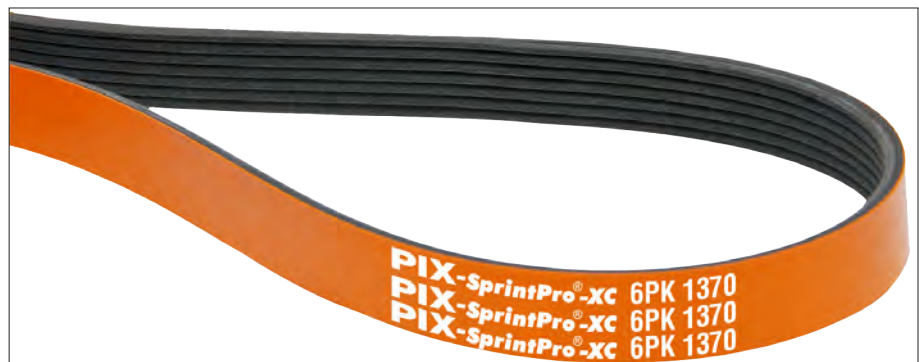

WHITEKNIGHT®-XR POWERSPORT BELTS

Section	Top Width (in)	Top Width (mm)	Belt Thickness (in)	Belt Thickness (mm)	Belt Angle (Degree)	Mfg. Range in. (mm)	
						Min.	Max.
HD	29/32" - 1 1/2"	23 - 38	25/64" - 35/64"	10 - 14	26 - 34	33 15/32" (850)	56 11/16" (1440)
XD	1 3/16" - 1 1/2"	30 - 38	19/32" - 41/64"	15 - 16.5	26 - 28	33 15/32" (850)	47 27/32" (1215)

PIX-WHITEKNIGHT® is a high performance belt with high horsepower transmitting capacity. It contains an Aramid cord for seamless power transmission. PIX-WHITEKNIGHT® is designed to work at very low ambient temperatures, thus are very suitable to be used in snowmobiles and other low temperature applications.

FEATURES:

- Specially compounded rubber compound & Aramid cords makes PIX-WHITEKNIGHT® strong enough to meet the higher snowmobile engine RPM's and operating temperatures
- Designed with wear resistant sidewalls to manage extremely high load and rpm
- Cogged profile of the belt yield increased flexibility & longer life
- Excellent performance even when equipment needs to be clutched
- Reduced slippage during the highest levels of torque
- Designed to withstand flexing, cycling, resist fatigue & stretch
- Temperature Range -40°F to 212°F (-40°C to 100°C)



APPLICATION:

ATV/UTV, Snowmobiles, golf carts, go carts, jet skis



PIX® POWERSPORT BELTS

PIX BELT ACCESSORIES

PIX® BELT ACCESSORIES



DIGITAL TENSION METER

PIX Digital tension meter is used to correct the tension factor in a drive, thus helping the users' to attain the optimum Belt tension.

This equipment works on frequency measurement phenomenon.



ANALOG TENSION TESTER

Now you can inspect the Poly V-Belts, using "PIX-Pentagon", a composite Poly V-Belt wear-measurement gauge, which can check the wear of the ribs and the thickness of all Poly V-Belt sections.



PULLEY GAUGES

PIX Pulley Gauges are specially designed for checking the profiles of the grooves of various conventional and dual section pulleys.



BELT PROFILE GAUGE

Used for checking belt profile and angle for Wrapped Belts of all sections.



PENTAGON POLY V-BELT WEAR GAUGE

Now you can inspect the Poly V-Belts, using "PIX-Pentagon", a composite Poly V-Belt wear-measurement gauge, which can check the wear of the ribs and the thickness of all Poly V-Belt sections.



LASER GUIDED PULLEY ALIGNMENT INSTRUMENT

PIX-X'Align® (Laser-guided pulley alignment instrument) is a robust and highly effective maintenance tool, used to correct the misalignment of pulleys in a drive, to help the users to obtain the maximum service life of the Belt.



LENGTH MEASURER

Used for checking the length where size on the belt is not clearly visible.

Available in conventional, dual and flat pulley constructions.



PRODUCT KIT

Belt display kit for sales team. Comprised of 14 belts of various types. Features Belts for various application based on the requirement.



MAINTENANCE CHART

A printed poster especially developed for the maintenance staff, comprises of maintenance tips which will help in maintaining a healthy condition of the drive.

Available Sizes:
13" x 19" & 24" x 36"



DESIGN DRIVE SOFTWARE

Software for designing the drive / drive solutions for Wrap, Raw Edge, Cogged Belts, Poly V-Belts & Timing Belts



PIX SERVICE KIT

"PIX Service Kit", a composite tool kit comprising of a vast range of equipment required in maintaining drives. The components are housed in a strong ABS outer case, which is light-weight, portable and sturdy.



BELT DISPLAY ARMS

Designed to fit most 4 ft wide retail shelving units. Rails are available in depths of 3", 6", 9" & 12". Will work with standard and heavy duty retail peg hooks.

BELT DIMENSIONS

PIX[®] BELT DIMENSIONS

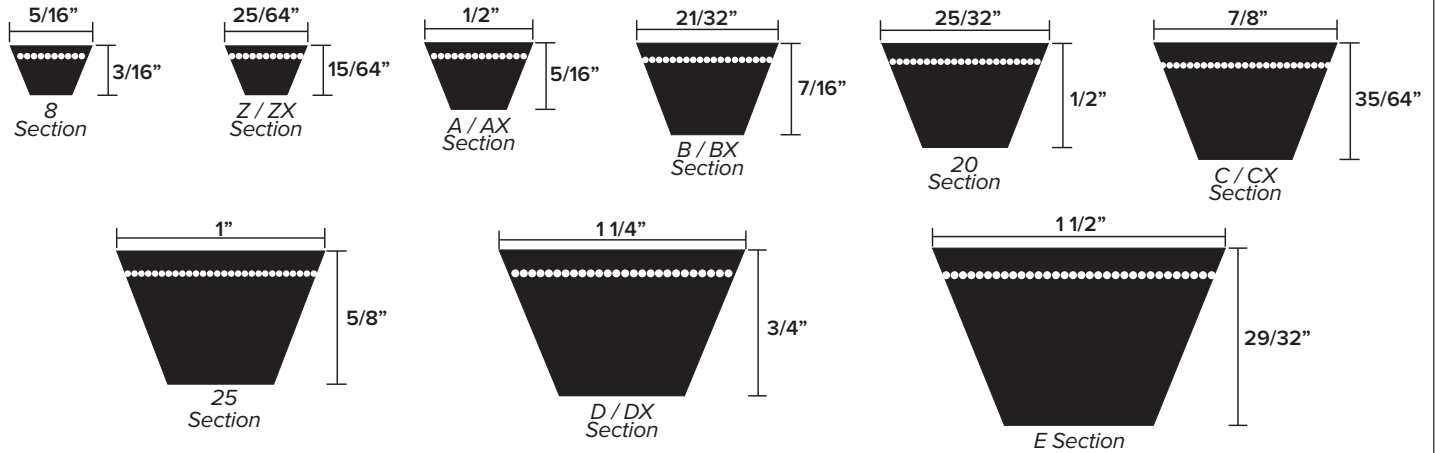

CLASSICAL SECTION Dimensions are in inches

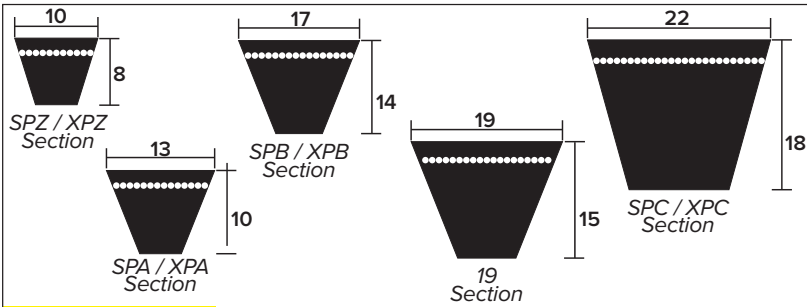

WEDGE SECTION Dimensions are in mm

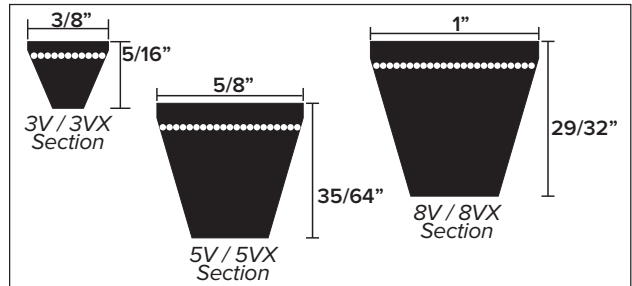

NARROW SECTION Dimensions are in inches

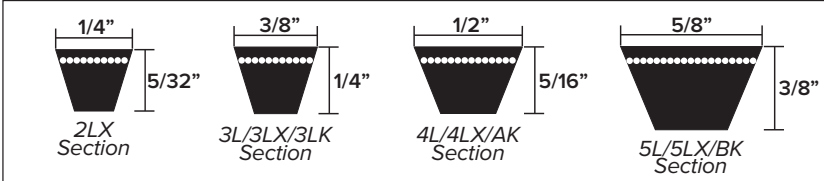

LIGHT DUTY / LAWNMASTER Dimensions are in inches

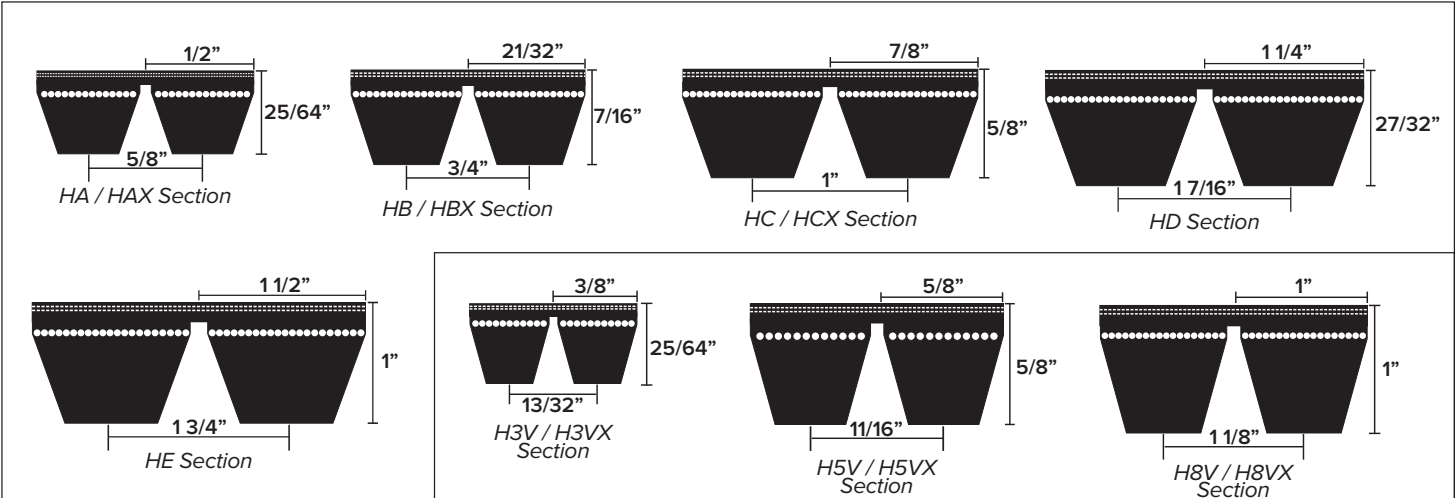

BANDED BELTS Dimensions are in inches

BANDED BELTS Dimensions are in inches

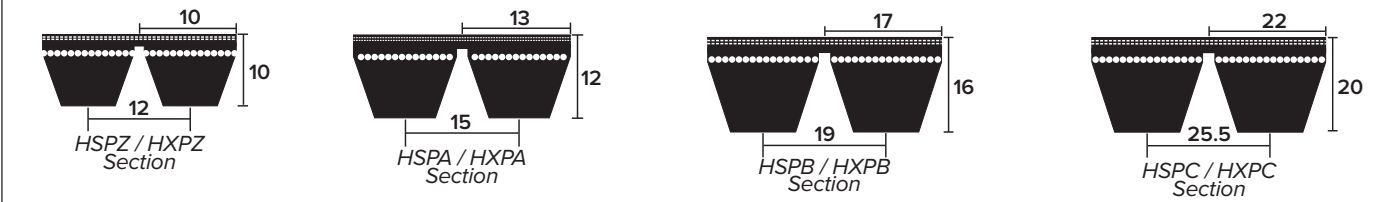

BANDED BELTS Dimensions are in mm

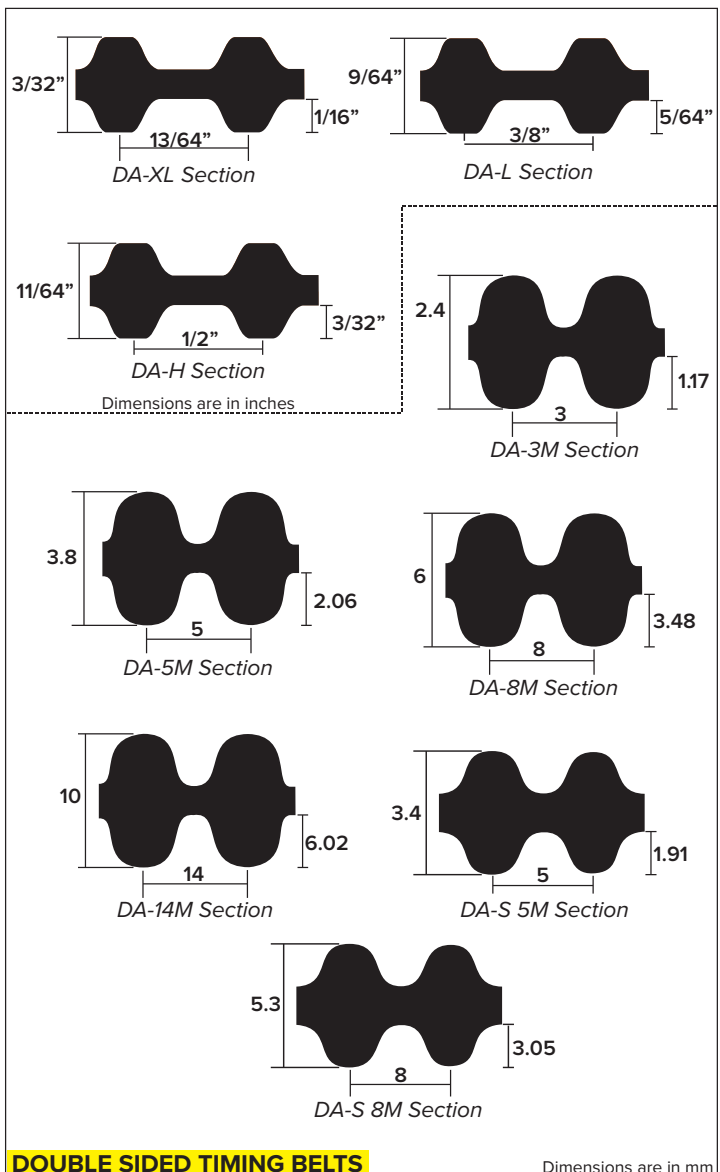
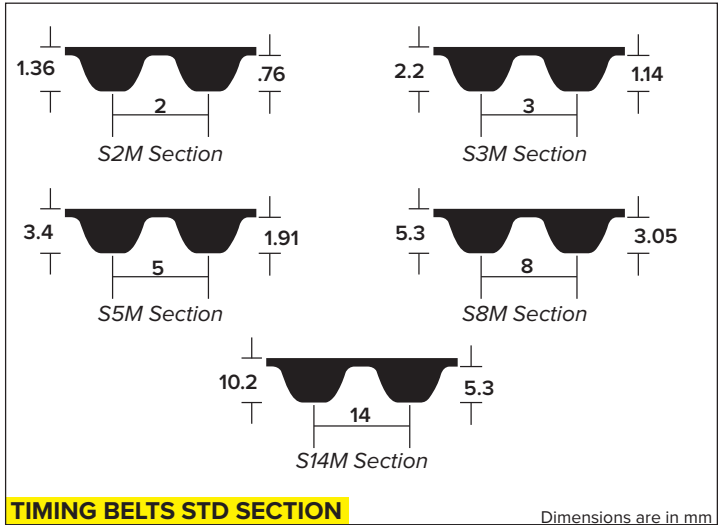
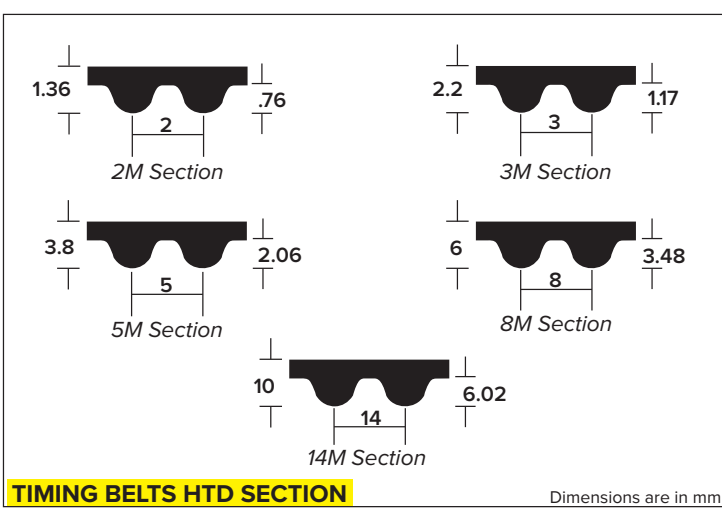
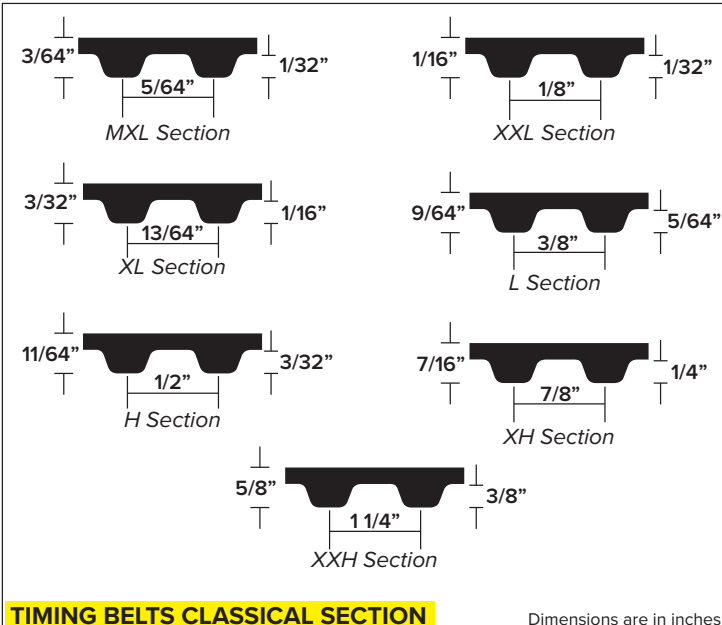
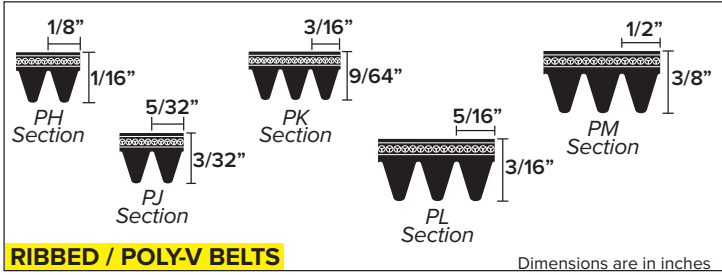
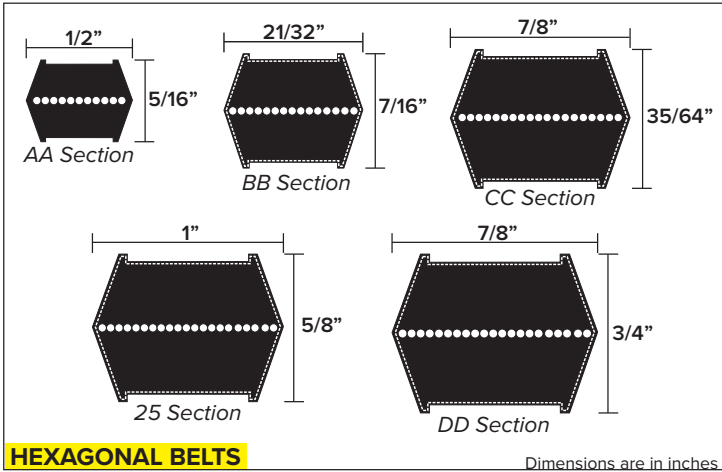

ISO 9001:2008
OHSAS: 18001
ISO/TS 16949:2009
ISO-14001

A GLOBAL LEADER IN THE PRODUCTION OF HIGH-QUALITY POWER TRANSMISSION BELTS

PIX NORTH AMERICA



1222 East Voorhees Street
Danville, Illinois 61834 USA

1 (855) 800-0720
info@pixnorthamerica.com

pixnorthamerica.com

Corporate Office:

PIX TRANSMISSIONS LIMITED
Mumbai, India
pixtrans.com

Global Offices:

PIX GERMANY GMBH
Paderborn, Germany
pixgermany.com

PIX TRANSMISSIONS (EUROPE) LIMITED
Suffolk, United Kingdom
pixtranseu.com

PIX
DRIVING GROWTH