



## Pump/Motor Mount Adaptors



## G & E SERIES MOUNTS

### G Series Mounts

G Series Motor Mounts fit most engines made by Honda, Briggs, Kohler, Kawasaki, and Subaru. These light weight aluminum castings mount directly to the engine pilot face and enable the drive of hydraulic pumps. Typically, a jaw coupling is provided with these castings as a kit.



### E Series Mounts

E Series Motor Mount Adaptors fit NEMA "C" face motors (56C thru 405 TSC) and allows the drive of hydraulic pumps (hydraulic power units). Jaw couplings can also be provided with these castings.

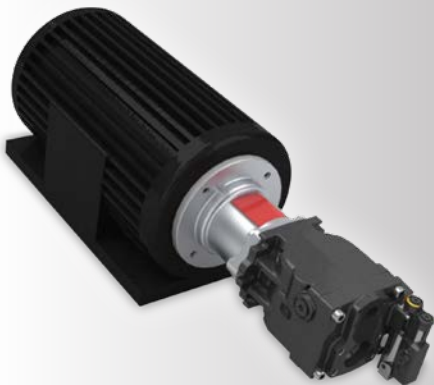

**Guardian Couplings**  
Altra Industrial Motion

## GUARDIAN INDUSTRIES PUMP/MOTOR MOUNTS

Guardian Industries Pump/Motor Mounts are designed for use with small gas engines and electric motors, which allow a direct connection to a hydraulic pump. Our castings are manufactured from a lightweight, high strength aluminum alloy. We also offer cast iron for electric motor applications. Pump mounts include a custom molded access cover which allows for easy access to inspect the drive coupling. We offer two styles of covers which include: a snap in place design, and a bolted design.

### Additional Features & Advantages:

#### Lightweight

Castings are manufactured from a high strength aluminum alloy.

#### Appearance

Eliminates the use of coupling guards and shims. Castings are produced from a permanent mold casting process. We offer various finishes upon request.

#### Minimizes Vibration

All of our castings are precision machined to strict tolerances on our state of the art CNC Equipment. After leaving production they are thoroughly inspected by our quality department which uses a coordinate measuring machine (CMM). This accomplishes accurate alignment between the motor and the pump, and reduces premature failure to the coupling element.

#### Cost Effective

Guardian mounts provide a no-hassle assembly of the pump and the motor. It eliminates the use of shims, additional mounting fixtures or foot mounts. As a result our pump mounts save our customers in labor cost and provide a worry free mounting system.

#### Availability:

- Horizontal and vertical designs
- Connects to NEMA "C" Face Electric Motors (56C Thru 445TC)
- Connects to various small gas engines (i.e. Honda, Briggs & Stratton, Kohler, Wisconsin)
- Adapts to most SAE and Metric 2 and 4 bolt pump flanges
- Various lengths
- Custom applications, no problem!



## G SERIES MOUNTS

### Small Gas Engine Adaptors – Aluminum

Guardian Industries Pump/Motor Mounts are designed for use with many small gas engines such as: Honda, Briggs & Stratton, Kohler, Lombardini, Wisconsin, and many more! Our adaptors will allow a direct connection from the engine to a hydraulic pump. These mounts are manufactured from a lightweight, high strength aluminum alloy.

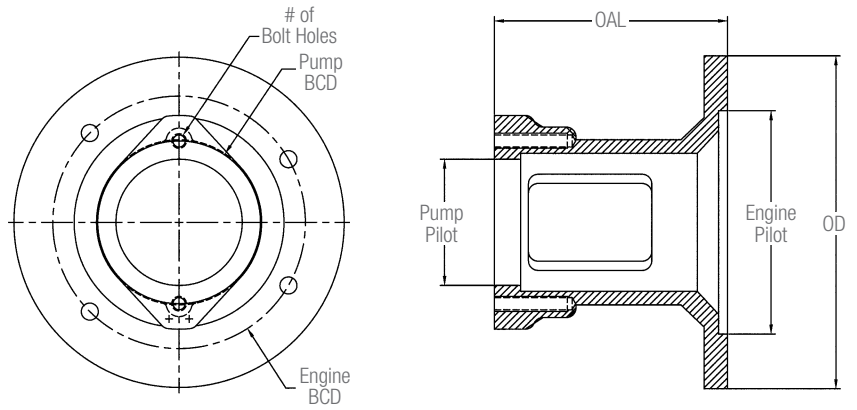

FRAME #	PUMP DATA				ENGINE DATA		OD	OAL	
	SAE CODE	# OF BOLTS	PILOT	BCD	PILOT	BCD		SHORT	LONG
GMR-98	4F17	4	1.780	2.838	5.750	6.500	7.250	4.080	
GMR-99	AA	2	2.000	3.250	5.750	6.500	7.250	4.080	
G11-103	4F17	4	1.780	2.838	NA	3.625	NA	4.690	
G11-104	4F17	4	1.780	2.838	1.625	3.625	NA	4.690	
G11-105	AA	2	2.000	3.250	NA	3.625	NA	4.690	
G11-106	AA	2	2.000	3.250	1.625	3.625	NA	4.690	
G11-107	A	2	3.250	4.188	NA	3.625	NA	4.690	
G11-108	A	2	3.250	4.188	1.625	3.625	NA	4.690	
G13-111	4F17	4	1.780	2.838	5.750	6.500	7.500	4.875	5.000
G13-112	AA	2	2.000	3.250	5.750	6.500	7.500	4.875	5.000
G13-113	A	2	3.250	4.188	5.750	6.500	7.500	4.875	5.000
G16-119	4F17	4	1.780	2.838	5.750	6.500	8.500	5.625	6.000
G16-120	4F17	4	1.780	2.838	7.000	7.750	8.500	5.625	6.000
G16-124	4F17	4	1.780	2.838	6.438	7.750	8.500	5.625	6.000
G16-127	AA	2	2.000	3.250	5.750	6.500	8.500	5.625	6.000
G16-128	AA	2	2.000	3.250	7.000	7.750	8.500	5.625	6.000
G16-131	AA	2	2.000	3.250	6.438	7.750	8.500	5.625	6.000
G16-134	A	2	3.250	4.188	5.750	6.500	8.500	5.625	6.000
G16-135	A	2	3.250	4.188	7.000	7.750	8.500	5.625	6.000
G16-138	A	2	3.250	4.188	6.438	7.750	8.500	5.625	6.000
G18-148	A	2	3.250	4.187	5.750	6.500	8.500	6.500	6.750
G18-149	A	2	3.250	4.187	7.000	7.750	8.500	6.500	6.750
G18-152	A	2	3.250	4.187	6.438	7.750	8.500	6.500	6.750
G18-155	B	2	4.000	5.750	5.750	6.500	8.500	6.500	6.750
G18-156	B	2	4.000	5.750	7.000	7.750	8.500	6.500	6.750
G18-159	B	2	4.000	5.750	6.438	7.750	8.500	6.500	6.750
G18-162	B	4	4.000	5.000	5.750	6.500	8.500	6.500	6.750
G18-163	B	4	4.000	5.000	7.000	7.750	8.500	6.500	6.750
G18-166	B	4	4.000	5.000	6.438	7.750	8.500	6.500	6.750
G21-197	A	2	3.250	4.187	5.750	6.500	8.500	5.625	6.000
G21-198	A	2	3.250	4.187	7.000	7.750	8.500	5.625	6.000
G21-201	A	2	3.250	4.187	6.438	7.750	8.500	5.625	6.000
G21-204	B	2	4.000	5.750	5.750	6.500	8.500	5.625	6.000
G21-205	B	2	4.000	5.750	7.000	7.750	8.500	5.625	6.000
G21-208	B	2	4.000	5.750	6.438	7.750	8.500	5.625	6.000
G33-232	A	2	3.250	4.187	5.750	6.500	8.750	3.500	
G33-233	A	2	3.250	4.187	7.000	7.750	8.750	3.500	
G33-234	A	2	3.250	4.187	6.438	7.750	8.750	3.500	

## E SERIES MOUNTS

### Electric Motor Adaptors – Cast Iron

Guardian Industries also offers cast iron pump/motor mounts which connect to NEMA-C face motors. Our adaptors allow a direct connection from the motor to a hydraulic pump. Although this will increase the total weight it offers superior strength and cost benefits over aluminum. We also shot blast and powder coat these for corrosion resistance and appearance.

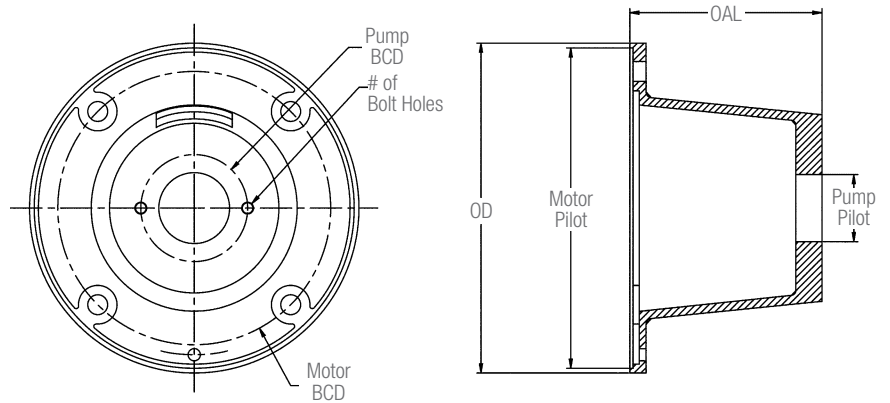

### 182 TC Thru 256 TC

FRAME #	PUMP DATA				ENGINE DATA		OD	OAL	
	SAE CODE	# OF BOLTS	PILOT	BCD	PILOT	BCD		SHORT	LONG
E54CI-A	A	2	3.250	4.187	8.500	7.250	8.750	5.810	
E54CI-B	B	2/4	4.000	5.75/5.00	8.500	7.250	8.750	5.810	
E56CI-A	A	2	3.250	4.187	8.500	7.250	8.750	6.840	
E56CI-B	B	2/4	4.000	5.75/5.00	8.500	7.250	8.750	6.840	

### 284 TC/TSC Thru 286 TC/TSC

FRAME #	PUMP DATA				ENGINE DATA		OD	OAL	
	SAE CODE	# OF BOLTS	PILOT	BCD	PILOT	BCD		SHORT	LONG
E63CI-B	B	2/4	4.000	5.75/5.00	10.500	9.000	11.000	8.000	
E63CI-C	C	2/4	5.000	7.125/6.375	10.500	9.000	11.000	8.000	

### 324 TC/TSC Thru 405 TC/TSC

FRAME #	PUMP DATA				ENGINE DATA		OD	OAL	
	SAE CODE	# OF BOLTS	PILOT	BCD	PILOT	BCD		SHORT	LONG
E68CI-B	B	2/4	4.000	5.75/5.00	12.500	11.000	13.000	8.810	
E68CI-C	C	2/4	5.000	7.125/6.375	12.500	11.000	13.000	8.810	
E68CI-D	D	2/4	6.000	9.000	12.500	11.000	13.000	8.810	

### Electric Motor Adaptors – Aluminum

Guardian Industries also offers aluminum pump/motor mounts which connect to NEMA-C face motors. Our adaptors allow a direct connection from the motor to a hydraulic pump. These pump mounts are made from a lightweight, high strength aluminum alloy.

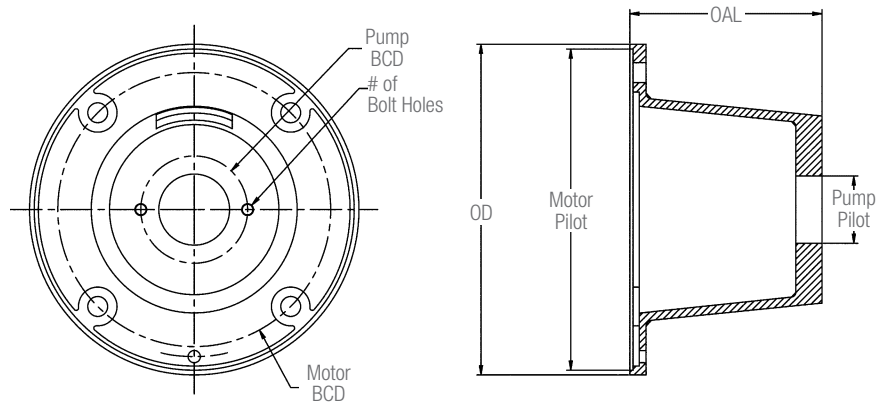

### 56 C Thru 143/145 TC

FRAME #	PUMP DATA				ENGINE DATA		OD	OVERALL LENGTH
	SAE CODE	# OF BOLTS	PILOT	BCD	PILOT	BCD		
E48X-4F17	4F17	4	1.780	2.838	4.500	5.875	6.500	3.250
E48X-AA	AA	2	2.000	3.250	4.500	5.875	6.640	3.250
E48X-A	A	2	3.250	4.187	4.500	5.875	6.640	3.250
E49X-4F17	4F17	4	1.780	2.838	4.500	5.875	6.500	4.250
E49X-AA	AA	2	2.00	3.250	4.500	5.875	6.500	4.250
E49X-A	A	2	3.250	4.187	4.500	5.875	6.500	4.250
E50-AA	AA	2	2.000	3.250	4.500	5.875	6.640	4.140

**182–184 TC/TSC Thru 254–256 TC/TSC**

FRAME #	PUMP DATA				ENGINE DATA		OD	OVERALL LENGTH
	SAE CODE	# OF BOLTS	PILOT	BCD	PILOT	BCD		
E51X-4F17	4F17	4	1.780	2.838	8.500	7.250	8.750	5.000
E51X-AA	AA	2	2.000	3.250	8.500	7.250	8.750	5.000
E51X-A	A	2	3.250	4.187	8.500	7.250	8.750	5.000
E54X-A	A	2	3.250	4.187	8.500	7.250	8.750	5.810
E54X-B	B	2/4	4.000	5.750/5.000	8.500	7.250	8.750	5.810
E54X-C	C	2	5.000	7.125	8.500	7.250	8.750	5.810
E56X-A	A	2	3.250	4.187	8.500	7.250	8.750	6.810
E56X-B	B	2/4	4.000	5.750/5.000	8.500	7.250	8.750	5.810
E56X-C	C	2	5.000	7.125	8.500	7.250	8.750	6.810
E57S-4F17	4F17	4	1.780	2.838	8.500	7.250	8.750	4.860
E57S-AA	AA	2	2.000	3.250	8.500	7.250	8.750	4.860
E57S-A	A	2	3.250	4.187	8.500	7.250	8.750	4.860
E57-AA	AA	2	2.000	3.250	8.500	7.250	8.750	5.105
E57-A	A	2	3.250	4.187	8.500	7.250	8.750	5.105
E57L-A	A	2	3.250	4.187	8.500	7.250	8.750	5.930

**284 TC/TSC Thru 286 TC/TSC**

FRAME #	PUMP DATA				ENGINE DATA		OD	OVERALL LENGTH
	SAE CODE	# OF BOLTS	PILOT	BCD	PILOT	BCD		
E62X-A	A	2	3.250	4.187	10.500	9.000	11.000	6.870
E62X-B	B	2/4	4.000	5.750/5.000	10.500	9.000	11.000	6.870
E62X-C	C	2/4	5.000	7.125/6.375	10.500	9.000	11.000	6.870
E63X-A	A	2	3.250	4.187	10.500	9.000	11.000	8.680
E63X-B	B	2/4	4.000	5.750/5.000	10.500	9.000	11.000	8.680
E63X-C	C	2/4	5.000	7.125/6.375	10.500	9.000	11.000	8.680

**324 TC/TSC Thru 405 TC/TSC**

FRAME #	PUMP DATA				ENGINE DATA		OD	OVERALL LENGTH
	SAE CODE	# OF BOLTS	PILOT	BCD	PILOT	BCD		
E65X-B	B	2/4	4.000	5.750/5.000	12.500	11.000	13.060	7.620
E65X-C	C	2/4	5.000	7.125/6.375	12.500	11.000	13.060	7.620
E65X-D	D	2	6.000	9.000	12.500	11.000	13.060	7.620
E66X-B	B	2/4	4.000	5.750/5.000	12.500	11.000	13.060	8.750
E66X-C	C	2/4	5.000	7.125/6.375	12.500	11.000	13.060	8.750
E66X-D2	D	2	6.000	9.000	12.500	11.000	13.060	8.750
E66X-D4	D	4	6.000	9.000	12.500	11.000	13.060	8.750

**444 TSC Thru 445 TSC**

FRAME #	PUMP DATA				ENGINE DATA		OD	OVERALL LENGTH
	SAE CODE	# OF BOLTS	PILOT	BCD	PILOT	BCD		
E76X-C	C	2/4	5.000	7.125/6.375	16.000	14.000	16.750	8.750
E76X-D	D	2/4	6.000	9.000	16.000	14.000	16.750	8.750
E76X-E	E	2	6.500	12.500	16.000	14.000	16.750	8.750
E76X-F	F	2	7.000	13.781	16.000	14.000	16.750	8.750

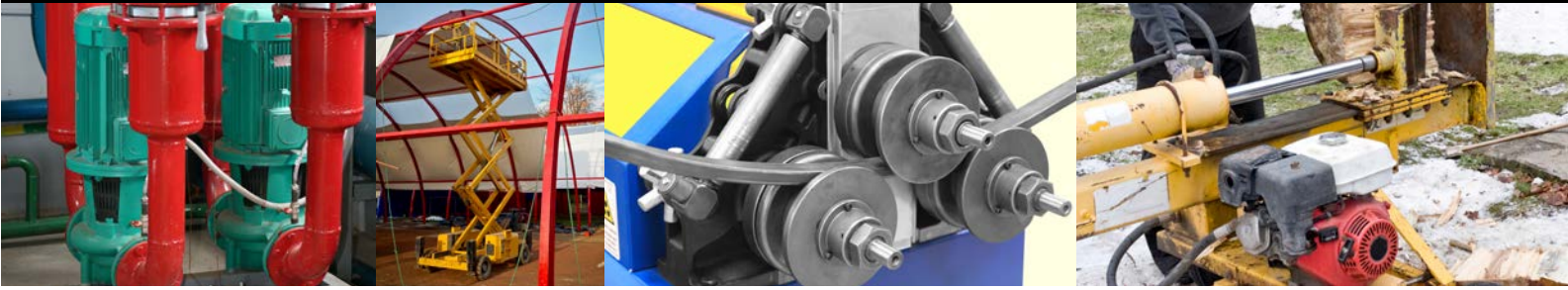

## VERTICAL MOUNTS

### Electric Motor Adaptors – Aluminum

Guardian Industries also offers aluminum pump/motor mounts for vertical applications to connect to a NEMA-C face motor.

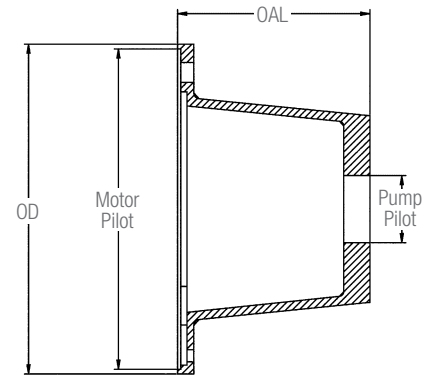
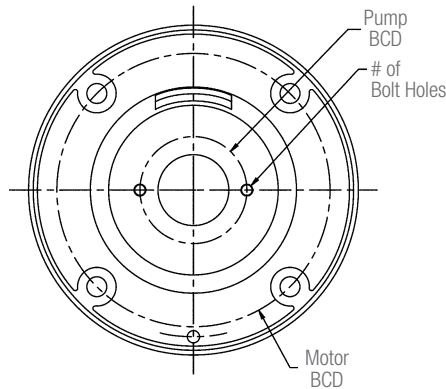

### 182 TC Thru 256 TC

FRAME #	PUMP DATA				ENGINE DATA		OD	OVERALL LENGTH
	SAE CODE	# OF BOLTS	PILOT	BCD	PILOT	BCD		
V75	A	2	3.250	4.187	8.500	7.250	8.750	5.188

### Fabricated Vertical Mounts

For vertical applications, Guardian can custom fabricate mounts for NEMA "C" frames in the size 56 C to 405 C.

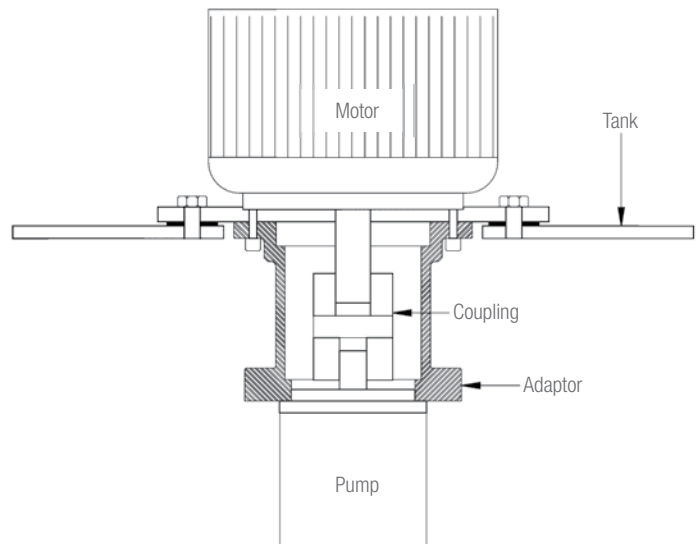



## CUSTOM ENGINEERED SOLUTIONS

### Fabricated Adaptors

- Various mounting patterns and features for both the drive and driven components
- Adjustable lengths
- All steel construction
- Stainless steel available upon request

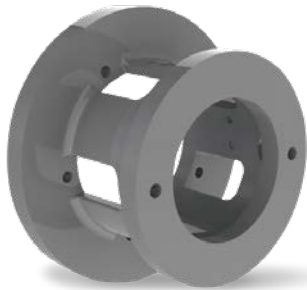

### Direct & Belt Drive Kit

- Direct mount to the motor and pump
- Open-faced adaptor which allows for clearance of the belt
- Specially machined belt groove on the coupling hub

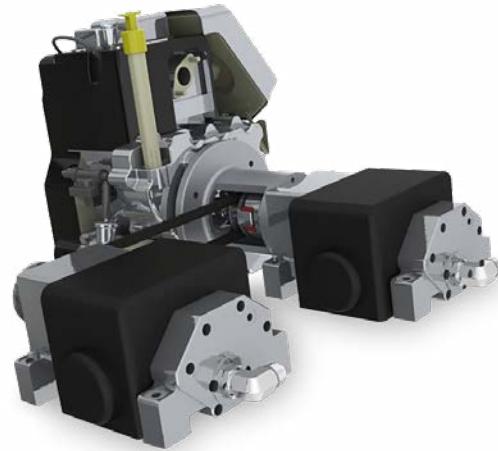

### Foot Mounted Bracket

- Fabricated foot mounted bracket for mounting a hydraulic pump
- Adjustable foot mounting distance and configurations



### Base Plates

- Various mounting configurations
- Various plate thickness

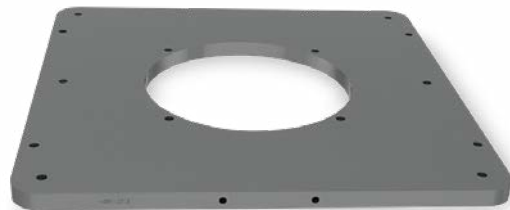

## ELECTRIC MOTOR INFORMATION

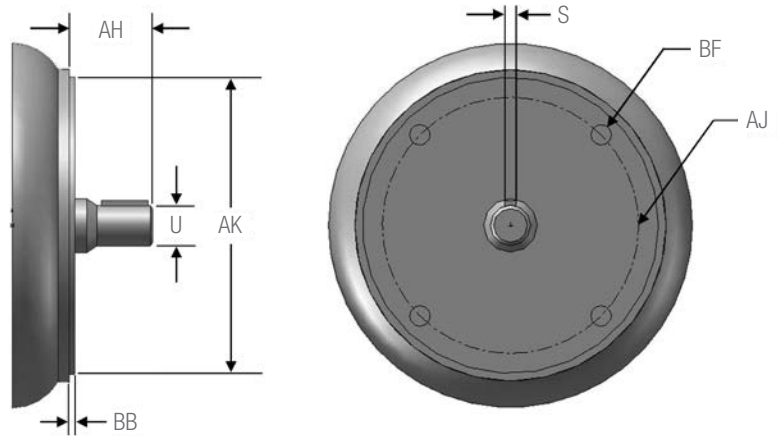

## “T” Frame Electric Motor Information

NEMA		BOLT CIRCLE (AJ)	PILOT (AK)	PILOT DEPTH (BB)	SHAFT DIAMETER (U)	SHAFT LENGTH (AH)	KEY WIDTH (S)	TAPPED HOLES (BF)		
MOTOR	FRAME							QTY	SIZE	BOLT PENETRATION ALLOWANCE
	56C	5-7/8	4-1/2	0.16	5/8	2-1/16	3/16	4	3/8-16	---
	143TC	5-7/8	4-1/2	0.16	7/8	2-1/8	3/16	4	3/8-16	0.56
	145TC	5-7/8	4-1/2	0.16	7/8	2-1/8	3/16	4	3/8-16	0.56
	182TC	7-1/4	8-1/2	0.16	1-1/8	2-5/8	1/4	4	1/2-13	0.75
	184TC	7-1/4	8-1/2	0.16	1-1/8	2-5/8	1/4	4	1/2-13	0.75
	213TC	7-1/4	8-1/2	0.25	1-3/8	3-1/8	5/16	4	1/2-13	0.75
	215TC	7-1/4	8-1/2	0.25	1-3/8	3-1/8	5/16	4	1/2-13	0.75
	254TC	7-1/4	8-1/2	0.25	1-5/8	3-3/4	3/8	4	1/2-13	0.75
	256TC	7-1/4	8-1/2	0.25	1-5/8	3-3/4	3/8	4	1/2-13	0.75
284TSC	284TC	9	10-1/2	0.25	1-7/8	4-3/8	1/2	4	1/2-13	0.75
		9	10-1/2	0.25	1-5/8	3	3/8	4	1/2-13	0.75
	286TC	9	10-1/2	0.25	1-7/8	4-3/8	1/2	4	1/2-13	0.75
286TSC		9	10-1/2	0.25	1-5/8	3	3/8	4	1/2-13	0.75
324TSC	324TC	11	12-1/2	0.25	2-1/8	5	1/2	4	5/8-11	0.94
		11	12-1/2	0.25	1-7/8	3-1/2	1/2	4	5/8-11	0.94
	326TC	11	12-1/2	0.25	2-1/8	5	1/2	4	5/8-11	0.94
326TSC		11	12-1/2	0.25	1-7/8	3-1/2	1/2	4	5/8-11	0.94
364TSC	364TC	11	12-1/2	0.25	2-3/8	5-5/8	5/8	8	5/8-11	0.94
		11	12-1/2	0.25	1-7/8	3-1/2	1/2	8	5/8-11	0.94
	365TC	11	12-1/2	0.25	2-3/8	5-5/8	5/8	8	5/8-11	0.94
365TSC		11	12-1/2	0.25	1-7/8	3-1/2	1/2	8	5/8-11	0.94
404TSC	404TC	11	12-1/2	0.25	2-7/8	7	3/4	8	5/8-11	0.94
		11	12-1/2	0.25	2-1/8	4	1/2	8	5/8-11	0.94
	405TC	11	12-1/2	0.25	2-7/8	7	3/4	8	5/8-11	0.94
405TSC		11	12-1/2	0.25	2-1/8	4	1/2	8	5/8-11	0.94
444TSC	444TC	14	16	0.25	3-3/8	8-1/4	7/8	8	5/8-11	0.94
		14	16	0.25	2-3/8	4-1/2	5/8	8	5/8-11	0.94
445TSC	445TC	14	16	0.25	3-3/8	8-1/4	7/8	8	5/8-11	0.94
		14	16	0.25	2-3/8	4-1/2	5/8	8	5/8-11	0.94
447TSC	447TC	14	16	0.25	3-3/8	8-1/4	7/8	8	5/8-11	0.94
		14	16	0.25	2-3/8	4-1/2	5/8	8	5/8-11	0.94
449TSC	449TC	14	16	0.25	3-3/8	8-1/4	7/8	8	5/8-11	0.94
		14	16	0.25	2-3/8	4-1/2	5/8	8	5/8-11	0.94



### “U” Frame Electric Motor Information

NEMA		BOLT CIRCLE (AJ)	PILOT (AK)	PILOT DEPTH (BB)	SHAFT DIAMETER (U)	SHAFT LENGTH (AH)	KEY WIDTH (S)	TAPPED HOLES (BF)		
MOTOR	FRAME							QTY	SIZE	BOLT PENETRATION ALLOWANCE
	182UC	5-7/8	4-1/2	0.16	7/8	2-1/8	3/16	4	3/8-16	0.56
	184UC	5-7/8	4-1/2	0.16	7/8	2-1/8	3/16	4	3/8-16	0.56
	213UC	7-1/4	8-1/2	0.25	1-1/8	2-3/4	1/4	4	1/2-13	0.75
	215UC	7-1/4	8-1/2	0.25	1-1/8	2-3/4	1/4	4	1/2-13	0.75
	254UC	7-1/4	8-1/2	0.25	1-3/8	3-1/2	5/16	4	1/2-13	0.75
	256UC	7-1/4	8-1/2	0.25	1-3/8	3-1/2	5/16	4	1/2-13	0.75
	284UC	9	10-1/2	0.25	1-5/8	4-5/8	3/8	4	1/2-13	0.75
	286UC	9	10-1/2	0.25	1-5/8	4-5/8	3/8	4	1/2-13	0.75
324USC	324UC	11	12-1/2	0.25	1-7/8	5-3/8	1/2	4	5/8-11	0.94
		11	12-1/2	0.25	1-5/8	3	3/8	4	5/8-11	0.94
326USC	326UC	11	12-1/2	0.25	1-7/8	5-3/8	1/2	4	5/8-11	0.94
		11	12-1/2	0.25	1-5/8	3	3/8	4	5/8-11	0.94
364USC	364UC	11	12-1/2	0.25	2-1/8	6-1/8	1/2	8	5/8-11	0.94
		11	12-1/2	0.25	1-7/8	3-1/2	1/2	8	5/8-11	0.94
	365UC	11	12-1/2	0.25	2-1/8	6-1/8	1/2	8	5/8-11	0.94
365USC		11	12-1/2	0.25	1-7/8	3-1/2	1/2	8	5/8-11	0.94
404USC	404UC	11	12-1/2	0.25	2-3/8	6-7/8	5/8	8	5/8-11	0.94
		11	12-1/2	0.25	2-1/8	4	1/2	8	5/8-11	0.94
	405UC	11	12-1/2	0.25	2-3/8	6-7/8	5/8	8	5/8-11	0.94
405USC		11	12-1/2	0.25	2-1/8	4	1/2	8	5/8-11	0.94
444USC	444UC	14	16	0.25	2-7/8	8-3/8	3/4	8	5/8-11	0.94
		14	16	0.25	2-1/8	4	1/2	8	5/8-11	0.94
	445UC	14	16	0.25	2-7/8	8-3/8	3/4	8	5/8-11	0.94
445USC		14	16	0.25	2-1/8	4	1/2	8	5/8-11	0.94

### PUMP MOUNTING FLANGE INFORMATION

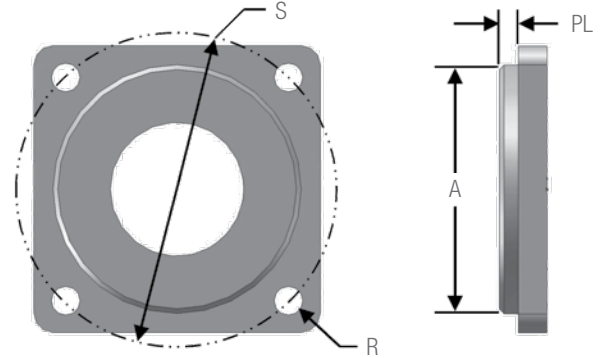
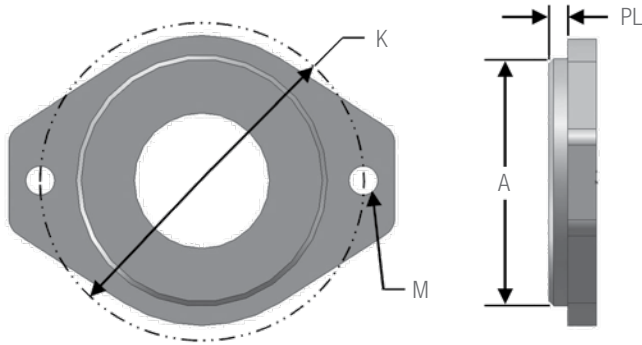

#### SAE 2 Bolt Mounting Flanges

MOUNTING FLANGE			PILOT DIMENSIONS		FLANGE DIMENSIONS	
ANSI	USA	SAE	A	K	M	
50-2	-	AA	2.000	3.250	0.406	
82-2	2F32	A	3.250	4.187	0.438	
101-2	2F40	B	4.000	5.750	0.562	
127-2	2F50	C	5.000	7.125	0.687	
152-2	2F60	D	6.000	9.000	0.812	
165-2	2F65	E	6.500	12.500	1.062	
177-2	2F70	F	7.000	13.781	1.062	

#### SAE 4 Bolt Mounting Flanges

MOUNTING FLANGE			PILOT DIMENSIONS		FLANGE DIMENSIONS	
ANSI	USA	SAE	A	S	R	
-	4F17	AA	1.781	2.838	0.375	
82-4	4F32	A	3.250	4.125	0.438	
101-4	4F40	B	4.000	5.000	0.562	
127-4	4F50	C	5.000	6.375	0.562	
152-4	4F60	D	6.000	9.000	0.812	
165-4	4F65	E	6.500	12.500	0.812	
177-4	4F70	F	7.000	13.781	1.062	

**Note:** Metric 2 & 4 bolt mounting may only be available for some configurations, please contact factory for further details.

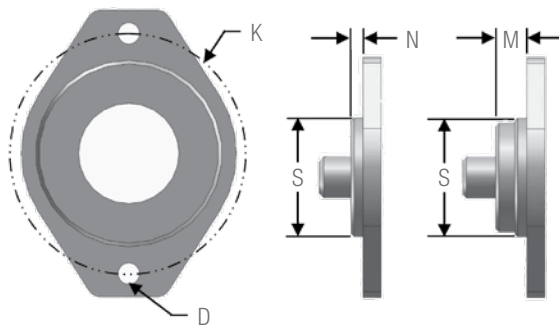

**Metric 2 Bolt Mount (Oval)**

MOUNTING FLANGE	PILOT	BOLT CIRCLE	HOLES	SHORT SPIGOT	LONG SPIGOT
	S	K	D	N	M
32 A2	32	56	6.6	8	16
40 A2	40	63	6.6	8	16
50 A2	50	80	9	8	20
63 A2	63	100	9	8	20
80 A2	80	109	11	8	20
100 A2	100	140	14	10	25
112 A2	112	160	14	10	25
125 A2	125	180	18	10	32
140 A2	140	200	18	10	32
160 A2	160	224	22	10	40
180 A2	180	250	22	10	40
200 A2	200	280	26	10	50

(All dimensions in mm)

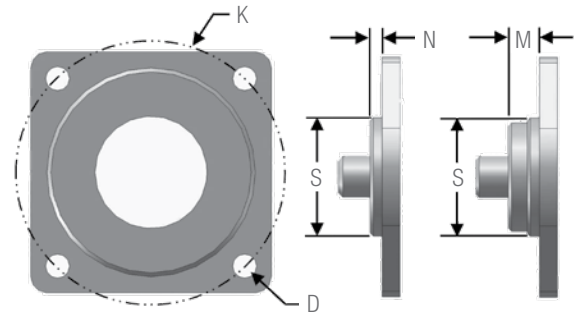

**Metric 4 Bolt Mount (Square)**

MOUNTING FLANGE	PILOT	BOLT CIRCLE	HOLES	SHORT SPIGOT	LONG SPIGOT
	S	K	D	N	M
63 B4	63	85	9	8	20
80 B4	80	103	9	8	20
80 S4	80	100	9	8	20
100 B4	100	125	11	10	25
112 B4	112	140	11	10	25
125 B4	125	160	14	10	32
140 B4	140	180	14	10	32
160 B4	160	200	18	10	40
180 B4	180	224	18	10	40
200 B4	200	250	22	10	50
224 B4	224	280	22	10	50
250 B4	250	315	26	10	50

(All dimensions in mm)

**PUMP SHAFT INFORMATION**

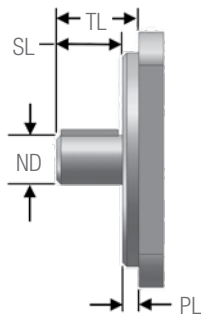

**Straight Shaft Types**

DIA.	SHORT SHAFT LENGTH	SHORT SHAFT	LONG SHAFT LENGTH	LONG SHAFT	KEY WIDTH	PILOT LENGTH
ND	SL	TL	SL	TL		PL
0.500	0.750	1.063	-	-	0.125	0.250
0.625	0.938	1.250	2.000	2.313	0.156	0.250
0.750	0.938	1.250	2.000	2.313	0.187	0.250
0.875	1.312	1.625	2.500	2.813	0.250	0.375
1.000	1.500	1.812	2.750	3.063	0.250	0.375
1.250	1.875	2.187	3.000	3.313	0.312	0.500
1.500	2.125	2.437	3.250	3.563	0.375	0.500
1.750	2.625	2.937	3.625	3.938	0.437	0.500

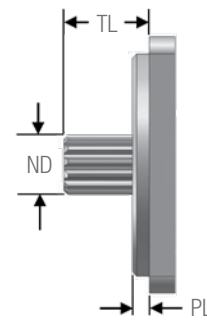

**SAE Involute Spline Types**

SAE CODE	# OF TEETH	DIA. PITCH	PRESSURE ANGLE	MAJOR DIA.	TOTAL LENGTH
		DP	PA	ND	TL
AA	9	20/40	30°	0.500	1.062
A	9	16/32	30°	0.625	1.250
AH	11	16/32	30°	0.750	1.250
B	13	16/32	30°	0.875	1.625
BB	15	16/32	30°	1.000	1.812
C	14	12/24	30°	1.250	2.187
CS	21	16/32	30°	1.375	2.187
CC	17	12/24	30°	1.500	2.437
D	13	8/16	30°	1.750	2.937
E	13	8/16	30°	1.750	2.937
F	15	8/16	30°	2.000	3.437



## ABOUT GUARDIAN COUPLINGS

For more than 70 years, Guardian has been designing and manufacturing world-class couplings and other power transmission components. Utilizing advanced manufacturing technologies and processes, Guardian provides highly-reliable coupling and component solutions to meet the most challenging industrial application requirements.

Guardian provides a wide range of standard and custom products including flywheel couplings, hydraulic pump mounts, bearing supported stub shafts, flexible shaft-to-shaft couplings, motion control couplings as well as compression pipe couplings.

Durable Guardian products are utilized in key industries including mobile hydraulics, farm & ag, tree care, concrete, food & beverage, material handling, automation, power generation, and oil & gas on applications such as skid steers, aerial lifts, harvesters, wood chippers, concrete pumps, dewatering pumps, baggage handlers, conveyors, robotics, compressors, and generator sets.



## ALTRA COUPLINGS

Altra Couplings offers the largest selection of industrial couplings available from a single source...worldwide. For over 150 years, TB Wood's, Ameridrives, Bibby Turboflex, Lamiflex, Guardian and Huco, the industry-leading brands of Altra Couplings have been providing innovative coupling solutions to meet the requirements for a broad variety of drivetrain applications spanning many industries including energy, metals, mining, oil & gas, and food processing. Highly-engineered Altra coupling products represent the latest in coupling technology, featuring superior design and exceptional quality to ensure long-lasting performance in all types of environments.

## Guardian Couplings Facilities

### North America

#### USA

300 Indiana Highway 212  
Michigan City, IN 46360  
219-874-5248

*Engineered Flywheel Couplings, Engine Housings and Pump Mounts, Flexible Shaft Couplings*

### Europe

#### United Kingdom

Merchant Drive, Hertford  
Hertfordshire SG13 7BL - England  
+44(0)1992 501900

*Engineered Flywheel Couplings, Engine Housings and Pump Mounts, Flexible Shaft Couplings*

## The Brands of Altra Motion

### Couplings

**Ameridrives**  
[www.ameridrives.com](http://www.ameridrives.com)

**Bibby Turboflex**  
[www.bibbyturboflex.com](http://www.bibbyturboflex.com)

**Guardian Couplings**  
[www.guardiancouplings.com](http://www.guardiancouplings.com)

**Huco**  
[www.huco.com](http://www.huco.com)

**Lamiflex Couplings**  
[www.lamiflexcouplings.com](http://www.lamiflexcouplings.com)

**Stromag**  
[www.stromag.com](http://www.stromag.com)

**TB Wood's**  
[www.tbwoods.com](http://www.tbwoods.com)

### Linear Systems

**Thomson**  
[www.thomsonlinear.com](http://www.thomsonlinear.com)

**Warner Linear**  
[www.warnerlinear.com](http://www.warnerlinear.com)

### Geared Cam Limit Switches

**Stromag**  
[www.stromag.com](http://www.stromag.com)

### Engineered Bearing Assemblies

**Kilian**  
[www.kilianbearings.com](http://www.kilianbearings.com)

### Electric Clutches & Brakes

**Matrix**  
[www.matrix-international.com](http://www.matrix-international.com)

**Stromag**  
[www.stromag.com](http://www.stromag.com)

**Warner Electric**  
[www.warnerelectric.com](http://www.warnerelectric.com)

**Deltran**  
[www.thomsonlinear.com](http://www.thomsonlinear.com)

### Belted Drives

**TB Wood's**  
[www.tbwoods.com](http://www.tbwoods.com)

### Heavy Duty Clutches & Brakes

**Twiflex**  
[www.twiflex.com](http://www.twiflex.com)

**Stromag**  
[www.stromag.com](http://www.stromag.com)

**Svendborg Brakes**  
[www.svendborg-brakes.com](http://www.svendborg-brakes.com)

**Wichita Clutch**  
[www.wichitaclutch.com](http://www.wichitaclutch.com)

### Gearing & Specialty Components

**Bauer Gear Motor**  
[www.bauergears.com](http://www.bauergears.com)

**Boston Gear**  
[www.bostongear.com](http://www.bostongear.com)

**Delevan**  
[www.delevan.com](http://www.delevan.com)

**Delroyd Worm Gear**  
[www.delroyd.com](http://www.delroyd.com)

**Nuttall Gear**  
[www.nuttallgear.com](http://www.nuttallgear.com)

### Engine Braking Systems

**Jacobs Vehicle Systems**  
[www.jacobsvehiclesystems.com](http://www.jacobsvehiclesystems.com)

### Precision Motors & Automation

**Kollmorgen**  
[www.kollmorgen.com](http://www.kollmorgen.com)

### Miniature Motors

**Portescap**  
[www.portescap.com](http://www.portescap.com)

### Overrunning Clutches

**Formsprag Clutch**  
[www.formsprag.com](http://www.formsprag.com)

**Marland Clutch**  
[www.marland.com](http://www.marland.com)

**Stieber**  
[www.stieberclutch.com](http://www.stieberclutch.com)

Neither the accuracy nor completeness of the information contained in this publication is guaranteed by the company and may be subject to change in its sole discretion. The operating and performance characteristics of these products may vary depending on the application, installation, operating conditions and environmental factors. The company's terms and conditions of sale can be viewed at <http://www.altramotion.com/terms-and-conditions/sales-terms-and-conditions>. These terms and conditions apply to any person who may buy, acquire or use a product referred to herein, including any person who buys from a licensed distributor of these branded products.

©2018 by Guardian Couplings LLC. All rights reserved. All trademarks in this publication are the sole and exclusive property of Guardian Couplings LLC or one of its affiliated companies.

