

■ DRP ■ KRFX ■ KRP

REDEX offers the **most comprehensive range in machine-tool drives.**

The integrated output pinion exclusive design is at the core of the largest range of servo-reducers fully dedicated to Linear & Rotary Axis Drives.

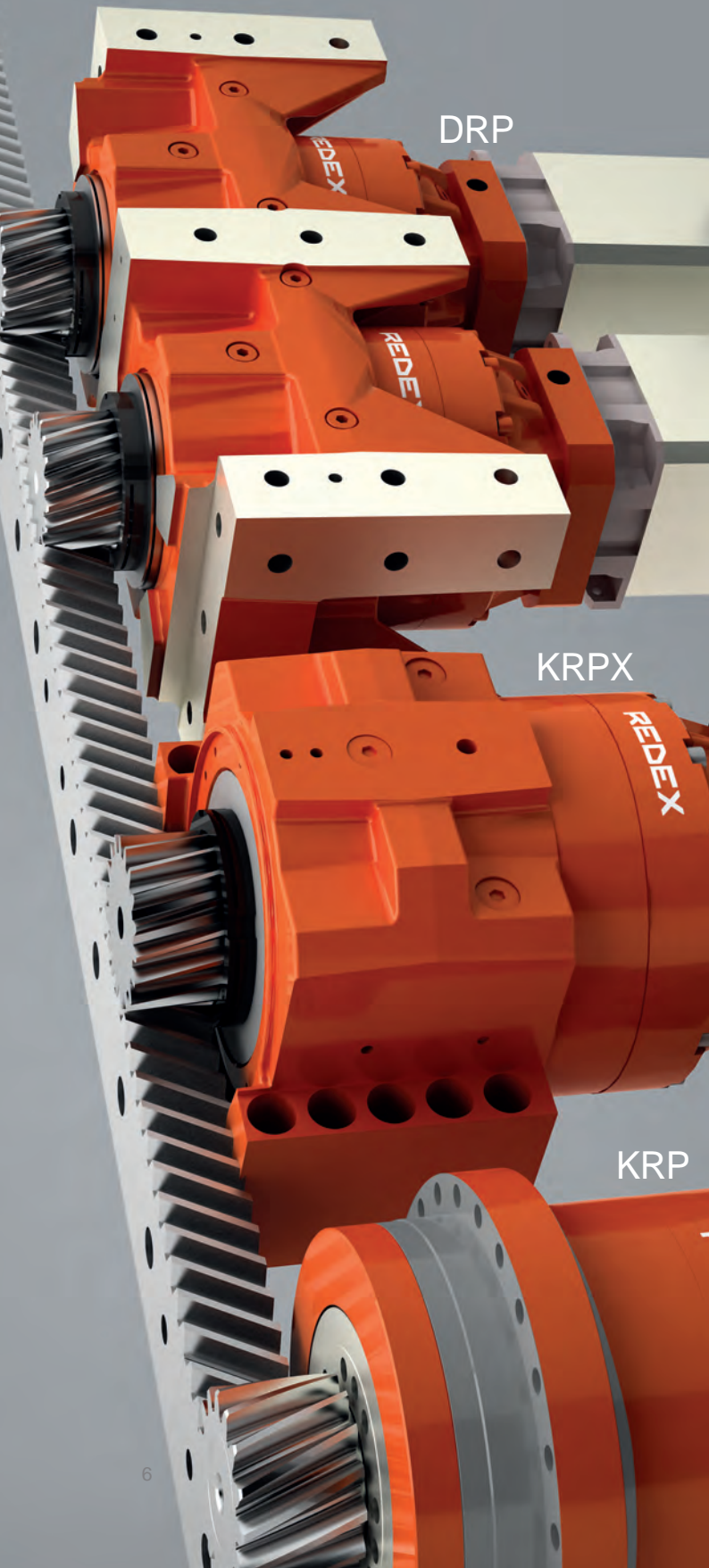

Linear & Rotary Axis Drive

Flange mounting, Side mounting, or Universal housing, REDEX provides the optimized axis drive solution.

- › Original design
- › Zero backlash electrical or mechanical preload available
- › Stiffness optimized design, ideal for highly dynamic linear or rotary servo-axes
- › 100% compliant with machine-tool quality

Further **information & calculation tools** available on request.

 my REDEX

DriveSizer®

www.my-redex.com



Range Summary

through Application Force

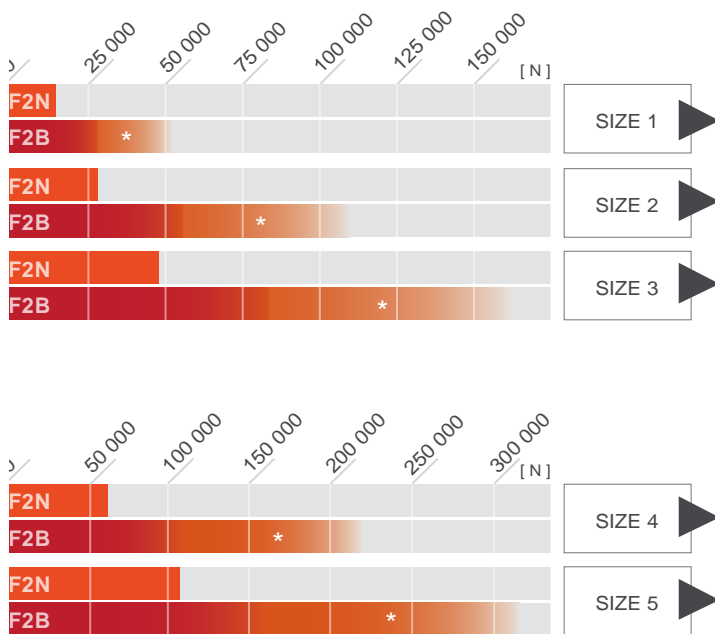

* F2B extension zone for 2 drives sharing the load
Actual value depends on the preload parameters

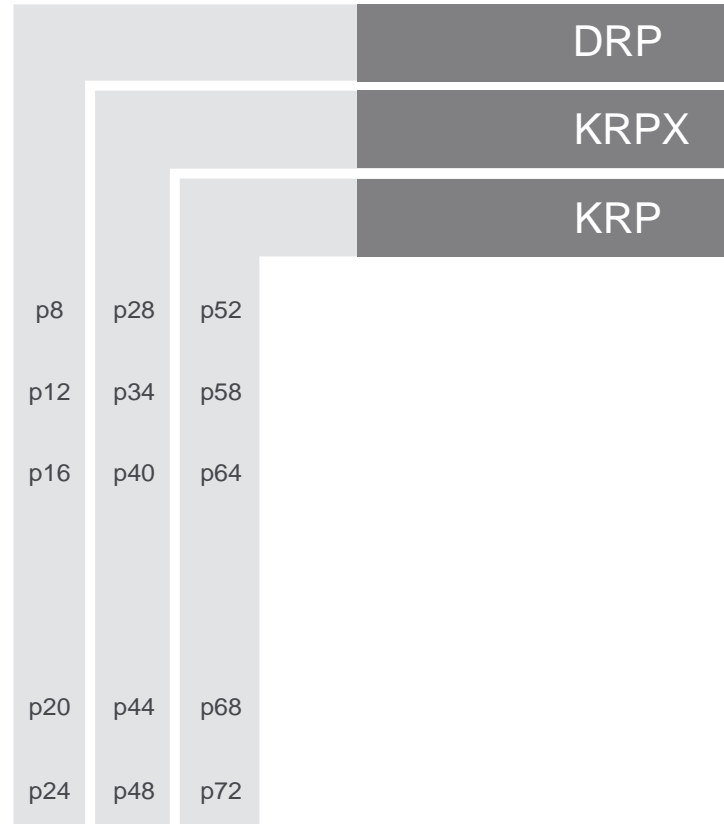

All above data related to Ratio 31

Optimization of the Application Force [N]

through Electrical or Mechanical Preload

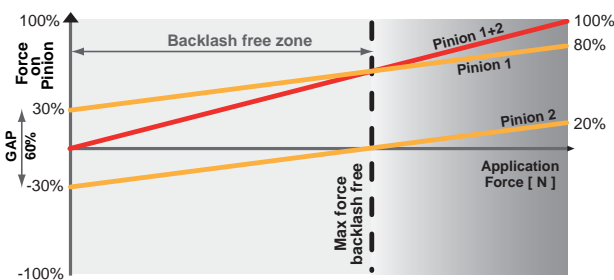

Electrical Drive solution
Example with 60% preload

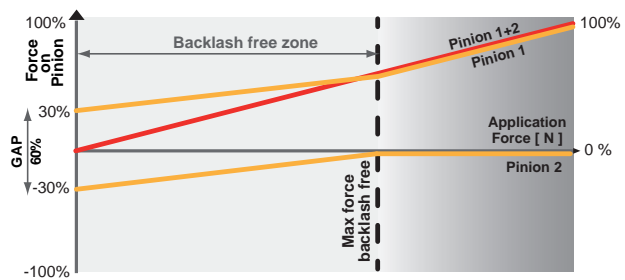

Mechanical Drive solution
Example with 60% preload

DRP SIZE 1



DRP1

Weight

Efficiency

Backlash

Color

Tooth type

Module

Helix angle (left)

Number of teeth

Pressure angle

Theoretical pitch diameter

Addendum modification factor

Pinion quality grade

Surface hardness

Ratio

Nominal feed force

Peak acceleration feed force

Max. acceleration feed force

E-stop force

Max. linear speed

Nominal linear speed

Linear stiffness on the rack

Inertia

Ratio

Nominal output torque

Max. output torque

No load torque

No load torque

E-stop torque

Max. input speed

Nominal input speed

Radial stiffness

Axial stiffness

Torsional stiffness

General data

			M	R
m	kg	1 Stage		
		2 Stages	109	115
η	%	1 Stage		
		2 Stages	93	91
J	arcmin	Standard	3	4
		Reduced	1	2
RAL2012				

Pinion features

		Helical	Straight
Mo	mm	3	3
β	deg	19°31'42"	0°
Z2	-	18	19
α	deg	20	20
D02	mm	57,3	57
x0	-	0,118	0,167
Q	(ISO 1328)	6	6
HRC	HRC	61-63	61-63

Rack features

Version			Helical	Straight
Standard	F2B	N	15939	13766
	F2NOT	N	31878	23940
	Material		C45E DIN 1.1191	
Reinforced	F2B	N	19562	N/A
	F2NOT	N	48904	N/A
	Material		16MnCr5	
Available length	L	mm	500, 1000, 2000	
Dimensions	see details p113-115			

Drive linear features

		5	7	10	17	21	31	46	61	91
F2N	N				13613	10646	15009	9424	13089	9424
F2B	N				23839	18639	26283	16510	22897	16510
F2B_max	N				47679	37277	52565	33019	45794	33019
F2NOT	N				29075	29075	29075	29075	29075	29075
V2B	m/min				64	51	35	23	18	12
V2N	m/min				28	22	15	10	8	5
K2T +M	N/μm				190	190	178	170	173	185
K2T +R	N/μm					169	176	169	173	185
I +M	kg.mm ²				287	269	259	254	246	245
I +R	kg.mm ²					458	448	443	435	433

DRP ratings

		5	7	10	17	21	31	46	61	91
T2N	Nm				390	305	430	270	375	270
T2B	Nm				683	534	753	473	656	473
T01 +R	Nm					1,5	1,5	1,5	1,5	1,5
T01 +M	Nm				1	1	1	1	1	1
T2NOT	Nm				833	833	833	833	833	833
n1B	rpm				6000	6000	6000	6000	6000	6000
n1N	rpm				2600	2600	2600	2600	2600	2600
K2R	N/μm				480	480	480	480	480	480
K2A	N/μm				1710	1710	1710	1710	1710	1710
C2t +R	Nm/ rad				237205	254393	237205	247518	278457	
	Nm/arcmin				69	74	69	72	81	
C2t +M	Nm/ rad				292208	292208	261269	240642	247518	278457
	Nm/arcmin				85	85	76	70	72	81

Dimensions and main data for information only - Please consult us and / or refer to Products Datasheets
For accurate selection, contact your local supplier

DIMENSIONS - TYPE M

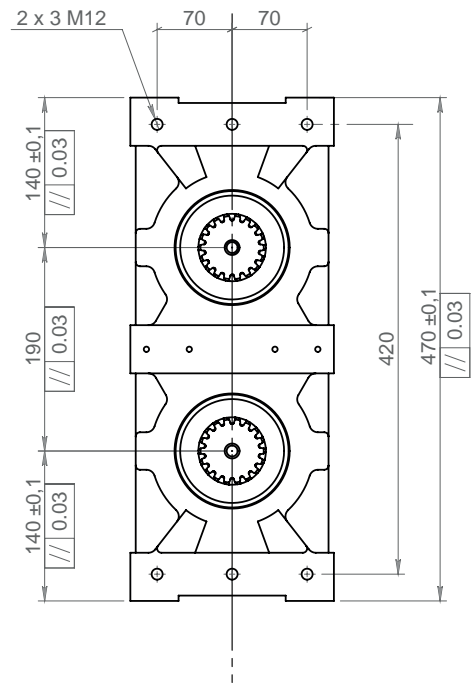
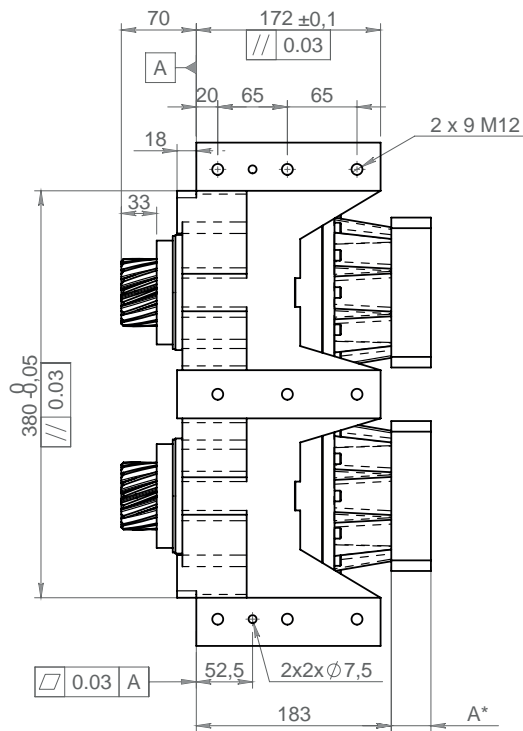
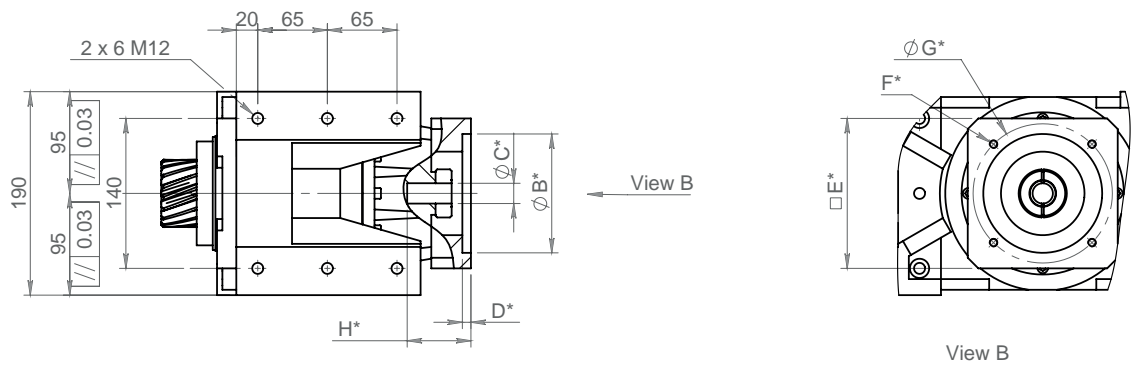

	IFA 100 11/19	IFA 140 11/19	IFA 140 22/32	IFA200 22/32
A	27	27	37	42
E	100	140	140	200
H	49	49	59	64

*B C D F G According to motor dimensions
Tapping depth = 1.5x0 thread

DIMENSIONS - TYPE R

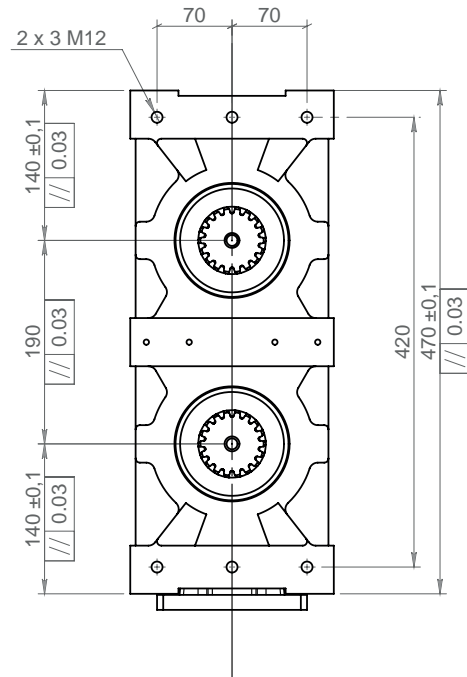
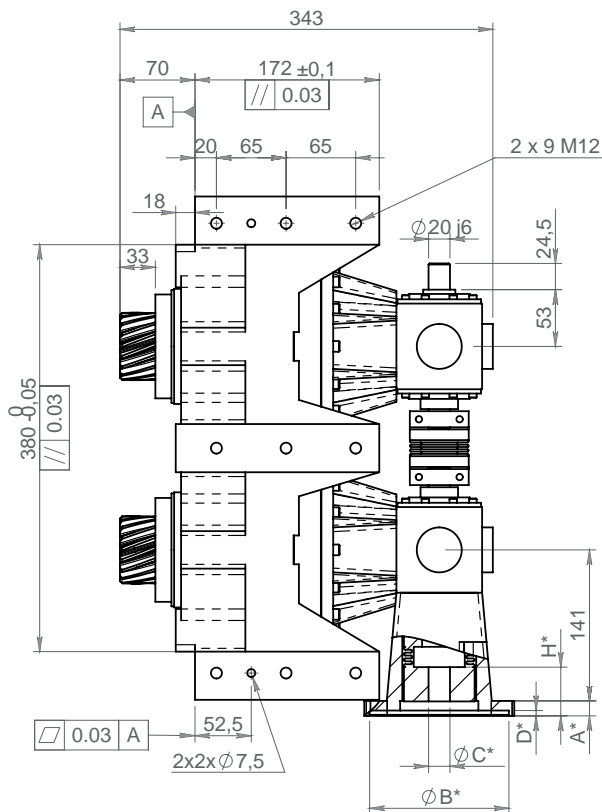
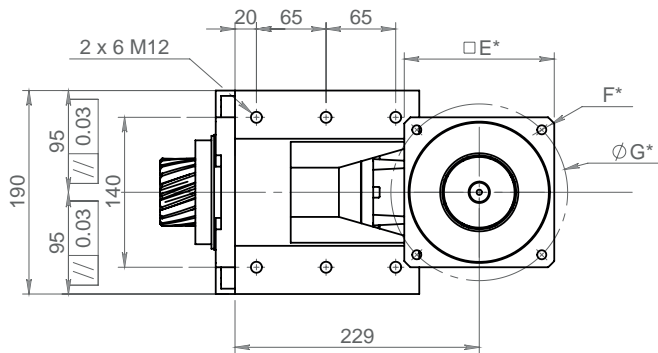

	MF1 100	MF1 140	MF1 200
A	14	14	18
E	100	140	200
H	62	62	66

*B C D F G According to motor dimensions
Tapping depth = 1.5x0 thread

Dimensions and main data for information only - Please consult us and / or refer to Products Datasheets
For accurate selection, contact your local supplier

DRP *SIZE 2*



DRP2

Weight

Efficiency

Backlash

Color

Tooth type

Module

Helix angle (left)

Number of teeth

Pressure angle

Theoretical pitch diameter

Addendum modification factor

Pinion quality grade

Surface hardness

Ratio

Nominal feed force

Peak acceleration feed force

Max. acceleration feed force

E-stop force

Max. linear speed

Nominal linear speed

Linear stiffness on the rack

Inertia

Ratio

Nominal output torque

Max. output torque

No load torque

No load torque

E-stop torque

Max. input speed

Nominal input speed

Radial stiffness

Axial stiffness

Torsional stiffness

General data

			M	R
m	kg	1 Stage		
		2 Stages	202	207
η	%	1 Stage		
		2 Stages	93	91
J	arcmin	Standard	3	4
		Reduced	1	2
RAL2012				

Pinion features

		Helical	Straight
Mo	mm	4	4
β	deg	19°31'42"	0°
Z2	-	18	19
α	deg	20°	20°
D02	mm	76,39	76
x0	-	0,638	0,688
Q	(ISO 1328)	6	6
HRC	HRC	61-63	61-63

Rack features

Version			Helical	Straight
Standard	F2B	N	28552	24705
	F2NOT	N	57103	42966
	Material		C45E DIN 1.1191	
Reinforced	F2B	N	35138	N/A
	F2NOT	N	76388	N/A
	Material		16MnCr5	
Available length	L	mm	500, 1000, 2000	
Dimensions	see details p113-115			

Drive linear features

		5	7	10	17	21	31	46	61	91
F2N	N				27491	20945	31418	20945	30109	20945
F2B	N				48121	36654	54981	36654	52703	36654
F2B_max	N				96243	73308	109962	73308	73308	73308
F2NOT	N				71999	71999	71999	71999	71999	71999
V2B	m/min				85	69	46	31	24	16
V2N	m/min				30	24	16	11	8	6
K2T +M	N/μm				291	276	291	278	288	275
K2T +R	N/μm					251	273	273	265	275
I +M	kg.mm ²				816	722	663	634	596	588
I +R	kg.mm ²					1313	1254	1226	1188	1160

DRP ratings

		5	7	10	17	21	31	46	61	91
T2N	Nm				1050	800	1200	800	1150	800
T2B	Nm				1838	1400	2100	1400	2013	1400
T01 +R	Nm					2,3	2,3	2,3	2,3	2,3
T01 +M	Nm				2	2	2	2	2	2
T2NOT	Nm				2750	2750	2750	2750	2750	2750
n1B	rpm				6000	6000	6000	6000	6000	6000
n1N	rpm				2100	2100	2100	2100	2100	2100
K2R	N/μm				650	650	650	650	650	650
K2A	N/μm				2162	2162	2162	2162	2162	2162
C2t +R	Nm/ rad				-	677236	794120	794120	866312	804433
	Nm/arcmin					197	231	231	252	234
C2t +M	Nm/ rad				904127	814746	904127	825059	883501	807870
	Nm/arcmin				263	237	263	240	257	235

Dimensions and main data for information only - Please consult us and / or refer to Products Datasheets
 For accurate selection, contact your local supplier

DIMENSIONS - TYPE M

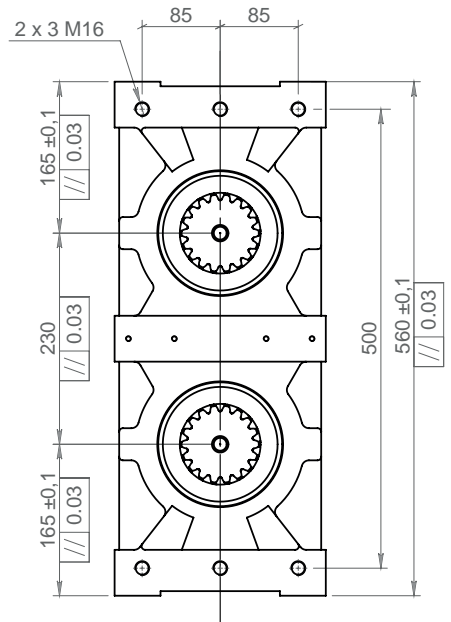
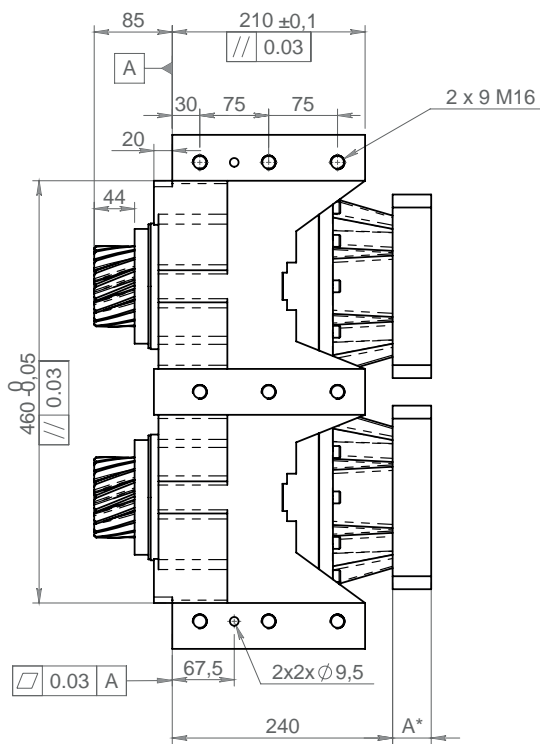
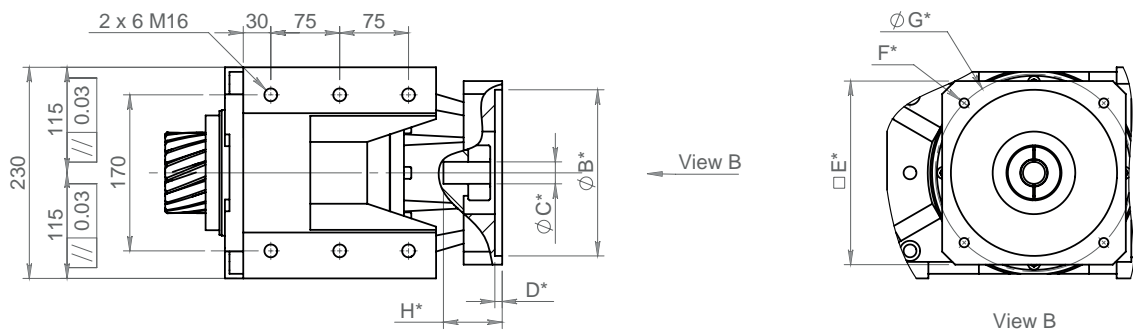

	IFB 140 14/24	IFB 140 28/38	IFB 200 28/38	IFB 260 28/38
A	37	42	57	64
E	140	140	200	260
H	59	65	80	87

*B C D F G According to motor dimensions
Tapping depth = 1.5x0 thread

DIMENSIONS - TYPE R

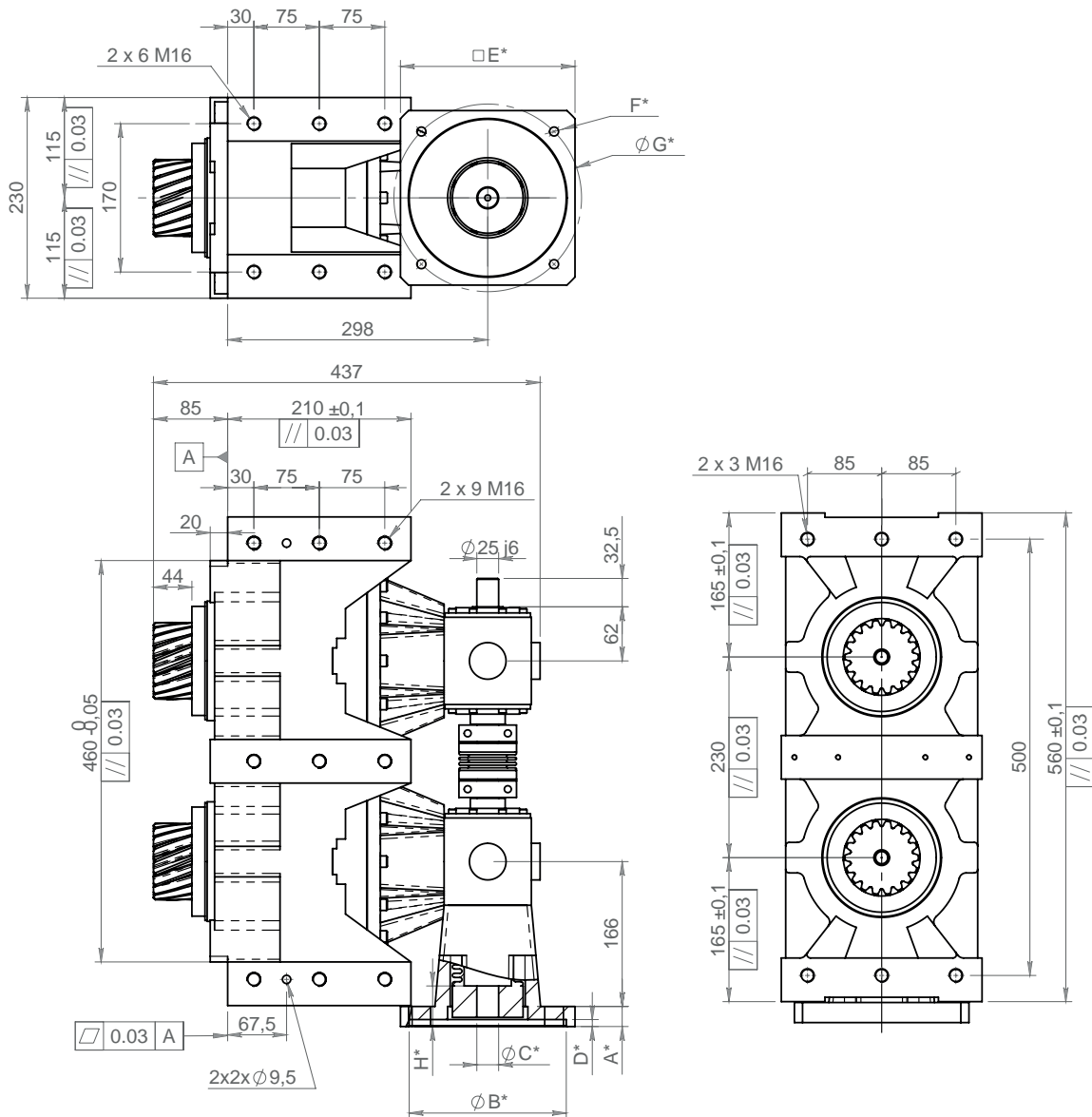

	MF2 140	MF2 200
A	23	23
E	140	200
H	80	80

*B C D F G According to motor dimensions
Tapping depth = 1.5x0 thread

Dimensions and main data for information only - Please consult us and / or refer to Products Datasheets
For accurate selection, contact your local supplier

DRP SIZE 3



DRP3

Weight

Efficiency

Backlash

Color

Tooth type

Module

Helix angle (left)

Number of teeth

Pressure angle

Theoretical pitch diameter

Addendum modification factor

Pinion quality grade

Surface hardness

Ratio

Nominal feed force

Peak acceleration feed force

Max. acceleration feed force

E-stop force

Max. linear speed

Nominal linear speed

Linear stiffness on the rack

Inertia

Ratio

Nominal output torque

Max. output torque

No load torque

No load torque

E-stop torque

Max. input speed

Nominal input speed

Radial stiffness

Axial stiffness

Torsional stiffness

General data

			M	R
m	kg	1 Stage		
		2 Stages	294	300
η	%	1 Stage		
		2 Stages	93	91
J	arcmin	Standard	3	4
		Reduced	1	2
RAL2012				

Pinion features

		Helical	Straight
Mo	mm	5	5
β	deg	19°31'42"	0°
Z2	-	18	19
α	deg	20°	20°
D02	mm	95,49	95
x0	-	0,251	0,300
Q	(ISO 1328)	6	6
HRC	HRC	61-63	61-63

Rack features

Version			Helical	Straight
Standard	F2B	N	44837	38761
	F2NOT	N	89674	67410
	Material		C45E DIN 1.1191	
Reinforced	F2B	N	55062	N/A
	F2NOT	N	119700	N/A
	Material		16MnCr5	
Available length	L	mm	500, 1000, 2000	
Dimensions	see details p113-115			

Drive linear features

		5	7	10	17	21	31	46	61	91
F2N	N				38748	31417	46078	29532	32255	32255
F2B	N				67861	54980	80637	51691	56446	56446
F2B_max	N				135721	109959	161273	103383	112891	112891
F2NOT	N				103676	103676	103676	103676	103676	103676
V2B	m/min				88	71	48	33	25	16
V2N	m/min				28	23	15	10	8	5
K2T +M	N/μm				437	426	409	399	387	421
K2T +R	N/μm					363	368	374	385	382
I +M	kg.mm ²				1242	994	846	773	666	647
I +R	kg.mm ²					2527	2378	2305	2199	2180

DRP ratings

		5	7	10	17	21	31	46	61	91
T2N	Nm				1850	1500	2200	1410	1540	1540
T2B	Nm				3240	2625	3850	2468	2695	2695
T01 +R	Nm					2,8	2,8	2,8	2,8	2,8
T01 +M	Nm				2.5	2,5	2,5	2,5	2,5	2,5
T2NOT	Nm				4950	4950	4950	4950	4950	4950
n1B	rpm				5000	5000	5000	5000	5000	5000
n1N	rpm				1600	1600	1600	1600	1600	1600
K2R	N/μm				1100	1100	1100	1100	1100	1100
K2A	N/μm				4355	4355	4355	4355	4355	4355
C2t +R	Nm/ rad					1354472	1505733	1423227	1498858	1478231
	Nm/arcmin					394	438	414	436	430
C2t +M	Nm/ rad				1873572	1787628	1663869	1588239	1512609	1753251
	Nm/arcmin				545	520	484	462	440	510

Dimensions and main data for information only - Please consult us and / or refer to Products Datasheets
 For accurate selection, contact your local supplier

DIMENSIONS - TYPE M

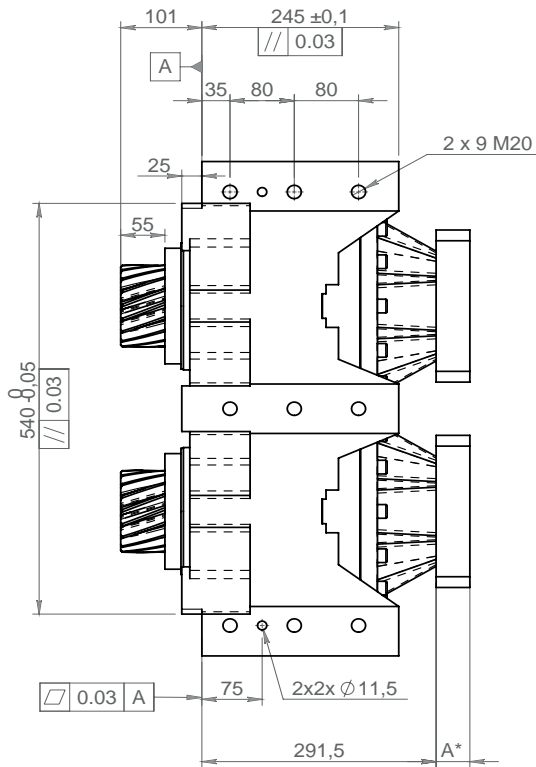
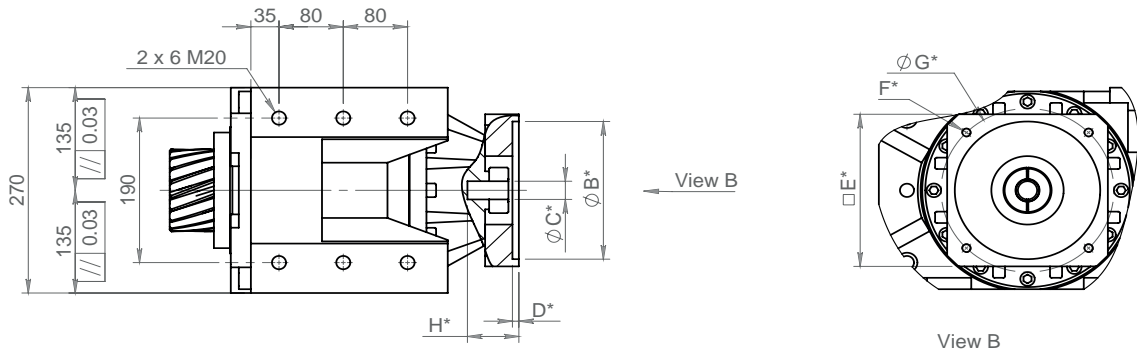

	IFB 140 14/24	IFB 140 28/38	IFB 200 28/38	IFB 260 28/38
A	37	42	57	64
E	140	140	200	260
H	59	65	80	87

*B C D F G According to motor dimensions
Tapping depth = 1.5x0 thread

DIMENSIONS - TYPE R

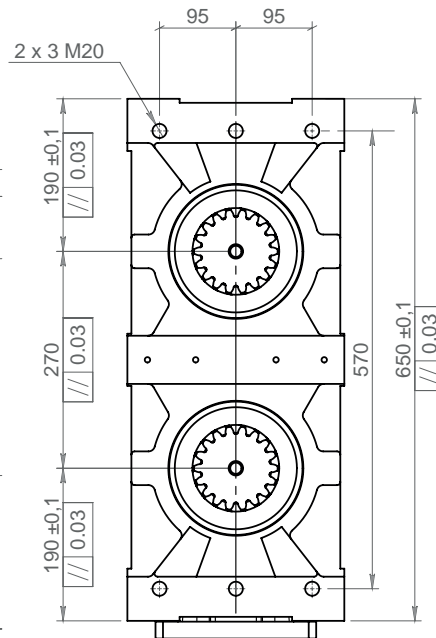
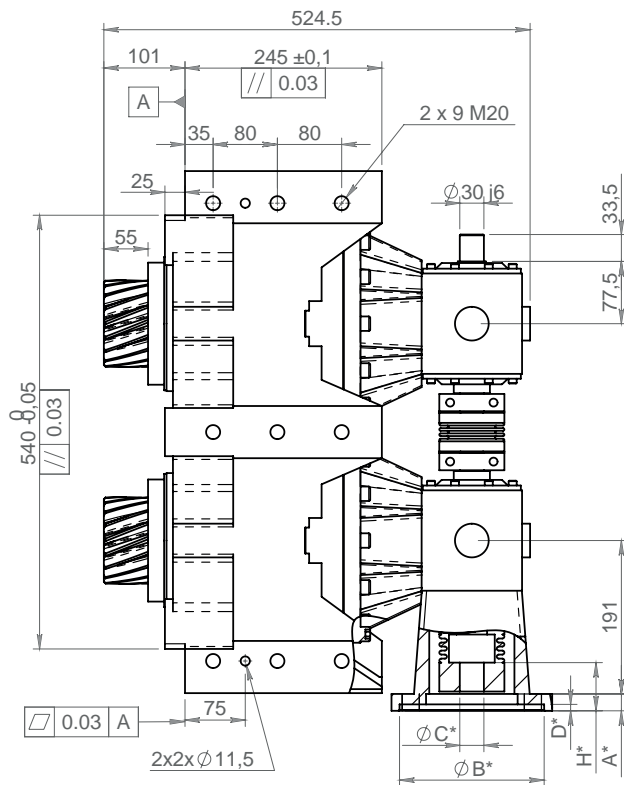
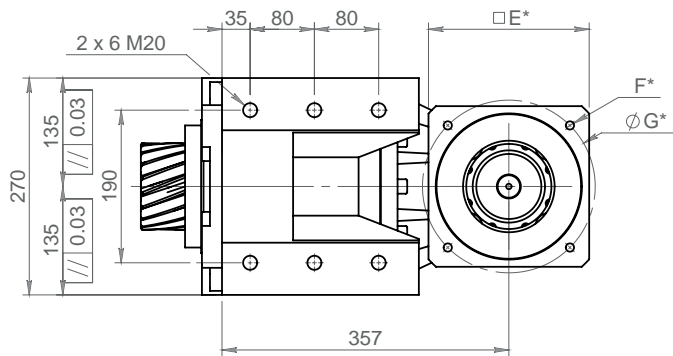

	MF3 140	MF3 200	MF3 260
A	21	21	24
E	140	200	260
H	80	80	83

*B C D F G According to motor dimensions
Tapping depth = 1.5x0 thread

Dimensions and main data for information only - Please consult us and / or refer to Products Datasheets
For accurate selection, contact your local supplier

DRP SIZE 4



DRP4

Weight

Efficiency

Backlash

Color

Tooth type

Module

Helix angle (left)

Number of teeth

Pressure angle

Theoretical pitch diameter

Addendum modification factor

Pinion quality grade

Surface hardness

Ratio

Nominal feed force

Peak acceleration feed force

Max. acceleration feed force

E-stop force

Max. linear speed

Nominal linear speed

Linear stiffness on the rack

Inertia

Ratio

Nominal output torque

Max. output torque

No load torque

No load torque

E-stop torque

Max. input speed

Nominal input speed

Radial stiffness

Axial stiffness

Torsional stiffness

General data

			M	R
m	kg	1 Stage		
		2 Stages	506	520
η	%	1 Stage		
		2 Stages	93	91
J	arcmin	Standard	3	4
		Reduced	1	2
RAL2012				

Pinion features

		Helical	Straight
Mo	mm	6	6
β	deg	19°31'42"	0°
Z2	-	18	19
α	deg	20°	20°
D02	mm	114,59	114
x0	-	0,201	0,250
Q	(ISO 1328)	6	6
HRC	HRC	61-63	61-63

Rack features

Version			Helical	Straight
Standard	F2B	N	64103	55424
	F2NOT	N	128205	96390
	Material		C45E DIN 1.1191	
Reinforced	F2B	N	78753	N/A
	F2NOT	N	171203	N/A
	Material		16MnCr5	
Available length	L	mm	500, 1000, 2000	
Dimensions	see details p113-115			

Drive linear features

		5	7	10	17	21	31	46	61	91
F2N	N				61087	61087	62833	44681	49568	49568
F2B	N				106903	106903	109957	78192	86744	86744
F2B_max	N				213806	213806	219914	156384	173488	173488
F2NOT	N				132647	132647	132647	132647	132647	132647
V2B	m/min				85	69	46	31	24	16
V2N	m/min				28	22	15	10	8	5
K2T +M	N/μm				461	461	461	440	493	440
K2T +R	N/μm					440	440	420	437	431
I +M	kg.mm ²				3439	2246	1886	1702	1146	1095
I +R	kg.mm ²					10765	7955	7770	7242	7191

DRP ratings

		5	7	10	17	21	31	46	61	91
T2N	Nm				3500	3500	3600	2560	2840	2840
T2B	Nm				6125	6125	6300	4480	4970	4970
T01 +R	Nm					3,6	3,6	3,6	3,6	3,6
T01 +M	Nm				3	3	3	3	3	3
T2NOT	Nm				7600	7600	7600	7600	7600	7600
n1B	rpm				4000	4000	4000	4000	4000	4000
n1N	rpm				1300	1300	1300	1300	1300	1300
K2R	N/μm				1250	1250	1250	1250	1250	1250
K2A	N/μm				5000	5000	5000	5000	5000	5000
C2t +R	Nm/ rad					2475178	2471740	2289539	2444238	2382359
	Nm/arcmin					720	719	666	711	693
C2t +M	Nm/ rad				2681442	2681442	2681442	2468302	3025217	2471740
	Nm/arcmin				780	780	780	718	880	719

Dimensions and main data for information only - Please consult us and / or refer to Products Datasheets
For accurate selection, contact your local supplier

DIMENSIONS - TYPE M

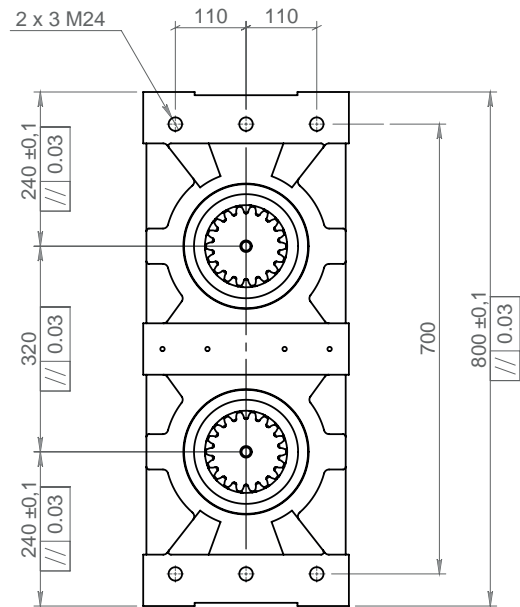
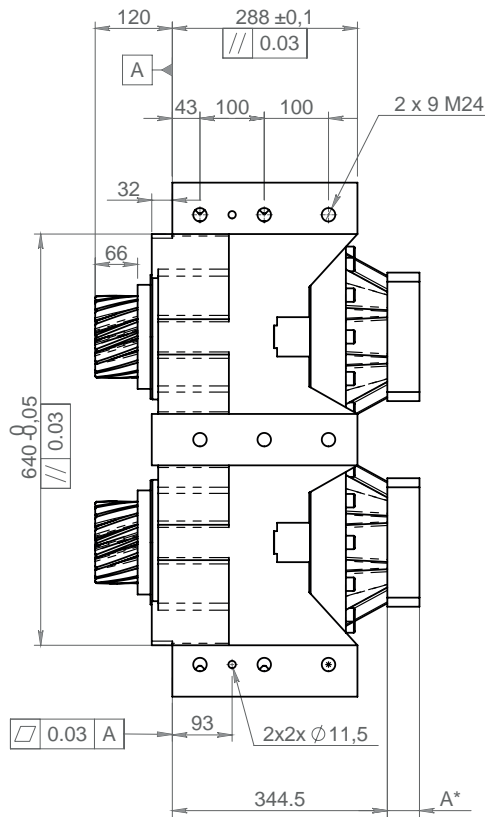
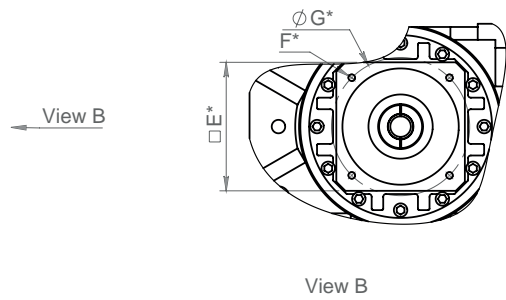
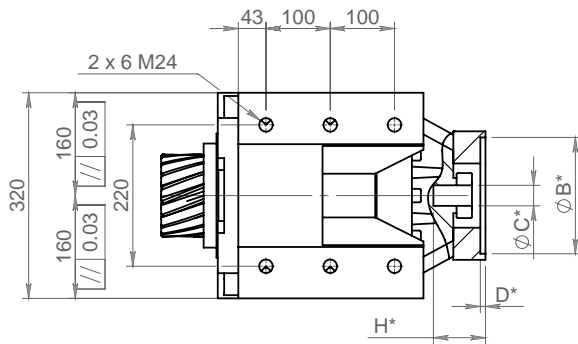

	IFC 140 22/32	IFC 200 22/48	IFC 260 35/48
A	42	50	51
E	140	200	260
H	73	81	82

*B C D F G According to motor dimensions
Tapping depth = 1.5x0 thread

DIMENSIONS - TYPE R

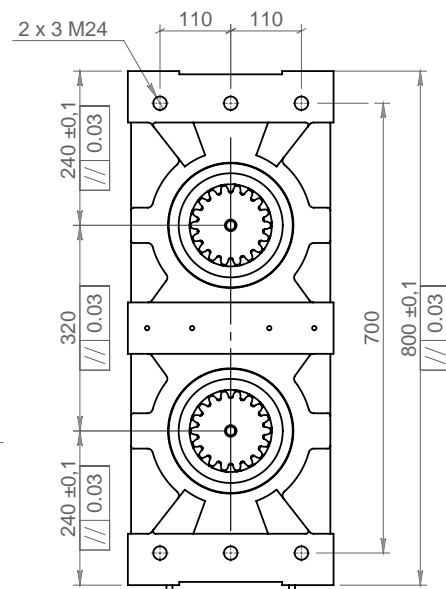
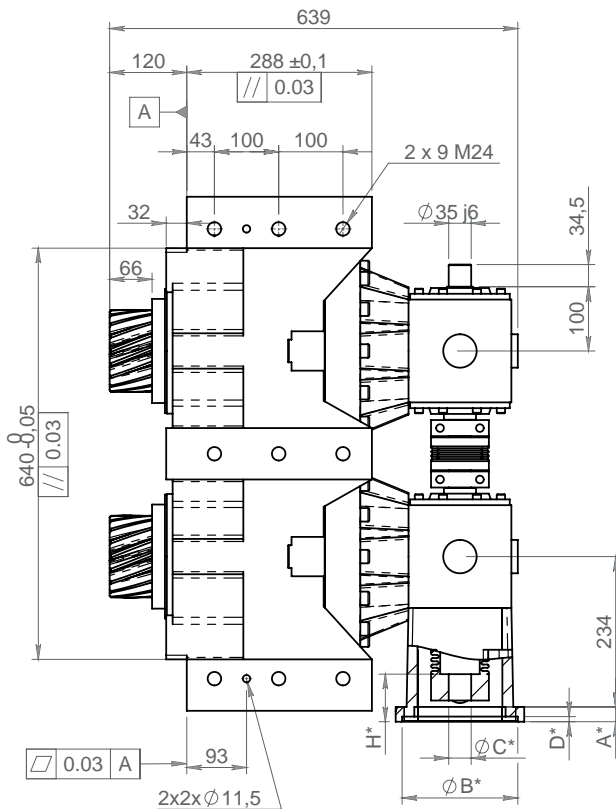
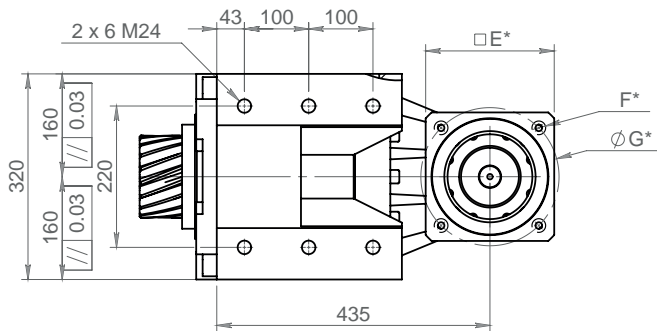

	MF4 200	MF4 260
A	23	23
E	200	260
H	110	110

*B C D F G According to motor dimensions
Tapping depth = 1.5x0 thread

Dimensions and main data for information only - Please consult us and / or refer to Products Datasheets
For accurate selection, contact your local supplier

DRP *SIZE 5*



DRP5

Weight

Efficiency

Backlash

Color

Tooth type

Module

Helix angle (left)

Number of teeth

Pressure angle

Theoretical pitch diameter

Addendum modification factor

Pinion quality grade

Surface hardness

Ratio

Nominal feed force

Peak acceleration feed force

Max. acceleration feed force

E-stop force

Max. linear speed

Nominal linear speed

Linear stiffness on the rack

Inertia

Ratio

Nominal output torque

Max. output torque

No load torque

No load torque

E-stop torque

Max. input speed

Nominal input speed

Radial stiffness

Axial stiffness

Torsional stiffness

General data

			M	R
m	kg	1 Stage		
		2 Stages	1091	1116
η	%	1 Stage		
		2 Stages	93	91
J	arcmin	Standard	3	4
		Reduced	1	2
RAL2012				

Pinion features

		Helical	Straight
Mo	mm	8	8
β	deg	19°31'42"	0
Z2	-	15	16
α	deg	20°	20°
D02	mm	127,32	128
x0	-	0,355	0,313
Q	(ISO 1328)	6	6
HRC	HRC	61-63	61-63

Rack features

Version			Helical	Straight
Standard	F2B	N	114380	91220
	F2NOT	N	174205	148960
	Material		C45E DIN 1.1191	
Reinforced	F2B	N	N/A	N/A
	F2NOT	N	N/A	N/A
	Material		16MnCr5	
Available length	L	mm	500, 1000, 2000	
Dimensions			see details p113-115	

Drive linear features

		5	7	10	17	21	31	46	61	91
F2N	N					73830	105247	86396	86396	86396
F2B	N					118128	157870	138234	138234	138234
F2B_max	N					236255	315740	276469	276469	276469
F2NOT	N					180647	180647	180647	180647	180647
V2B	m/min					76	52	35	26	18
V2N	m/min					19	13	9	7	4
K2T +M	N/μm					623	623	545	598	500
K2T +R	N/μm					623	622	545	595	483
I +M	kg.mm ²					2916	2204	1851	1228	1133
I +R	kg.mm ²					17436	16724	16371	15760	15666

DRP ratings

		5	7	10	17	21	31	46	61	91
T2N	Nm					4700	6700	5500	5500	5500
T2B	Nm					7520	10050	8800	8800	8800
T01 +R	Nm					5,2	5,2	5,2	5,2	5,2
T01 +M	Nm					4	4	4	4	4
T2NOT	Nm					11500	11500	11500	11500	11500
n1B	rpm					4000	4000	4000	4000	4000
n1N	rpm					1000	1000	1000	1000	1000
K2R	N/μm					1550	1550	1550	1550	1550
K2A	N/μm					5484	5484	5484	5484	5484
C2t +R	Nm/ rad					4812845	4802532	3781521	4427818	3107723
	Nm/arcmin					1400	1397	1100	1288	904
C2t +M	Nm/ rad					4812845	4812845	3781521	4469071	3279610
	Nm/arcmin					1400	1400	1100	1300	954

Dimensions and main data for information only - Please consult us and / or refer to Products Datasheets
 For accurate selection, contact your local supplier

DIMENSIONS - TYPE M

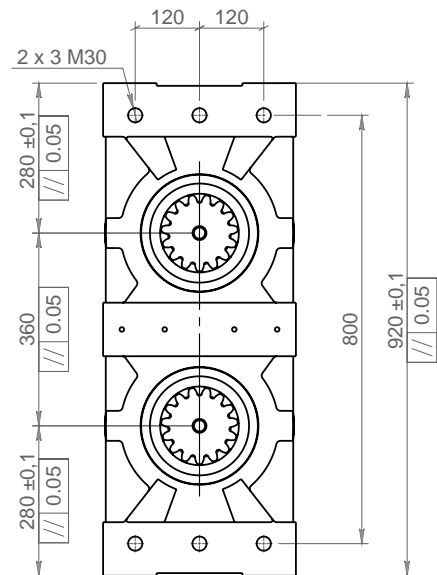
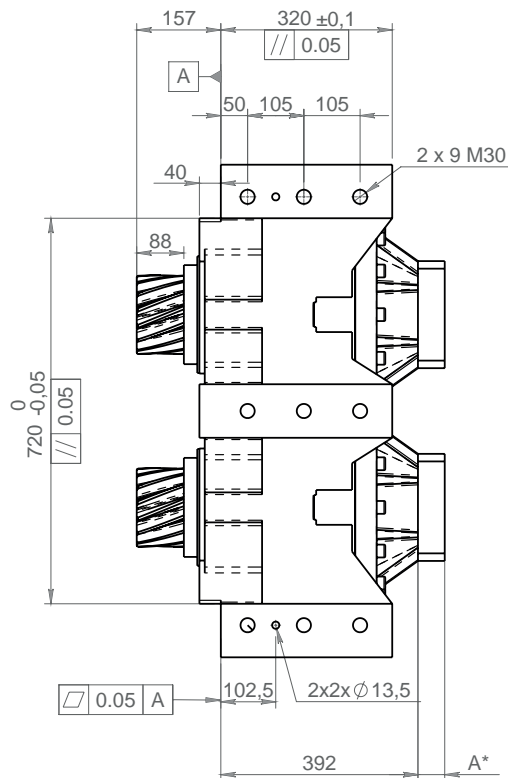
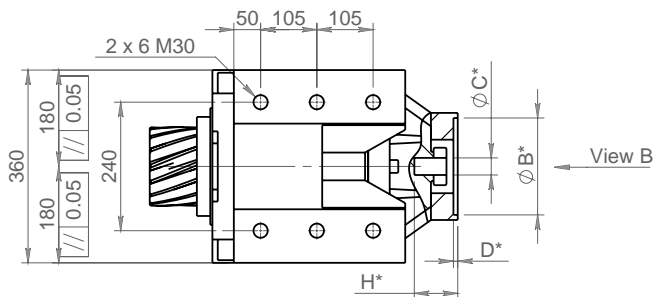

	IFC 140 22/32	IFC 200 22/48	IFC 260 35/48
A	42	50	51
E	140	200	260
H	73	81	82

*B C D F G According to motor dimensions
Tapping depth = 1.5x0 thread

DIMENSIONS - TYPE R

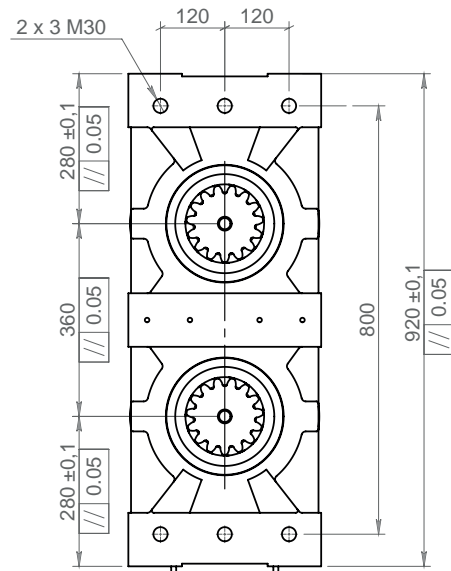
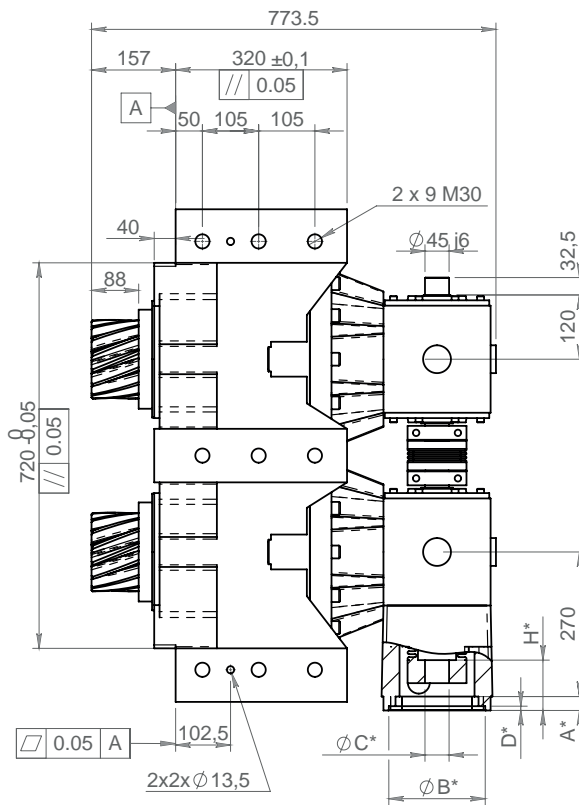
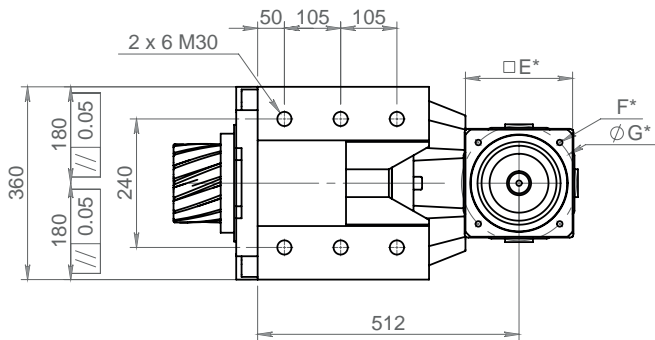

	MF5 200	MF5 260
A	26	26
E	200	260
H	110	110

*B C D F G According to motor dimensions
Tapping depth = 1.5x0 thread

Dimensions and main data for information only - Please consult us and / or refer to Products Datasheets
For accurate selection, contact your local supplier