

2 Speed Spindle Gearboxes

MSR

MSR *SIZE 330*



PERFORMANCES

Unit codification
High speed ratio
Low speed ratio
Ratio code
Nominal output torque (S1-100%)
Maximum input speed
Inertia @ input (high speed ratio)
Inertia @ input (low speed ratio)
Efficiency at rated input speed
Weight
Max radial load output (@131rpm output, in the middle of the shaft)

PERFORMANCES

Unit codification
High speed ratio
Low speed ratio
Ratio code
Nominal output torque (S1-100%)
Maximum input speed
Inertia @ input (high speed ratio)
Inertia @ input (low speed ratio)
Efficiency at rated input speed
Weight
Max radial load output (@131rpm output, in the middle of the shaft)

Paint RAL 2002 & RAL 7016

Speed changer: voltage 24V DC,
switching current 200mA at 70°C, cable length 5m

Key ways following NFE 22.175

Motor must follow DIN 42955 class R

Oil inlet interface

Oil flow rate (input pressure)

Oil outlet interface

Technical Features

MSR 334		
i1		2.00
i2		9.88
i		2010
T2N	[Nm]	2500
N1B	[rpm]	6000
J1h	[Kg.mm ²]	56000
J1l	[Kg.mm ²]	10000
η	%	94
m	[kg]	280
Fr	[N]	30000

Technical Features

MSR 336		
i1		2.00
i2		7.66
i		2076
T2N	[Nm]	2500
N1B	[rpm]	6000
J1h	[Kg.mm ²]	51000
J1l	[Kg.mm ²]	13000
η	%	94
m	[kg]	276
Fr	[N]	30000

Additional Features

Oi		1/2"G
Of	[l/min]	9 (1,5 - 6 bars)
Oo		Tube 42mm

DIMENSIONS

INPUT - TYPE A/F
OUTPUT - TYPE D

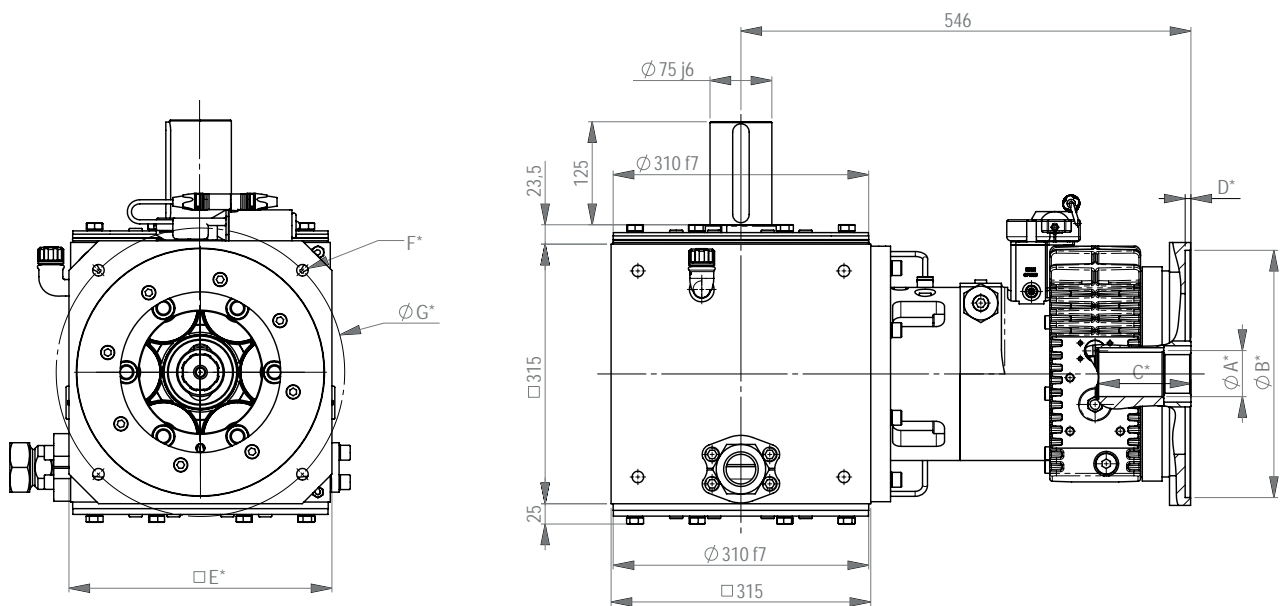
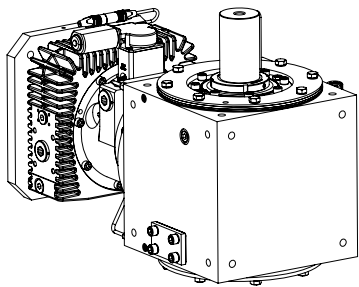

* A B C D E F G According to motor dimensions

DIMENSIONS

INPUT - TYPE A/F
OUTPUT - TYPE H

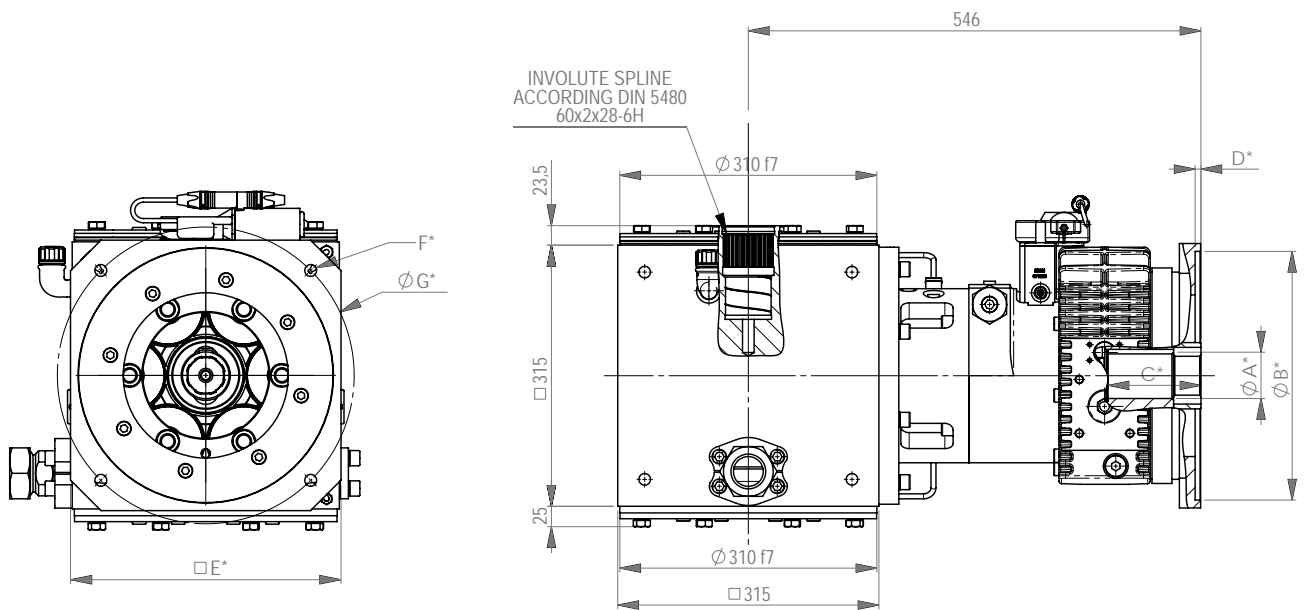
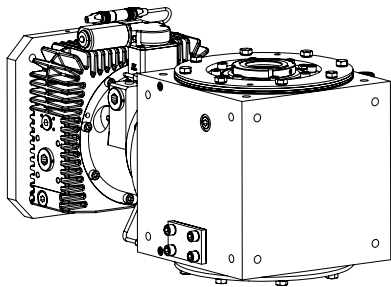

* A B C D E F G According to motor dimensions

MSR *SIZE 640*



PERFORMANCES

Unit codification

High speed ratio

Low speed ratio

Ratio code

Nominal output torque (S1-100%)

Maximum input speed

Inertia @ input (high speed ratio)

Inertia @ input (low speed ratio)

Efficiency at rated input speed

Weight

Max radial load output
(@131rpm output, in the middle of the shaft)

PERFORMANCES

Unit codification

High speed ratio

Low speed ratio

Ratio code

Nominal output torque (S1-100%)

Maximum input speed

Inertia @ input (high speed ratio)

Inertia @ input (low speed ratio)

Efficiency at rated input speed

Weight

Max radial load output
(@131rpm output, in the middle of the shaft)

Paint RAL 2002 & RAL 7016

Speed changer: voltage 24V DC,
switching current 200mA at 70°C, cable length 5m

Key ways following NFE 22.175

Motor must follow DIN 42955 class R

Oil inlet interface

Oil flow rate (input pressure)

Oil outlet interface

Technical Features

			MSR 644
i1			2.00
i2			9.88
i			2010
T2N	[Nm]		5900
N1B	[rpm]		5000
J1h	[Kg.mm²]		122000
J1l	[Kg.mm²]		34000
η	%		94
m	[kg]		548
Fr	[N]		50000

Technical Features

			MSR 646	
i1			2.00	3.00
i2			7.66	11.49
i			2076	3012
T2N	[Nm]		7000	7000
N1B	[rpm]		5000	5000
J1h	[Kg.mm²]		132000	98000
J1l	[Kg.mm²]		48000	45000
η	%		94	94
m	[kg]		548	548
Fr	[N]		50000	50000

Additional Features

Oi		1"G
Of	[l/min]	17 (1,5 - 6 bars)
Oo		Tube 42mm

DIMENSIONS

INPUT - TYPE A/F
OUTPUT - TYPE D

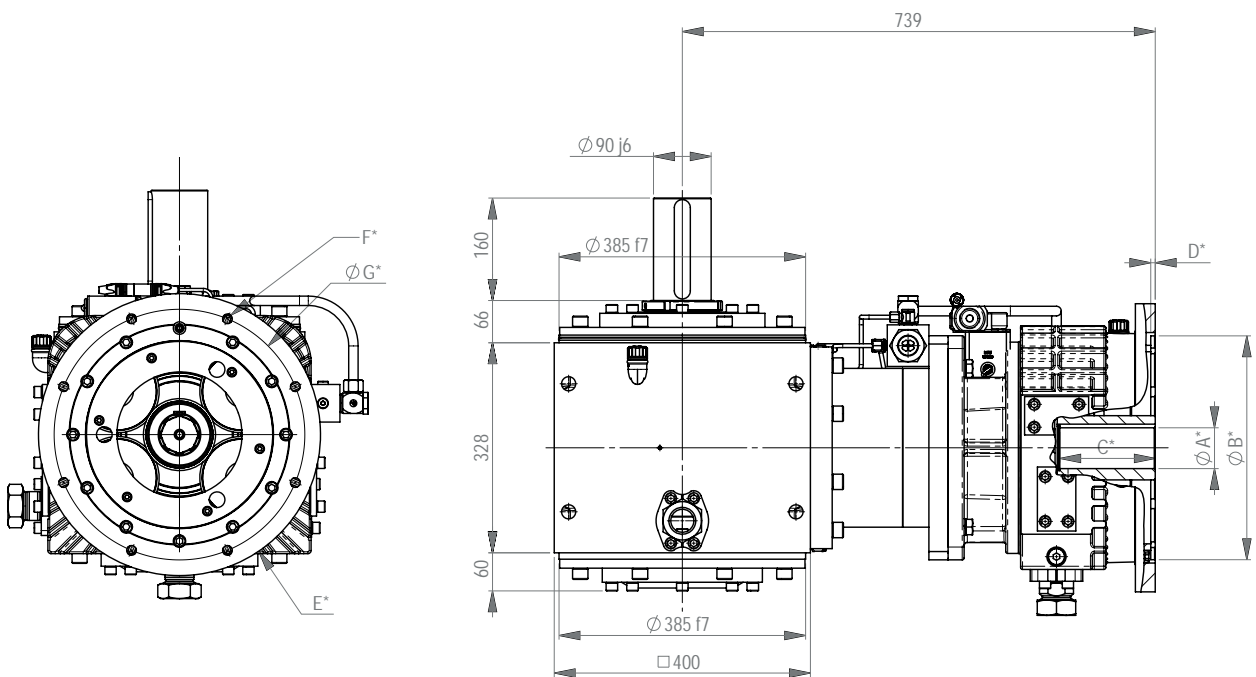
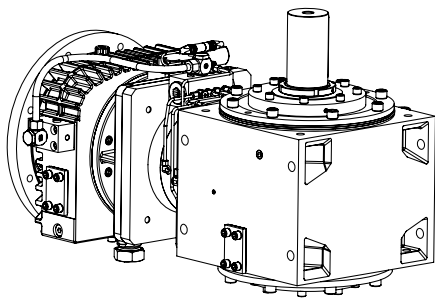

* A B C D E F G According to motor dimensions

DIMENSIONS

INPUT - TYPE A/F
OUTPUT - TYPE H

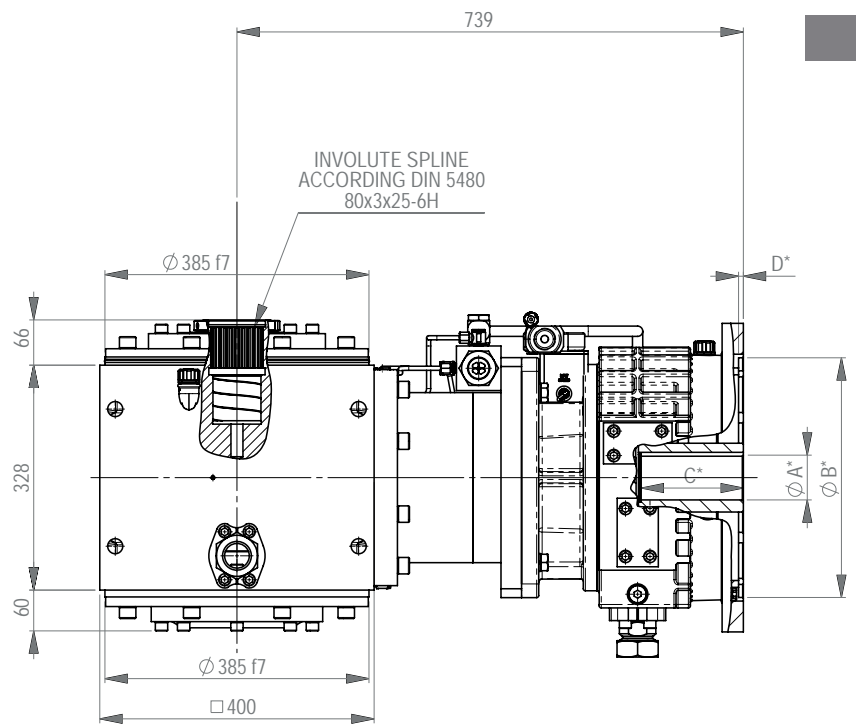
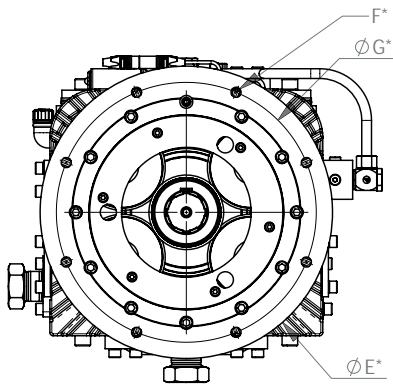
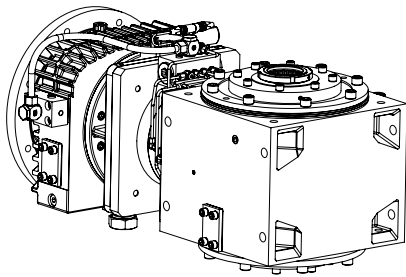

* A B C D E F G According to motor dimensions

MSR *SIZE 650*



PERFORMANCES

Unit codification

High speed ratio

Low speed ratio

Ratio code

Nominal output torque (S1-100%)

Maximum input speed

Inertia @ input (high speed ratio)

Inertia @ input (low speed ratio)

Efficiency at rated input speed

Weight

Max radial load output
(@131rpm output, in the middle of the shaft)

PERFORMANCES

Unit codification

High speed ratio

Low speed ratio

Ratio code

Nominal output torque (S1-100%)

Maximum input speed

Inertia @ input (high speed ratio)

Inertia @ input (low speed ratio)

Efficiency at rated input speed

Weight

Max radial load output
(@131rpm output, in the middle of the shaft)

Paint RAL 2002 & RAL 7016

Speed changer: voltage 24V DC,
switching current 200mA at 70°C, cable length 5m

Key ways following NFE 22.175

Motor must follow DIN 42955 class R

Oil inlet interface

Oil flow rate (input pressure)

Oil outlet interface

Technical Features

MSR 654		
i1		2.26
i2		11.16
i		2211
T2N	[Nm]	6600
N1B	[rpm]	4500
J1h	[Kg.mm²]	307000
J1l	[Kg.mm²]	44000
η	%	94
m	[kg]	750
Fr	[N]	75000

Technical Features

MSR 656		
i1		2.26
i2		8.66
i		2286
T2N	[Nm]	9000
N1B	[rpm]	4500
J1h	[Kg.mm²]	317000
J1l	[Kg.mm²]	60000
η	%	94
m	[kg]	750
Fr	[N]	75000

Additional Features

Oi		1"G
Of	L/min	18 (1,5 - 6 bars)
Oo		Tube 42mm

DIMENSIONS

INPUT - TYPE A/F
OUTPUT - TYPE D

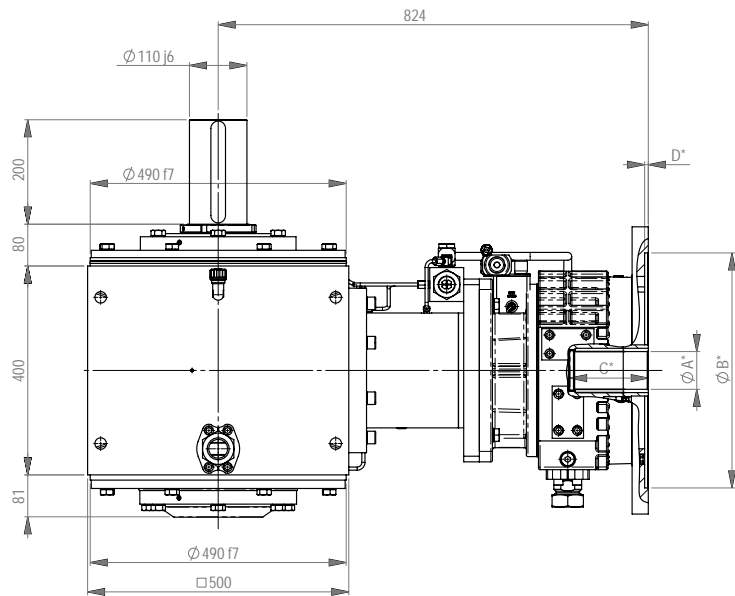
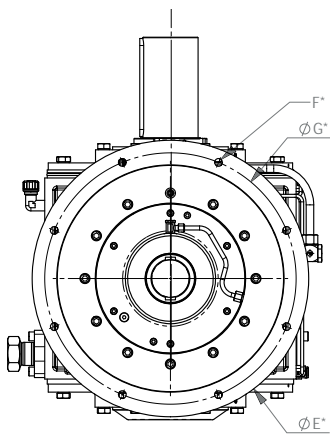
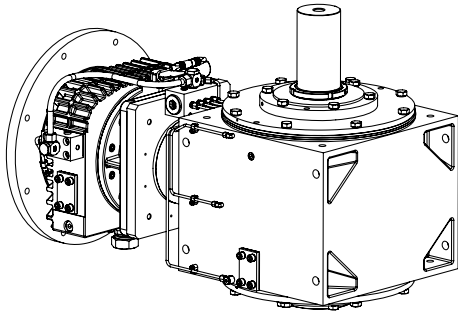

* A B C D E F G According to motor dimensions

DIMENSIONS

INPUT - TYPE A/F
OUTPUT - TYPE H

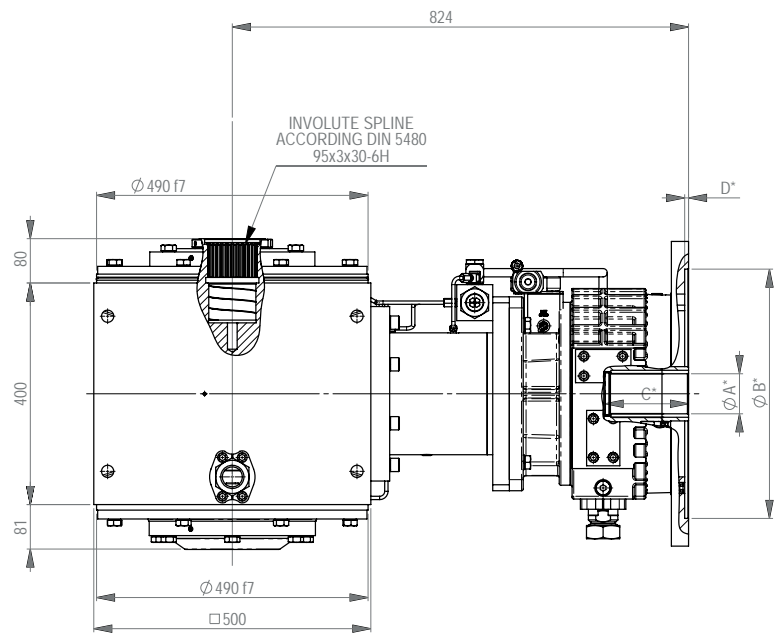
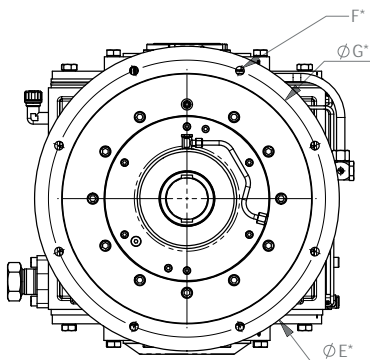
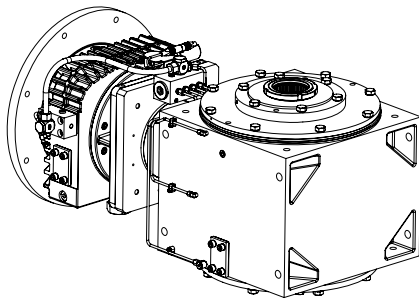

* A B C D E F G According to motor dimensions

MSR *SIZE 660*



PERFORMANCES

Unit codification

High speed ratio

Low speed ratio

Ratio code

Nominal output torque (S1-100%)

Maximum input speed

Inertia @ input (high speed ratio)

Inertia @ input (low speed ratio)

Efficiency at rated input speed

Weight

Max radial load output
(@131rpm output, in the middle of the shaft)

Paint RAL 2002 & RAL 7016

Speed changer: voltage 24V DC,
switching current 200mA at 70°C, cable length 5m

Key ways following NFE 22.175

Motor must follow DIN 42955 class R

Oil inlet interface

Oil flow rate (input pressure)

Oil outlet interface

Technical Features

			MSR 666
i1			3.00
i2			11.49
i			3012
T2N	[Nm]		12000
N1B	[rpm]		3500
J1h	[Kg.mm²]		480000
J1l	[Kg.mm²]		69000
η	%		94
m	[kg]		1400
Fr	[N]		85000

Additional Features

Oi			1"G
Of	[l/min]		19 (1,5 - 6 bars)
Oo			Tube 42mm

DIMENSIONS

INPUT - TYPE A/F
OUTPUT - TYPE D

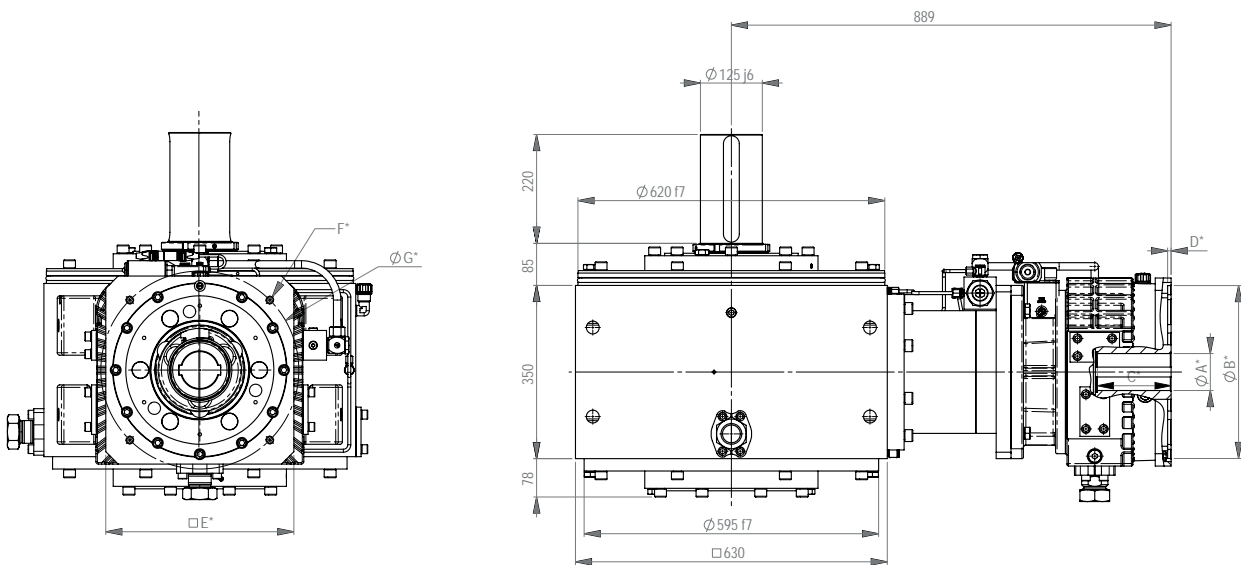
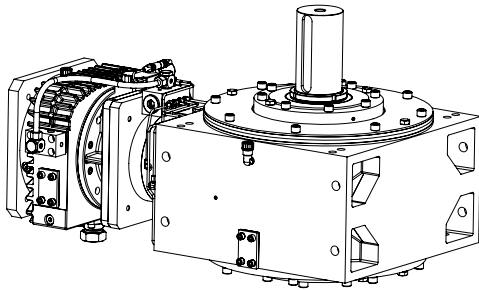

* A B C D E F G According to motor dimensions

ANDANTEX USA Inc.

1705 Valley Road,
Wanamassa, NJ 07712
800-713-6170
Fax 732-493-2949
E-mail info@andantex.com
WWW.ANDANTEX.COM