

**FALK**



# FALK CT-SERIES GEAR DRIVES

TYPE CTA



**RegalRexnord**

# A Trusted Name for Cooling Towers



The Falk® Type CTA Gear Drives, brought to you by the makers of Addax® Composite Couplings, are specifically designed to directly replace Amarillo® and Marley® M Series gearboxes\* for cooling tower and vertical drive applications. The critical mounting dimensions of the type CTA matches comparable Amarillo and Marley models, allowing for quick and easy replacement of existing gearboxes.

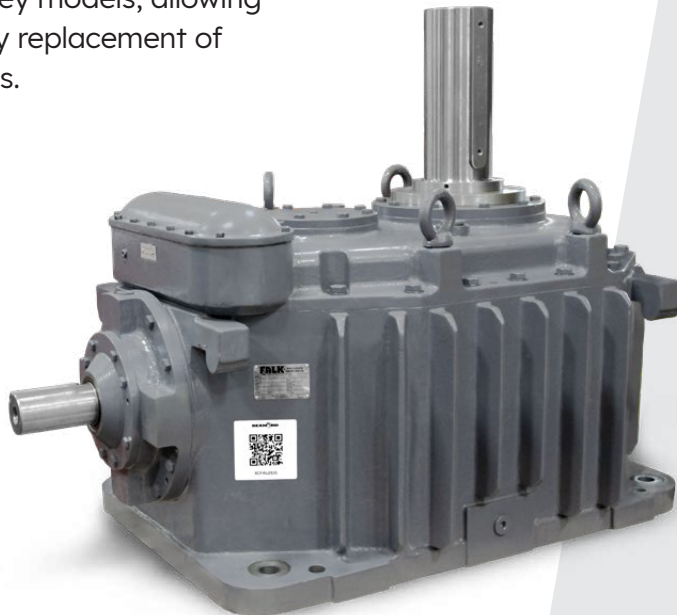

## Key Industries:

Power Generation  
Refineries  
Petrochemical  
Pulp & Paper

## Applications:

Cooling Towers  
Vertical Mixers

## Sizes:

- Four drive sizes with nineteen standard ratios from 7.5–20
- Custom ratios available upon request
- Power range of 100 HP to 390 HP at a 2.0 Service Factor

*\* Amarillo and Marley are registered trademarks of their respective owners, and are in no way associated with Regal Rexnord Corporation or any of its brands.*

# FEATURES AND BENEFITS

- Manufactured to **American Gear Manufacturers Association (AGMA)** and **Cooling Technology Institute (CTI)** standards.
- **Double reduction spiral bevel** gear units are designed for cooling tower installations and feature a tub and cover housing and **pump-less lubrication**. Oil is delivered to all requisite locations using an oil slinger in conjunction with an elaborate oil management system.
- Castings are designed and **built to absorb internal and external loads** with minimum deflection. Gear case and covers are designed to assure permanent alignment of bearings and gears under load. All casting materials are gray cast iron for effective damping of noise and vibration.
- **Tub and cover housing design** utilizes dowel pins to ensure proper alignment and is **sealed using a formed-in-place gasket material** that eliminates weeping.
- Spiral bevel gears are finished using a **state-of-the-art hard cut process**, with special software monitoring to match the profile of the mating gears.
- The housing utilizes **vertical fins to maximize thermal performance in high ambient temperatures** such as those found in cooling tower applications with no additional cooling devices required.
- **All bearings are roller-type**, and sized to meet or exceed a **minimum L<sub>10</sub> life** as specified by AGMA and CTI standards.
- **Standard marine grade paint** conforms to ISO 12944-5 guidelines for very high atmospheric corrosivity (C5 Category) to ensure long service life in the harsh cooling tower environment.
- **Optional accessories are available**, including:
  - Backstop
  - Oil level switch
  - Vibration sensor
  - RTD temperature sensors
  - Oil heater



# TYPE CTA RIGHT ANGLE

## Service Power Ratings<sup>†</sup> (Minimum Service Factor 2.0)

Input Speed RPM	Nominal Ratio	Approx LS Shaft rpm	Drive Size							
			2255		2275		2310		2350	
			HP	kW	HP	kW	HP	kW	HP	kW
1750	7.5	233	142	106	—	—	—	—	—	—
	8	219	142	106	210	157	—	—	—	—
	8.5	206	141	105	208	155	—	—	—	—
	9	194	140	104	206	154	312	233	—	—
	9.5	184	135	101	198	148	—	—	—	—
	10	175	130	97	190	142	290	216	—	—
	10.5	167	130	97	183	136	281	210	—	—
	11	159	130	97	176	131	279	208	390	291
	12	146	125	93	165	123	253	189	343	256
	12.5	140	—	—	—	—	252	188	333	248
	13	135	125	93	160	119	240	179	323	241
	14	125	120	89	155	116	231	172	310	231
	15	117	—	—	150	112	214	160	300	224
	15.5	113	—	—	—	—	208	155	294	219
	16	109	—	—	—	—	200	149	285	213
	17	103	—	—	137	102	—	—	272	203
	18	97	—	—	—	—	—	—	262	195
19	92	—	—	—	—	—	—	250	186	
20	88	—	—	—	—	—	—	241	180	
1450	7.5	233	118	88	—	—	—	—	—	—
	8	219	118	88	174	130	—	—	—	—
	8.5	206	117	87	172	128	—	—	—	—
	9	194	116	87	171	128	259	193	—	—
	9.5	184	112	84	164	122	—	—	—	—
	10	175	108	81	157	117	240	179	—	—
	10.5	167	108	81	151	113	230	172	—	—
	11	159	108	81	146	109	226	169	323	241
	12	146	104	78	137	102	212	158	284	212
	12.5	140	—	—	—	—	213	159	276	206
	13	135	104	78	133	99	201	150	268	200
	14	125	99	74	128	95	188	140	257	192
	15	117	—	—	124	92	177	132	249	186
	15.5	113	—	—	—	—	171	128	244	182
	16	109	—	—	—	—	167	125	236	176
	17	103	—	—	114	85	—	—	225	168
	18	97	—	—	—	—	—	—	217	162
19	92	—	—	—	—	—	—	207	154	
20	88	—	—	—	—	—	—	200	149	
1170	7.5	233	94	70	—	—	—	—	—	—
	8	219	94	70	139	104	—	—	—	—
	8.5	206	93	69	138	103	—	—	—	—
	9	194	93	69	137	102	207	154	—	—
	9.5	184	89	66	131	98	—	—	—	—
	10	175	86	64	126	94	190	142	—	—
	10.5	167	86	64	121	90	185	138	—	—
	11	159	86	64	117	87	179	133	259	193
	12	146	83	62	109	81	170	127	227	169
	12.5	140	—	—	—	—	169	126	220	164
	13	135	83	62	106	79	159	119	214	160
	14	125	80	60	103	77	150	112	205	153
	15	117	—	—	99	74	142	106	199	148
	15.5	113	—	—	—	—	137	102	195	145
	16	109	—	—	—	—	133	99	189	141
	17	103	—	—	91	68	—	—	180	134
	18	97	—	—	—	—	—	—	174	130
19	92	—	—	—	—	—	—	166	124	
20	88	—	—	—	—	—	—	160	119	

<sup>†</sup> Service Power Ratings are in accordance with CTI Std. 111 considering minimum 2.0 service factor (mechanical) and ambient temperature of 25°C at sea level per AGMA ISO 14179-1. For other vertical applications or ambient conditions, contact the factory.

## Maximum Allowable Low Speed Shaft Thrust Load<sup>‡</sup>

Drive Size	Maximum Thrust Load	
	lbs	kg
2255	5,400	2,450
2275	5,950	2,700
2310	8,900	4,037
2350	10,900	4,945

<sup>‡</sup> The listed thrust ratings are the maximum allowable axial load at the low speed shaft to maintain L<sub>10</sub> of 100,000 hours. Contact the factory if higher thrust load ratings are required.

## Weight and Oil Quantity

Drive Size	Weight		Oil Quantity	
	lbs	kg	gal*	L
2255	1,653	750	7.40	28
2275	1,940	880	9.25	35
2310	2,499	1,134	13.21	50
2350	3,064	1,390	16.38	62

• The volume of oil indicated in the table is only a rough guideline, depending on the ratio the actual oil volume can vary. The exact level of oil is to be maintained as per the dipstick marking or the level indicator as applicable.

## Actual Ratio

Nominal Ratio	Drive Size			
	2255	2275	2310	2350
7.5	7.579	—	—	—
8	8.030	8.026	—	—
8.5	8.526	8.528	—	—
9	9.000	9.191	9.043	—
9.5	9.536	9.529	—	—
10	10.13	10.13	10.17	—
10.5	10.50	10.42	10.67	—
11	11.13	11.12	11.16	11.20
12	12.25	11.81	12.00	11.93
12.5	—	—	12.55	12.61
13	12.98	13.20	13.05	13.07
14	13.78	14.03	14.22	13.92
15	—	15.12	15.09	14.74
15.5	—	—	15.50	15.39
16	—	—	16.00	16.22
17	—	17.15	—	17.19
18	—	—	—	17.93
19	—	—	—	18.93
20	—	—	—	20.03

# NOMENCLATURE GUIDE

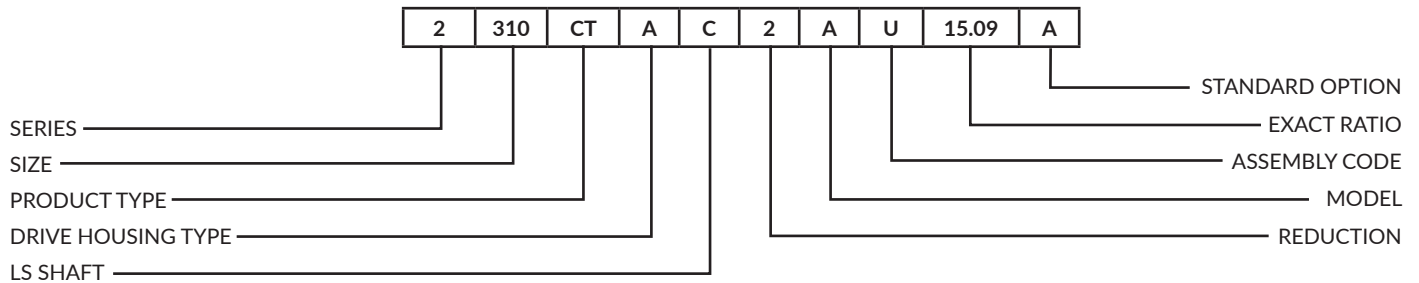

### Series

2000 Series

### Size

255  
275  
310  
350

### Product Type

CT – Falk® CT-Series

### Drive Housing Type/Output Shaft Configuration

A – Right angle drive, matches Amarillo footprint

### LS Shaft

C – Solid shaft

### Reduction

2 – Number of reductions/stages in gear drive

### Model

A – Model A

### Assembly Code

U – L.S. shaft up

### Ratio

Exact ratio expressed as (5) characters including decimal point

### Standard Options

A – Oil level switch  
B – Oil heater with thermostat  
C – Oil sump and HS bearing RTDs  
D – Vibration sensor (HS bearing)

# DIMENSIONS

## Double Reduction Solid Low Speed Shaft, Base Drive — Sizes 2255-2350

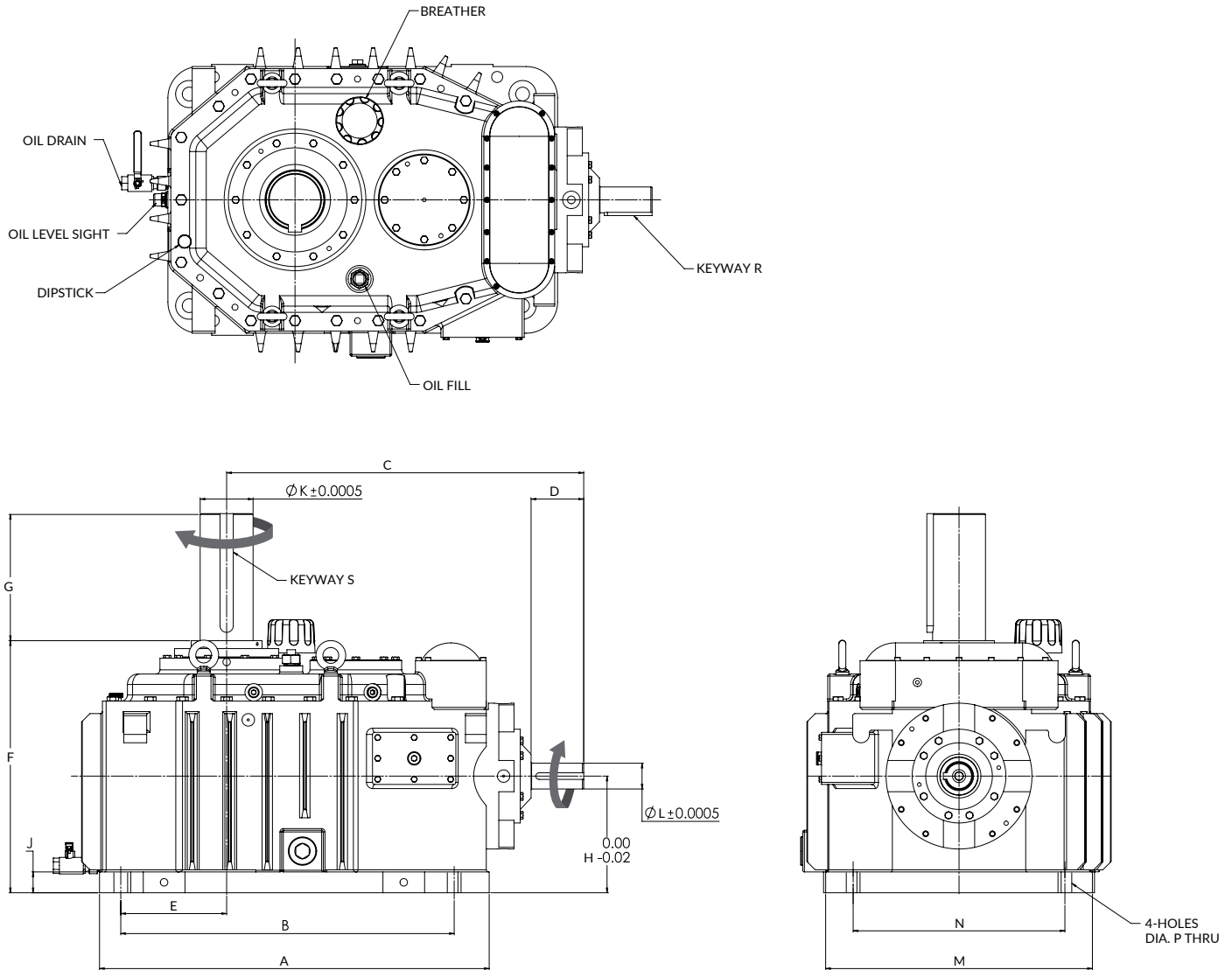

### Dimensions — Inch

Drive Size	A	B	C	D	E	F	G	H	J	K	L	M	N	P	R W x H	S W x H
2255	31.89	25.98	29.75	3.75	8.88	20.63	12.01	9.51	1.97	3.999	1.874	22.05	17.99	1.06	0.375 x 0.188	1.000 x 0.500
2275	34.65	29.25	30.43	4.92	10.37	22.40	12.01	10.26	1.97	4.499	2.436	23.50	19.49	1.30	0.625 x 0.313	1.000 x 0.500
2310	36.81	31.50	33.74	4.92	10.00	23.82	12.01	11.02	1.97	4.999	2.436	25.20	20.00	1.30	0.625 x 0.313	1.250 x 0.625
2350	42.52	34.88	37.24	5.83	11.61	26.10	12.01	12.01	1.57	5.499	2.936	29.25	23.23	1.30	0.750 x 0.375	1.250 x 0.625

# ADDAX® COOLING TOWER BACKSTOP

The Addax Cooling Tower Backstop is an anti-reverse device that mounts directly to coupling hub at either motor or gear drive end. The spring-loaded pawl design allows free rotation in the motor-driven direction, while preventing “reverse windmilling” which could result in costly damage to nearby connected equipment.

- All 316 Stainless Steel construction for superior durability in highly corrosive atmospheres
- Easily mounts directly to Addax Coupling hubs or can be retrofitted to non-Addax hubs.
- Available with Stop Post Assemblies that mount to base plate of type CTA gear drives to enable hassle-free installation



## CTA Stop Post Assemblies

Gear Drive Size	Part Number
2255	10787845
2275	10788006
2310	10781127
2350	10788007

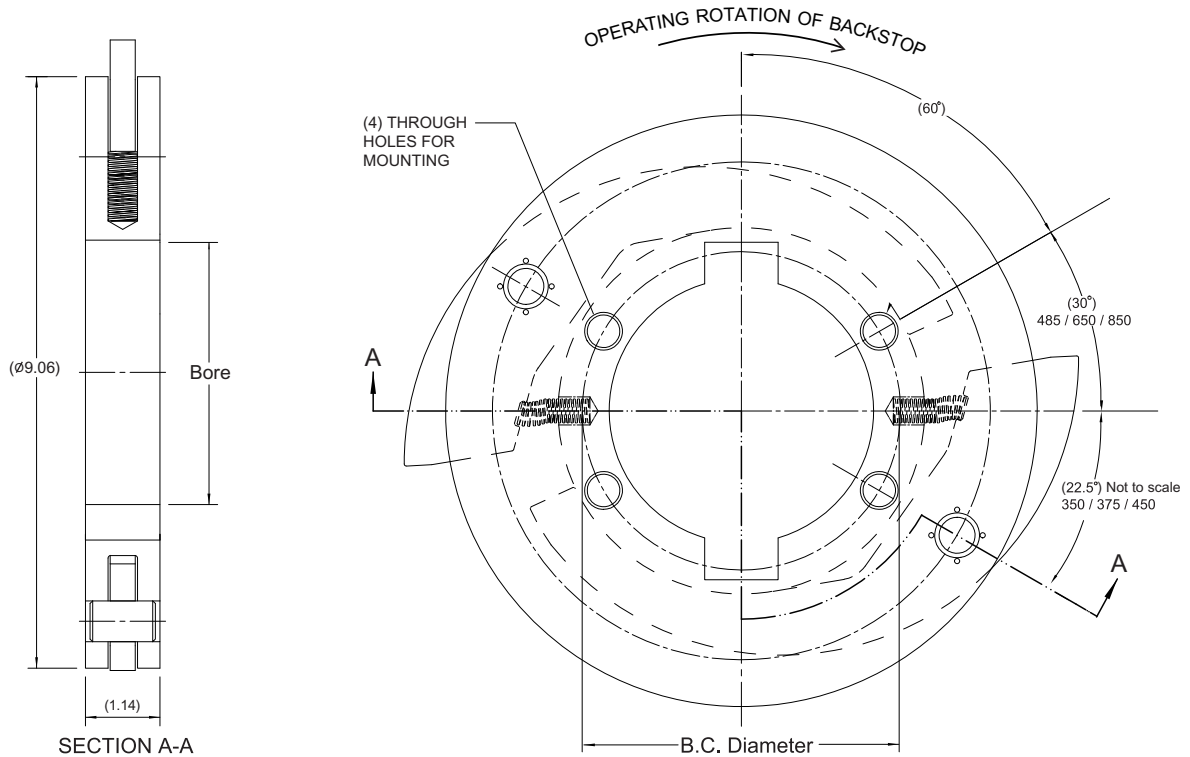

Size	Bore (in)	Mating Hub Backstop Bolting Information			Pawl Diameter		Required Speed for Compression	Part Number	Hub Style
		B.C Diameter (in)	Capscrew Size	Tightening Torque	Compressed	Sprung			
350/375/450	3.02	3-1/2	5/16-18NC X 1.75	195 lb-in	9-3/16 in	10-9/16 in	400 RPM	10299610	Oversized
485	3.44	4-1/16	5/16-18NC X 1.75	195 lb-in				10299611	Oversized
650	4.05	4-5/8	3/8-16NC X 1.75	300 lb-in				10299612	Oversized
850	4.05	4-7/8	1/2-13NC X 2.00	750 lb-in				10299613	Standard

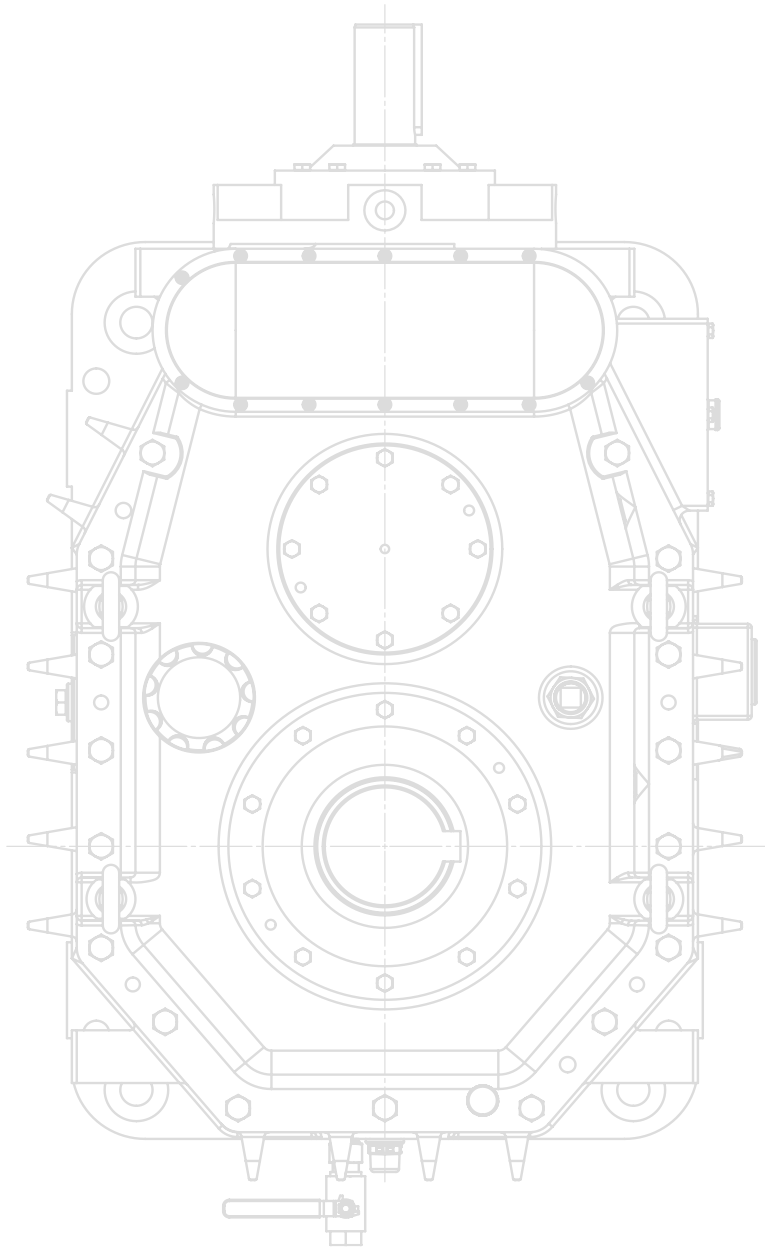

# FALK®

## Motion Control Solutions Regal Rexnord

Contact us: [rexnord.com/contact](https://www.regalrexnord.com/contact)

[regalrexnord.com](https://www.regalrexnord.com)

The proper selection and application of products and components, including assuring that the product is safe for its intended use, are the responsibility of the customer. To view our Application Considerations, please visit <https://www.regalrexnord.com/Application-Considerations>.

To view our Standard Terms and Conditions of Sale, please visit <https://www.regalrexnord.com/Terms-and-Conditions-of-Sale> (which may redirect to other website locations based on product family).

"Regal Rexnord" is not indicative of legal entity.

Regal Rexnord, Falk, and Addax are trademarks of Regal Rexnord Corporation or one of its affiliated companies.

© 2019, 2022 Regal Rexnord Corporation, All Rights Reserved.  
MCB22008E • Form# GR1-010E

 **RegalRexnord**