

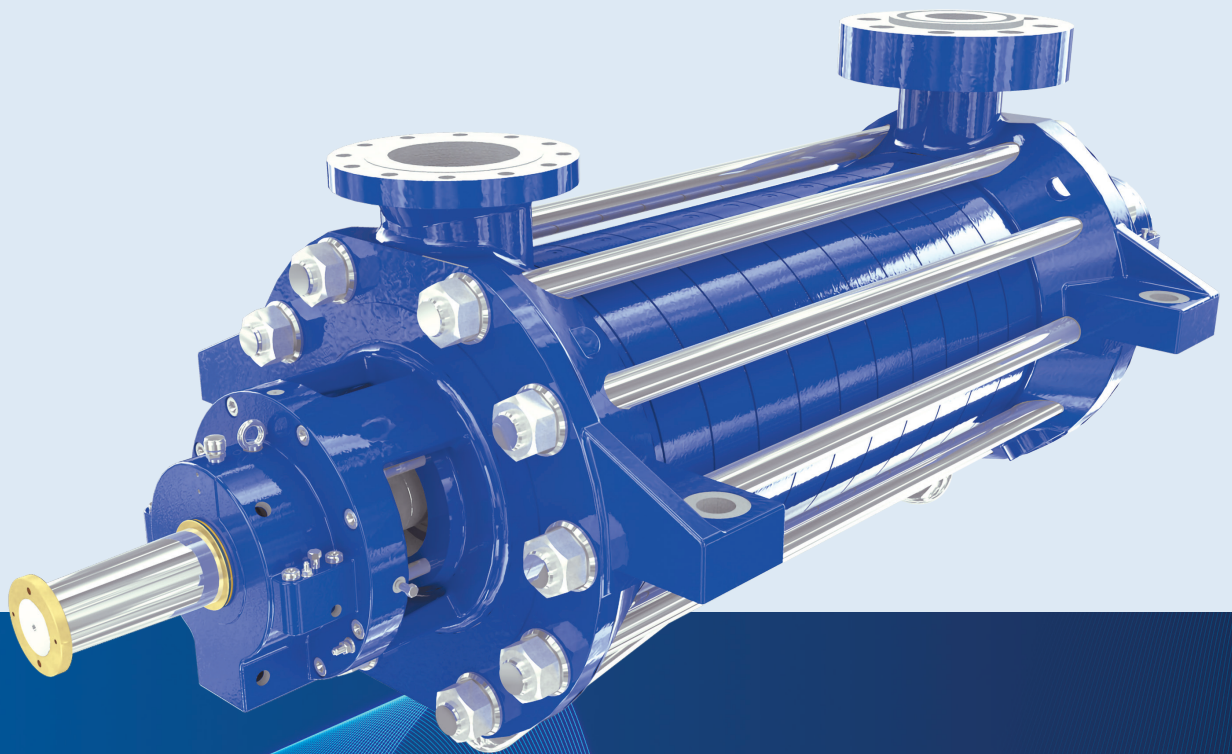

*Specialist for Pumping Technology*



**GP**

**Horizontal, Multi-Stage, Ring-Section Type, Process Pump**

## +75 years developing the pumping technology that drives progress

Ruhrpumpen is an innovative and efficient pump technology company that offers highly engineered, custom made solutions for oil & gas, chemical processing, power generation, industrial applications and water.

Implementation of cutting-edge technology and world-class engineering, combined with our unique vertically integrated structure, allows Ruhrpumpen to design complex technical solutions, creating the most robust and powerful pump systems in the marketplace.

Our broad product line complies with the most demanding quality standards and industry specifications such as **American Petroleum Institute (API), American National Standards Institute (ANSI), Underwriter’s Laboratories (UL), Factory Mutual (FM), National Fire Protection Association (NFPA), ISO and Hydraulic Institute.**

### Products Include:

- Single stage overhung pumps
- Vertical in-line pumps
- Single and multi-stage between bearing pumps
- Multi-stage vertical pumps
- Reciprocating plunger pumps
- Sealless magnetic drive pumps
- Fire protection systems
- Pitot tube pumps
- Hydraulic decoking systems
- Horizontal pumping systems



### Ruhrpumpen is your single source supplier

- Original Equipment
- Spare parts
- Installation and startup support
- Repair and maintenance
- Engineering, training and consulting
- Reverse engineering

### Benefits of our pumps

- Proven reliability
- High efficiency designs ensure lowest operating cost
- Robust design allows for long system life with minimal maintenance
- Optimized total cost of ownership

## GP Pump

### Ruhrpumpen’s BB4, Ring Section Pump

The GP pump is a horizontal, between bearings, multi-stage, radially split, ring section type centrifugal pump. It is engineered to be the most reliable and efficient pumping solution for the most demanding high-pressure and high-temperature applications across many industries.

Its robust, yet compact, design, together with high efficiency hydraulics, provides superior performance and exceptional reliability combined with ease of maintenance and minimal operating costs.

The GP line is available in non-API builds for the requirements of power plants and general industry specifications, and as API 610 11th edition (BB4 type) compliant for oil and gas applications. It is designed to meet group II, category 2 G and 3 (for use in zone 1 and 2) of the ATEX 94/9/C directive.



# Performance Range

## SELECTION CHART GP n= 2960 RPM

50 Hz

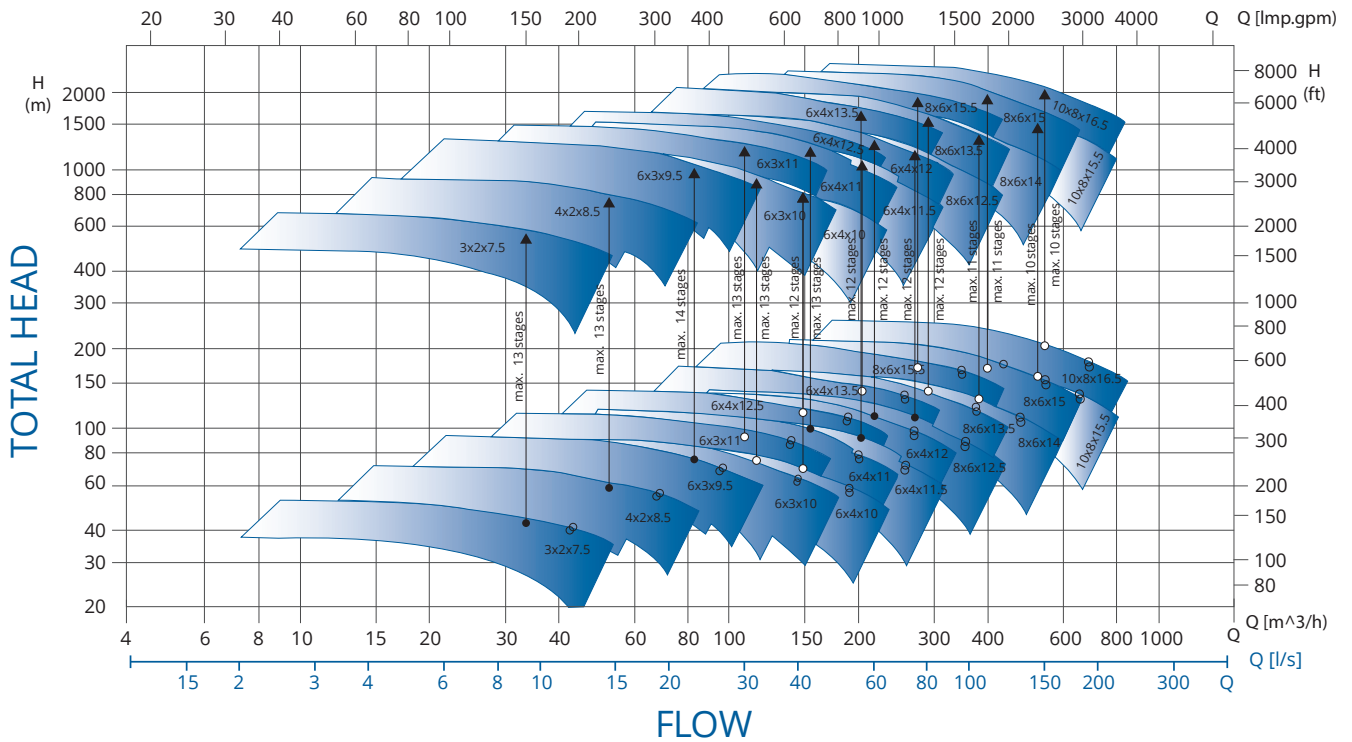

## SELECTION CHART GP n= 3560 RPM

60 Hz

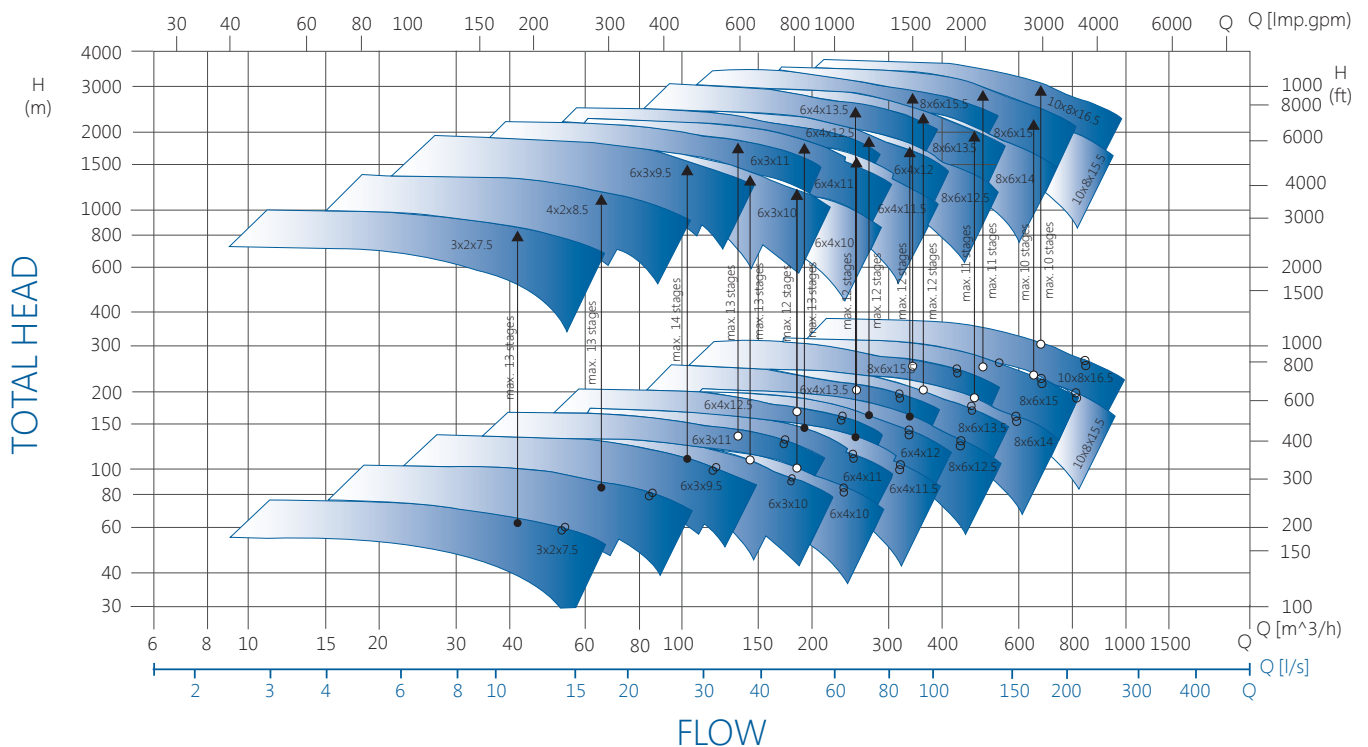

## GP Pump for Heavy-Duty Applications

**1** Balancing disk compensates 100% of the axial, hydraulic forces meaning no thrust bearing is required. Provides optimized efficiency.

**2** Rigid, 360° bearing support ensures low vibration.

**3** Clamped bearing cover without screws provides better access to the seals.

**4** Bearing housing with vertical fins provides optimal cooling, no end cover.

**5** Single row, cylindrical roller, radial bearings with splash oil lubrication and constant level oiler.

**6** Optional radial sleeve bearings.

**7** Water cooled bearing housing.

**19** Casings are sealed with elastomeric o-rings suitable for rapid temperature variations. Elastomers are confined in grooves and therefore not subject to shear forces and so are less likely to be damaged during assembly and disassembly.

**18** Impellers, enclosed, investment casting obtain best efficiency and repeatability of hydraulic data.

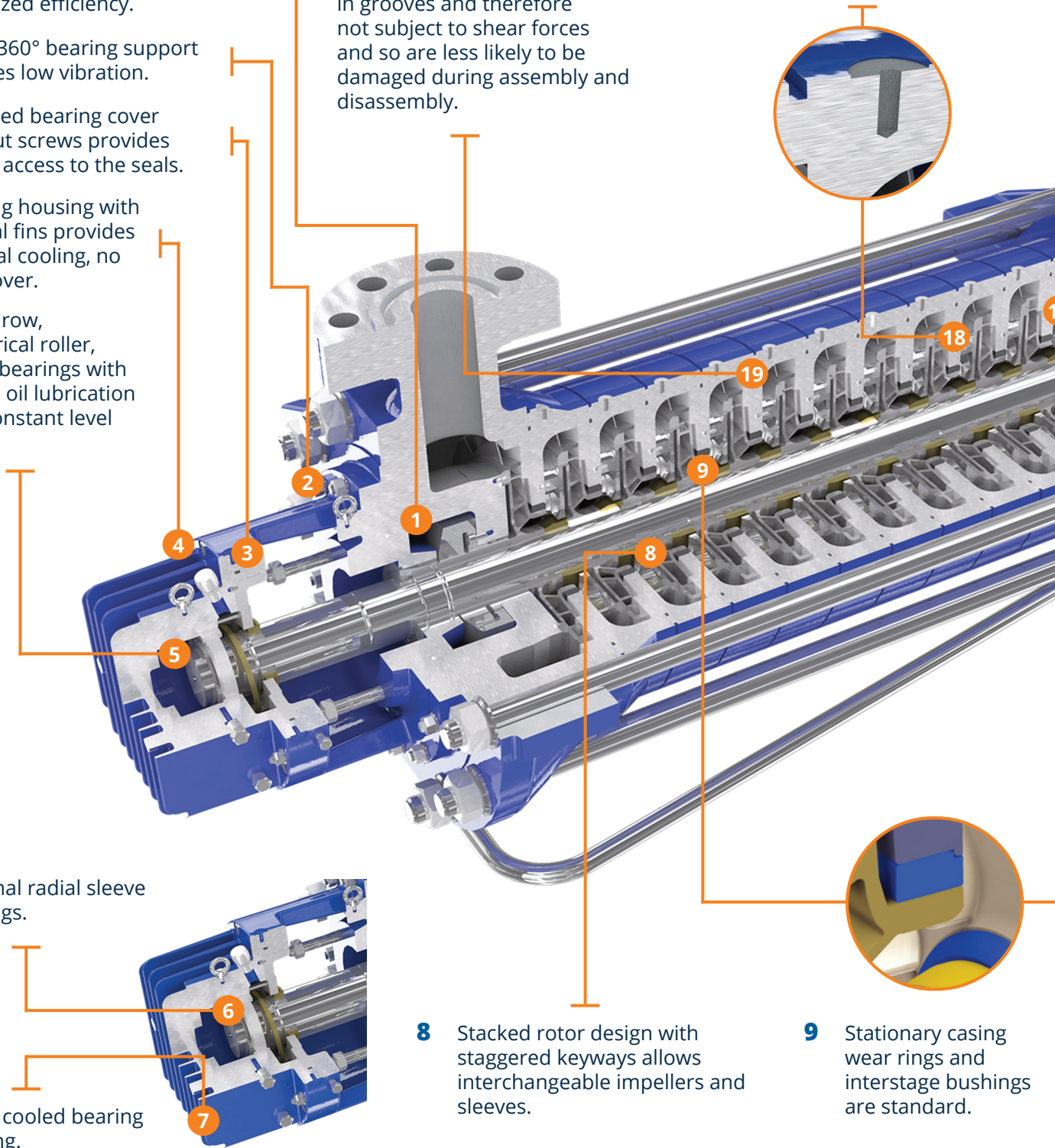

**8** Stacked rotor design with staggered keyways allows interchangeable impellers and sleeves.

**9** Stationary casing wear rings and interstage bushings are standard.

Images for general arrangement use only, not certified for construction.

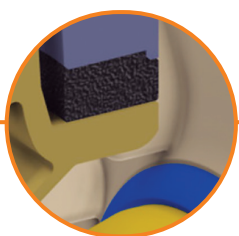
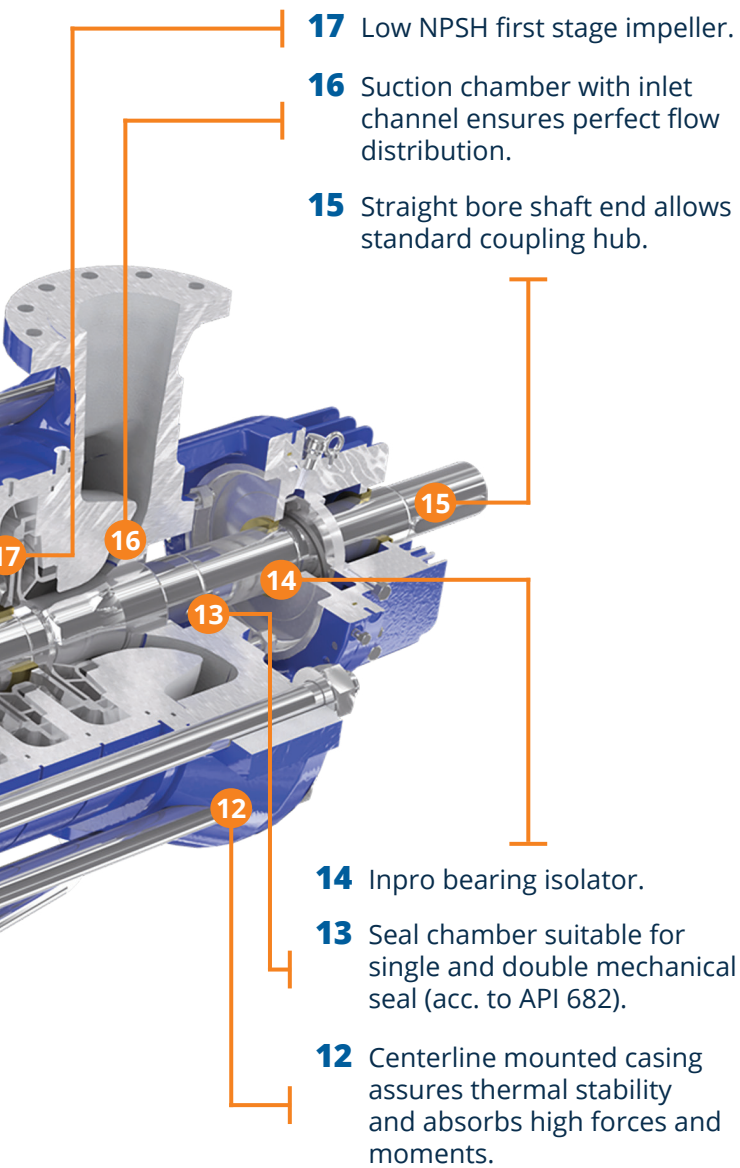

**10** Replaceable impeller wear ring.

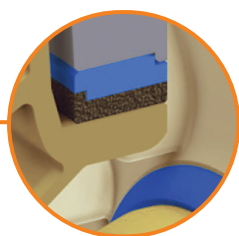

**11** Replaceable impeller wear ring with non-metallic stationary ring.

## DESCRIPTION

- Horizontal, between bearings, centrifugal pump.
- Multi-stage, radially split, single case.
- Centerline mounted.
- Ring section type pump.
- Counter-clockwise rotation only.

## BENEFITS

- Thrust balancing by balance disk or balance drum available.
- A and B series stage hydraulics available to match different head/flow requirements with maximum efficiency.
- Low NPSH (type IS) first stage impeller designs.
- Alternate series hydraulic (type IM) optimized for interstage take-off.
- Optimized inter stage hydraulics (type IM) for inter stage takeoff.
- Cold start possible for most applications (no warmup needed).
- Multiple bearing configuration options.
- API 610 compliant design (BB4 type) and heavy-duty industrial configurations available.
- Standard materials of construction per API 610 (other materials on request).
- Centerline mounted casing provides optimum performance in high temperature services.
- "Blind" stages for future upgrades available.
- Single and double mechanical seals available.

## BROAD APPLICATION RANGE

High-pressure and high-temperature applications across industries:

- Petrochemical
- Refineries
- Boiler feed water service
- Descaling
- Water injection
- Desalination
- Reverse osmosis

## Balancing Device and Bearing Selection

### The Resultant of all Axial Thrust Forces from the Inline Arranged I

#### Balancing Disk:

The balancing disk design (illustrated in the pump section in previous page) is able to compensate 100% of the axial thrust along the complete operating range, by means of a throttling gap and close axial clearance between the rotor-mounted disk and the stationary part of the pump which is self-regulating as the rotor makes small adjustment in its position depending on the axial thrust of the impellers.

As a result, this design does not require a thrust bearing and can be offered with a simple anti-friction or sleeve radial bearing, even at very high powers, hence offering considerable cost and technical benefits compared with tilting pad thrust bearing.

#### Disk Lift-off Device:

The lift-off device is an optional feature which ensures that the balancing disk is open during the rest, start-up and run-down of the pump by means of a preloaded spring and an angular contact ball bearing. This feature provides highest levels of reliability for applications where frequent starts/stops are expected.

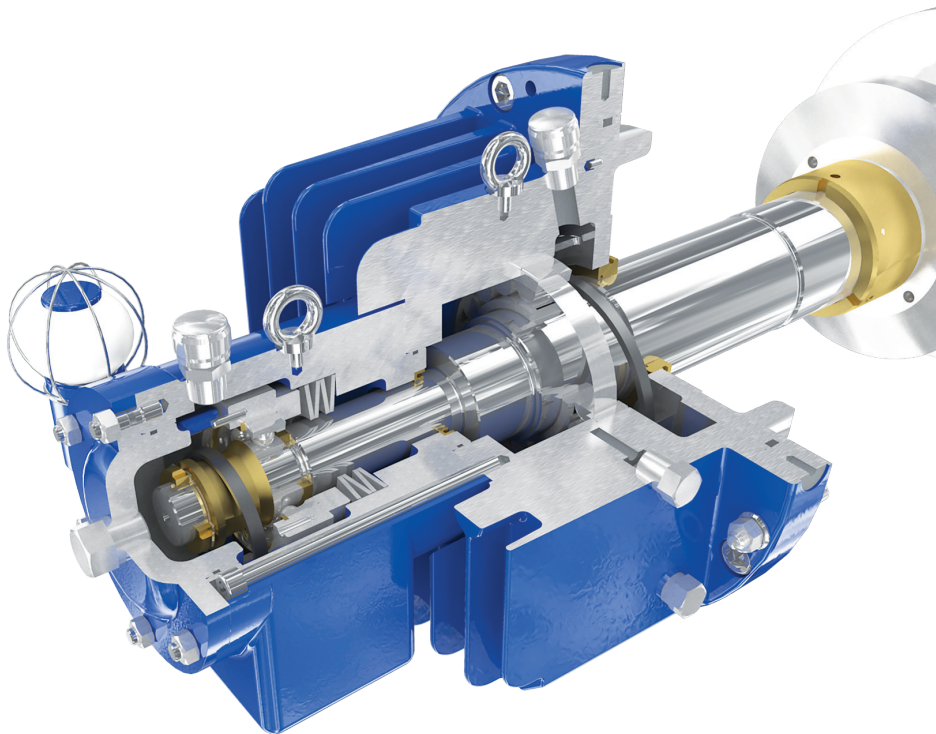

Images for general arrangement use only, not certified for construction.

## Impellers is Compensated by a Balancing Disk or a Balancing Drum.

### Balancing Drum:

The balance drum compensates up to 90% of axial forces by means of a close radial clearance. This design is particularly suitable for applications where the pumped fluid contains solids and where full API 610 compliance is required.

Anti-friction thrust bearing arrangement is available for lower powers, as well as hydrodynamic (tilting pad) thrust bearings for higher powers. Where tilting pad bearings are required Ruhrpumpen has many years of experience to allow us to specify and design a complete package including lubrication system suitable for the application.

**2** Paired back to back, single row, angular contact ball bearings with splash oil lubrication and constant level oiler.

**3** Balancing drum with radial clearance.

**1** Water cooled bearing housing.

**4** Double acting tilting pad thrust bearing absorbs the residual axial thrust.

**5** Axial split bearing housing for forced feed lubrication.

**6** Shaft mounted main oil pump for forced feed lubrication.

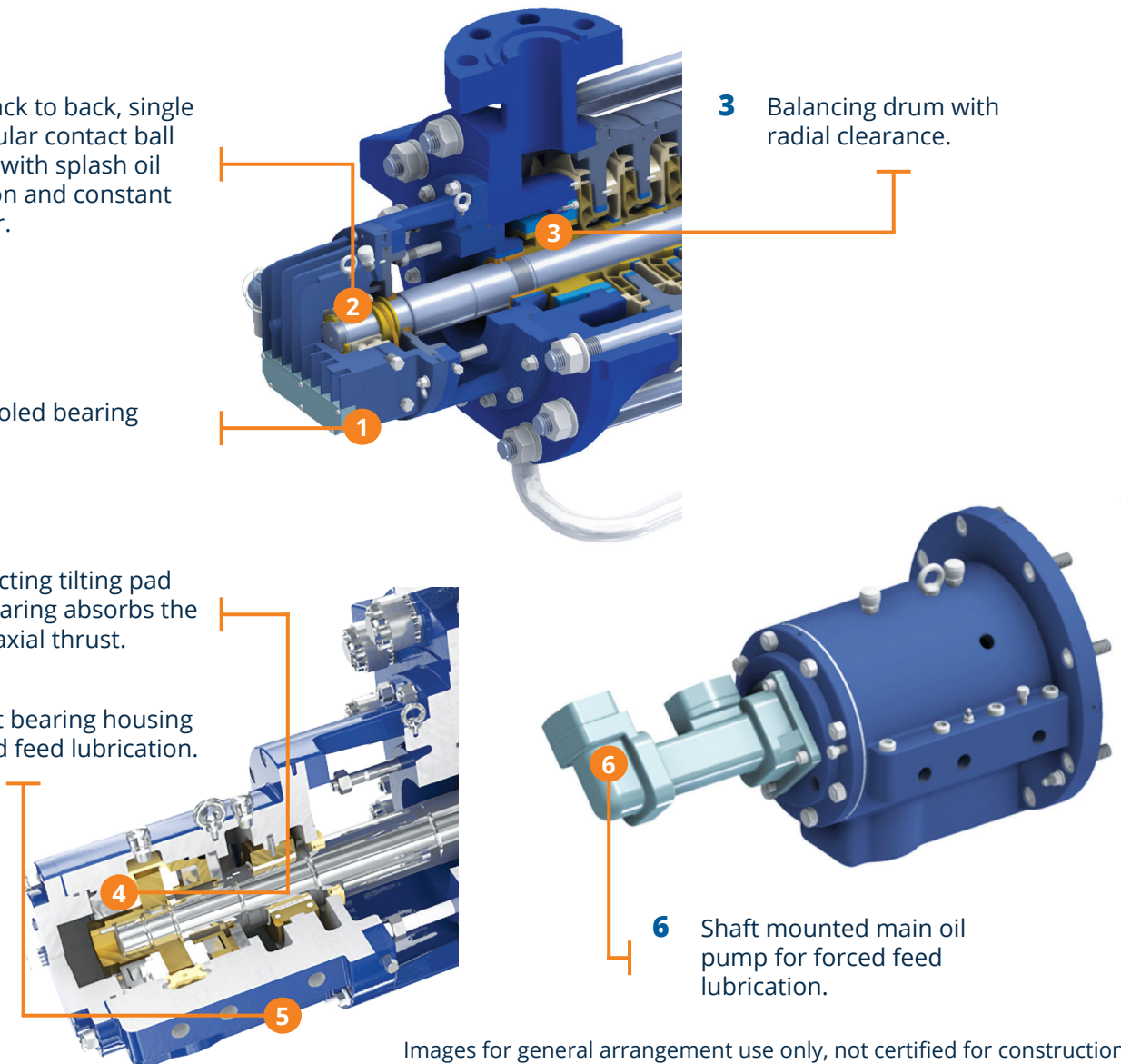

Images for general arrangement use only, not certified for construction.

## Optional Features for API Pumps and Higher Powers Pumps

Ruhrpumpen offers multiple screw mechanical tensioners as a replacement for conventional nuts for tie rods on larger pumps and applications where cold starting is expected.

### MULTIPLE SCREW MECHANICAL TENSIONERS IN SAME

- Multiple screw mechanical tensioners provide pure tensile load, no torsional stress is introduced to the tie-rods. Absence of axial stresses allows higher capability of the rods.
- Ensures uniform tightening on all tie rods.
- Tie rod elongation can be measured as the gap between the nut body and the washer, giving additional verification of the tightening torque used.
- Allows bolt tightening by use of simple hand tools (no need for heavy hydraulic tool) meaning that re-assembly is faster and simpler in the field and no special tools needed.

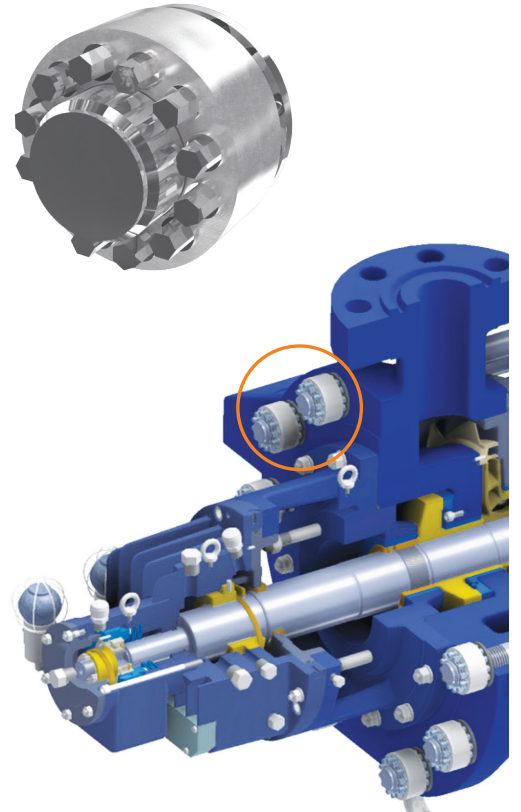

### INTERSTAGE TAKE-OFF

- 1 or 2 interstage take-off nozzles can be provided to supply flow of process fluid at less than full discharge pressure.
- Nozzle is welded to the appropriate stage casing.
- Special 'IM' hydraulics utilized for the stages carrying full suction flow. These are designed for higher flows than standard hydraulics, to ensure all stages running close as possible to best efficiency point, thus optimizing the total pump efficiency.

### SHAFT DESIGN

**Stepped shaft with individually secured impellers for applications with higher differential pressures.**

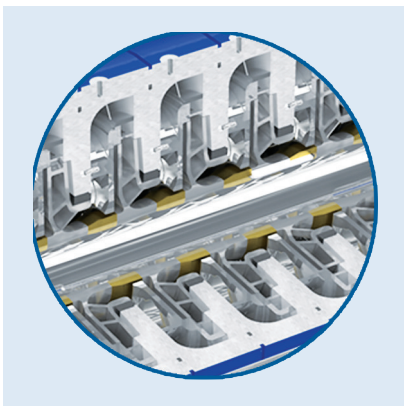

Stepped shaft for applications with higher differential pressures and individually secured impellers available where API 610 compliance is required.

## Aftermarket Services



Our dedication to our customers goes beyond simply supplying world-class products. Our dedicated Aftermarket Staff is ready and waiting to assist you in solving all your pumping needs. Our worldwide service network offers: spare parts, standard overhauls, repair and maintenance packages, on-site inspections, recommended upgrades and failure analysis to ensure the serviced equipment performs beyond expectations.

## Reverse Engineering Aftermarket Parts (REAP)

Our Reverse Engineering of Aftermarket Parts (REAP) is a specialized team within Ruhrpumpen's Aftermarket services that can replicate broken or worn pump parts for any pump model from any manufacturer. This way, we develop the spare parts of discontinued pump models so our clients don't have to invest in a brand new pump just because spare parts are no longer available.

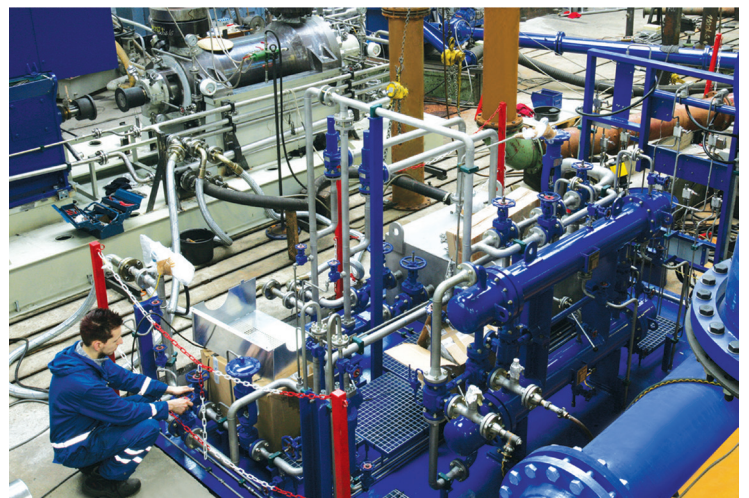

Original Damaged Part

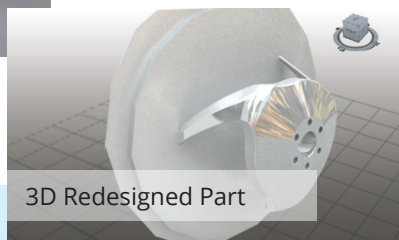

3D Redesigned Part

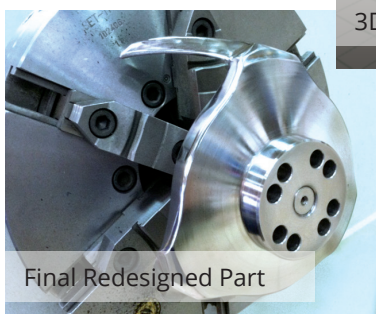

Final Redesigned Part

## Synergetic Retrofit

Through our Synergetic Retrofit service, we adapt existing pump installations to new operating conditions, enhancing operating capacities and improving reliability of the pumping system.

### Benefits:

- Maximized throughput
- Optimized total cost of ownership
- Reduced energy consumption
- Extended run-time
- Short downtime as compared to acquiring a new pump

## Boiler Feed Water Pump

At the heart of the power generation process, the Boiler Feed Water Pump (BFP) plays an essential role, feeding high pressure and high temperature water to a steam generator, such as a Boiler or HRSG (Heat Recovery Steam Generator).

Ruhrpumpen has recognized the demand for the highest levels of up-time in designing our GP pump which is ideally suited to this demanding (high temperature, high pressure) service – particularly in combined cycle plants where severe cycling and thermal transients can occur. Its compact design, high efficiency, investment cast hydraulics and optimized clearances provide superior performance and exceptional reliability combined with easy maintenance and minimal operating costs.

## Combined Cycle Schematic

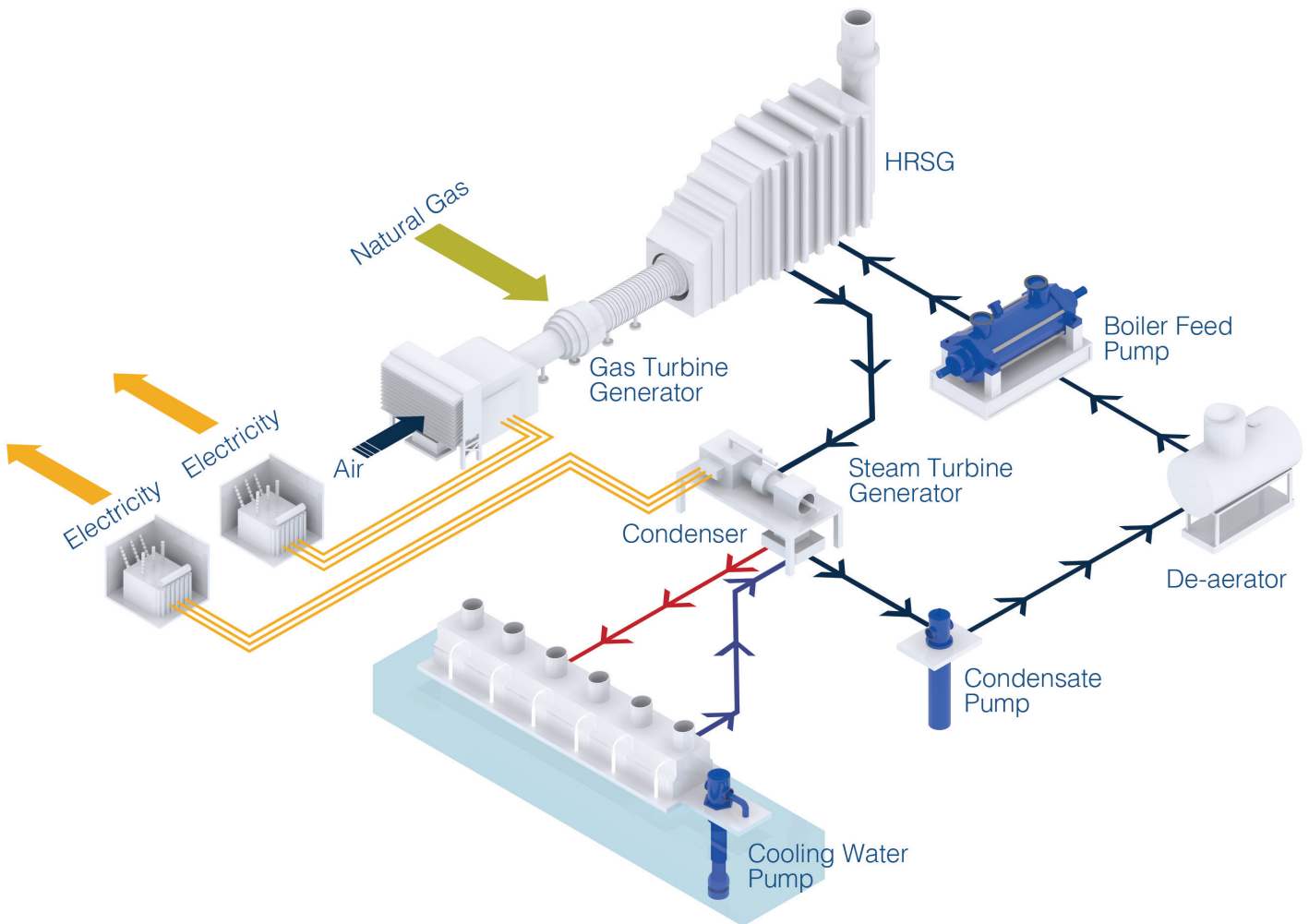

## Ruhrpumpen has a complete offering for Power Plant pumping needs!

### Condensate Pumps

Condensate pumps are required to handle low pressure water leaving the condenser, hence this service often requires a vertical canned pump suitable for use on low or zero NPSH applications.

- Models VLT, VTP and VCT are vertical multi stage canned pumps suited for condensates.
- Low NPSH3 first stage impeller designed to match series stage flow rates. This first stage impeller is designed to provide shockless fluid entry with optimized eye/vane inlet angles – they are not typical “large eye impellers” operating away from their best efficiency point.
- Option for double suction first stage for higher flow rates.
- Keyed impellers
- Mechanical seal



### Cooling Water Pumps

Cooling Water Pumps circulate large volumes of water from cooling towers or other sources, such as a lake or river, to the condenser. Typically require high flows, but low head.

- The VCT vertical circulating pump line has been designed specifically for water services.
- Suitable for high flows with diameters over 108” (2800 mm).
- Industry-leading high efficiencies.
- +2,500 installations of this pump worldwide by RP.

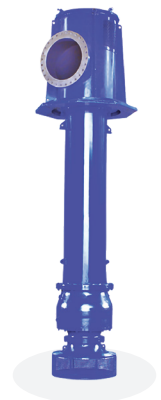

### General Service Pumps

Wide range of vertical and horizontal pumps, including ANSI, ISO and API designs, to fulfill all general service duties.



### Fire Fighting Pumps and Systems

Condensate pumps are required to handle low pressure water leaving the condenser, hence this service often requires a vertical canned pump suitable for use on low or zero NPSH applications.

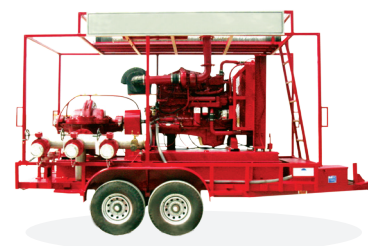
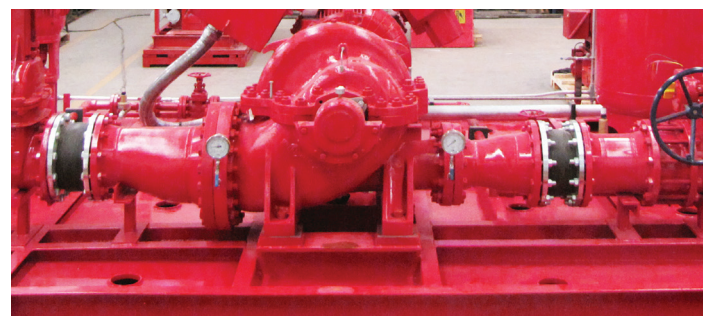









## +75 years creating the pumping technology that moves our world

Ruhrpumpen is an innovative and efficient pump technology company that offers highly-engineered and standard pumping solutions for the oil & gas, power generation, industrial, water and chemical markets. We offer a broad range of centrifugal and reciprocating pumps that meet and exceed the requirements of the most demanding quality specifications and industry standards such as API, ANSI, UL, FM, ISO and Hydraulic Institute.



### Ruhrpumpen Plants

-  ARGENTINA, Buenos Aires
-  BRAZIL, Rio de Janeiro
-  CHINA, Changzhou
-  EGYPT, Suez
-  GERMANY, Witten
-  INDIA, Chennai
-  MEXICO, Monterrey
-  UK, Lancing
-  USA, Tulsa

-  Manufacturing plant & service center
-  Service center