



SEW
EURODRIVE

Operating Instructions



Gear Unit Series BS.F., PS.F. and PS.C.



Table of Contents

1	General information	6
1.1	About this documentation	6
1.2	Validity of the documentation	6
1.3	Other applicable documentation	6
1.4	Structure of the safety notes	6
1.4.1	Meaning of signal words	6
1.4.2	Structure of section-related safety notes	6
1.4.3	Structure of embedded safety notes	7
1.5	Decimal separator in numerical values	7
1.6	Rights to claim under limited warranty	7
1.7	Product names and trademarks	7
1.8	Copyright notice	7
2	Safety notes	8
2.1	Preliminary information	8
2.2	Duties of the user	8
2.3	Target group	9
2.4	Designated use	9
2.5	Transportation/storage	10
2.6	Installation/assembly	10
2.7	Startup/operation	11
2.8	Cleaning	11
2.9	Inspection/maintenance	11
3	Gear unit structure	12
3.1	BSF602 helical-bevel gear unit with EBH.. adapter	12
3.2	BSBF602 helical-bevel gear unit with EBH.. adapter	13
3.3	BSHF602 helical-bevel gear unit with EBH.. adapter	14
3.4	BSAF602 helical-bevel gear unit with EBH.. adapter	14
3.5	PSF621 planetary gear unit with EPH.. adapter	15
3.6	PSBF621 planetary gear unit with EPH.. adapter	15
3.7	PSC521 planetary gear unit with ECH.. adapter	16
3.8	PSCZ521 planetary gear unit with ECH.. adapter	16
3.9	Nameplate/type designation	17
3.9.1	Sample nameplates for planetary gear units PSC.. with adapter ECH..	17
3.9.2	Example: Type designation of PSF.. planetary gear unit with EPH.. adapter	18
3.9.3	Example: Nameplate of directly mounted PS.F.. servo gearmotor	19
3.9.4	Example: Type designation of PS.F.. helical-bevel gear unit with directly mounted CMP.. motor	20
4	Mechanical installation	21
4.1	Prerequisites for installation	21
4.2	Required tools and resources	22
4.3	Installation tolerances	22
4.4	Directions of rotation	23
4.4.1	Definitions	23

4.4.2	Direction of rotation of the gear unit.....	24
4.5	Mounting the gear unit to a machine.....	25
4.5.1	Bolt sizes	25
4.5.2	Changing the mounting position	26
4.5.3	Customer construction	26
4.5.4	Electrochemical corrosion protection.....	26
4.5.5	Tightening torques for retaining screws.....	27
4.5.6	Installation in damp areas or in the open.....	28
4.5.7	Gear unit venting	28
4.5.8	Painting gear units	30
4.6	Installation in a machine: BS.F.. helical-bevel gear units.....	31
4.6.1	BS.F.: Bolted from the gear unit end via the B5 flange:	31
4.6.2	BSBF..B: Screw fitting at the foot and front end	32
4.7	Installation in a machine: PS.F.. planetary gear units.....	33
4.7.1	PS.F.: Bolted from the gear unit end via the B5 flange:	33
4.8	Installation in a machine: PS.C.. planetary gear units	34
4.8.1	PS.C.: Bolted from the gear unit end via the B5 flange	34
4.8.2	PS.CZ.: Bolted from the gear unit end via the B14 flange.....	34
4.9	Mounting the output elements to the output shaft.....	35
4.9.1	Mounting the gear unit – solid shaft design with key	35
4.9.2	Mounting the gear unit – smooth solid shaft design	37
4.9.3	Flange block shaft assembly	38
4.10	Mounting of couplings	38
4.11	Installing a torque arm on BS.F.. shaft-mounted gear units.....	39
4.12	Mounting shaft-mounted gear units with a keyway	40
4.13	Shaft-mounted gears unit with shrink disk	41
4.13.1	Mounting shaft mounted gear units with shrink disk.....	41
4.13.2	Removing shaft-mounted gear units with shrink disk	44
4.13.3	Cleaning and lubricating the shrink disk	44
4.14	Mounting the motor on a gear unit using an adapter	45
4.14.1	Mounting motor via EBH.. and EPH.. adapters	45
4.14.2	Motor mounting via ECH.. adapter	48
4.14.3	Permitted motor weight with adapter EBH., EPH., ECH.....	50
4.14.4	Mounting motors to gear units directly.....	51
4.15	Removing the motor from the adapter	52
4.15.1	Sequence for demounting the motor from adapter EBH., EPH.. or ECH.. ..	52
5	Startup.....	53
5.1	Design-related special features	53
5.1.1	BS.F.. helical-bevel gear units for mounting position M5.....	53
5.1.2	PSF.. /PSKF.. planetary gear units for mounting position M2	53
5.2	Measuring the surface temperature	54
6	Inspection and Maintenance	55
6.1	Preliminary work regarding gear unit inspection/maintenance	55
6.2	Inspection and maintenance intervals.....	56
6.2.1	Wearing parts	56

6.2.2	Measuring the oil temperature	57
6.3	Lubricant change intervals	58
6.4	Lubricants	59
6.4.1	Bearing greases.....	59
6.4.2	Lubricant table	59
6.4.3	Lubricant fill quantities	65
6.5	Extended storage.....	69
6.5.1	Storage conditions for long-term storage.....	69
7	Mounting positions	71
7.1	General information on the mounting positions – BS.F, PS.F, PS.C gear units	71
7.2	Mounting position sheets	72
7.2.1	Dimension sheet information	72
7.2.2	Mounting positions of BS.F helical-bevel gearmotors.....	73
7.2.3	Mounting positions of PS.F, PS.C planetary gearmotors	82
8	Malfunctions	84
8.1	Failures on the servo gear unit	84
8.2	Service	84
8.3	Waste disposal.....	85
9	Address list.....	86
	Index	97

1 General information

1.1 About this documentation

The documentation at hand is the original.

This documentation is an integral part of the product. The documentation is intended for all employees who perform work on the product.

Make sure this documentation is accessible and legible. Ensure that persons responsible for the systems and their operation as well as persons who work on the product independently have read through the documentation carefully and understood it. If you are unclear about any of the information in this documentation or if you require further information, contact SEW-EURODRIVE.

1.2 Validity of the documentation

The operating instructions at hand are valid only for products with a type designation according to the type code described in chapter "Device structure".

1.3 Other applicable documentation

Observe the corresponding documentation for all additional components.

1.4 Structure of the safety notes

1.4.1 Meaning of signal words

The following table shows the graduation and meaning of the signal words in the warnings:

Signal word	Meaning	Consequences if not observed
▲ DANGER	Imminent danger	Death or severe injuries
▲ WARNING	Possible dangerous situation	Death or severe injuries
▲ CAUTION	Possible dangerous situation	Minor injuries
NOTICE	Possible damage to property	Damage to the product or its environment
INFORMATION	Useful information or tip: Simplifies handling of the product.	

1.4.2 Structure of section-related safety notes

Section-related safety notes do not apply to a specific action but to several actions pertaining to one subject. The hazard symbols used either indicate a general hazard or a specific hazard.



This is the formal structure of a safety note for a specific section:

SIGNAL WORD

Type and source of hazard.

Possible consequence(s) if disregarded.

- Measure(s) to prevent the hazard.

1.4.3 Structure of embedded safety notes

Embedded safety notes are directly integrated into the instructions just before the description of the dangerous step.

This is the formal structure of an embedded safety note:

▲ SIGNAL WORD! Type and source of danger. Possible consequence(s) if disregarded. Measure(s) to prevent danger.

1.5 Decimal separator in numerical values

In this document, a period is used to indicate the decimal separator.

Example: 30.5 kg

1.6 Rights to claim under limited warranty

Read the information in this documentation. This is essential for fault-free operation and fulfillment of any rights to claim under limited warranty. Read the documentation before you start working with the product.

1.7 Product names and trademarks

The product names mentioned in this documentation are trademarks or registered trademarks of the respective titleholders.

1.8 Copyright notice

© 2023 SEW-EURODRIVE. All rights reserved. Copyright law prohibits the unauthorized reproduction, modification, distribution and use of this document – in whole or in part.

2 Safety notes

2.1 Preliminary information

The following general safety notes serve the purpose of preventing injury to persons and damage to property. They primarily apply to the use of products described in this documentation. If you use additional components, also observe the relevant warning and safety notes.

2.2 Duties of the user

As the user, you must ensure that the basic safety notes are observed and complied with. Make sure that persons responsible for the machinery and its operation as well as persons who work on the device independently have read through the documentation carefully and understood it.

As the user, you must ensure that all of the work listed in the following is carried out only by qualified specialists:

- Setup and installation
- Installation and connection
- Startup
- Maintenance and repairs
- Shutdown
- Disassembly

Ensure that the persons who work on the product pay attention to the following regulations, conditions, documentation, and information:

- The national and regional regulations governing safety and the prevention of accidents
- The warning and safety signs on the product
- All other associated project planning documents, installation and startup instructions, as well as wiring diagrams
- Do not assemble, install or operate damaged products
- All system-specific specifications and regulations

Ensure that systems in which the product is installed are equipped with additional monitoring and protection devices. Observe the applicable safety regulations and legislation governing technical work equipment and accident prevention regulations.

2.3 Target group

Specialist for mechanical work	<p>Any mechanical work may be performed only by adequately qualified specialists. Specialists in the context of this documentation are persons who are familiar with the design, mechanical installation, troubleshooting, and maintenance of the product, and who possess the following qualifications:</p> <ul style="list-style-type: none"> • Qualifications in the field of mechanics in accordance with the national regulations • Familiarity with this documentation
Specialist for electrotechnical work	<p>Any electrotechnical work may be performed only by electrically skilled persons with a suitable education. Electrically skilled persons in the context of this documentation are persons who are familiar with electrical installation, startup, troubleshooting, and maintenance of the product, and who possess the following qualifications:</p> <ul style="list-style-type: none"> • Qualifications in the field of electrical engineering in accordance with the national regulations • Familiarity with this documentation
Additional qualifications	<p>In addition to that, these persons must be familiar with the valid safety regulations and laws, as well as with the requirements of the standards, directives, and laws specified in this documentation.</p> <p>The persons must have the express authorization of the company to operate, program, parameterize, label, and ground devices, systems, and circuits in accordance with the standards of safety technology.</p>
Instructed persons	<p>All work in the areas of transport, storage, installation, operation and waste disposal may only be carried out by persons who are trained and instructed appropriately. These instructions must enable the persons to carry out the required activities and work steps safely and in accordance with regulations.</p>

2.4 Designated use

The product is intended for use in industrial and commercial systems.

In case of installation in electrical systems or machines, startup of the product is prohibited until it is determined that the machine meets the requirements stipulated in the local laws and directives. For Europe, Machinery Directive 2006/42/EC as well as the EMC Directive 2014/30/EU apply.

Use in potentially explosive atmospheres is prohibited, unless specifically designated otherwise.

2.5 Transportation/storage

Observe the storage information concerning climatic conditions in accordance with chapter "Extended storage".

The permissible storage temperature is -30 °C to +50 °C.

If the product is not immediately installed, it must be stored in a dry and dust-free location. The product can be stored for up to 9 months without requiring any special measures before startup. Do not store the product outdoors.

The installed lifting eyebolts are in accordance with DIN 580. Observe the loads and regulations specified there. The tension force vector of the slings must not exceed a 45° angle in accordance with DIN 580.

The lifting eyes are designed to carry only the weight of the product. Do not mount any additional loads. If the product has several lifting eyes or lifting eyebolts, then you should use all lifting eyes and lifting eyebolts for attaching transport ropes. Tighten the screwed-in lifting eyes.

Use suitable, sufficiently rated handling equipment, that can be used for further transport.

PS.C gear units can basically not be put into extended storage.

Please contact SEW-EURODRIVE for issues relating to extended storage for PS.F gear units.

2.6 Installation/assembly

Ensure that the product is installed and cooled according to the regulations in the documentation.

Protect the product from strong mechanical strain. The product and its mounting parts must never protrude into the path of persons or vehicles. Ensure that components are not deformed, particularly during transportation and handling. Electrical components must not be mechanically damaged or destroyed.

The following applications are prohibited unless the device is explicitly designed for such use:

- Operation in applications with impermissibly high mechanical vibration and shock loads in excess of the regulations stipulated in EN 61800-5-1.
- Use in areas exposed to harmful oils, acids, gases, vapors, dust, radiation, etc.

Before using a stainless steel shrink disk or stainless steel output shaft, check if the ambient conditions are compatible with the stainless steel material. For information on the material, refer to the order confirmation.

2.7 Startup/operation

Check that the direction of rotation is correct in the **decoupled** state. Listen out for unusual grinding noises as the shaft rotates.

Secure the keys for the test run without output elements.

Do not deactivate monitoring and protection devices even for a test run.

Switch off the gearmotor if in doubt whenever changes occur in relation to normal operation (e.g. increased temperatures, unusual noises, vibrations). Determine the cause. It may be necessary to contact SEW-EURODRIVE.

2.8 Cleaning

When using a stainless steel shrink disk or stainless steel output shaft, check if the cleaning agents and chemicals are compatible with the stainless steel material. For information on the material, refer to the order confirmation.

2.9 Inspection/maintenance

Observe the information in chapter "Inspection/maintenance".

3 Gear unit structure

INFORMATION



The following figures are block diagrams. Their purpose is only to make it easier to assign components to the spare parts lists. Discrepancies may occur depending on the gear unit size and version.

3.1 BSF602 helical-bevel gear unit with EBH.. adapter

The following figure shows an example of a helical-bevel gear unit with solid shaft and B5 output flange.

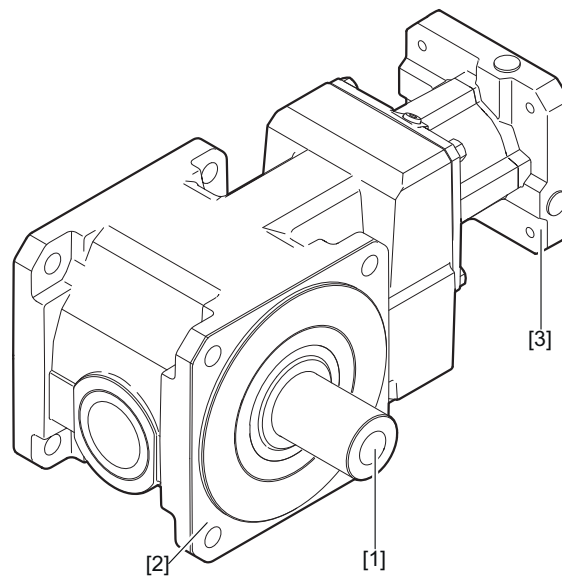

29328913291

- [1] Solid shaft
- [2] B5 output flange
- [3] EBH.. adapter

3.2 BSBF602 helical-bevel gear unit with EBH.. adapter

The following figure shows an example of a helical-bevel gear unit with flange block shaft and B5 output flange.

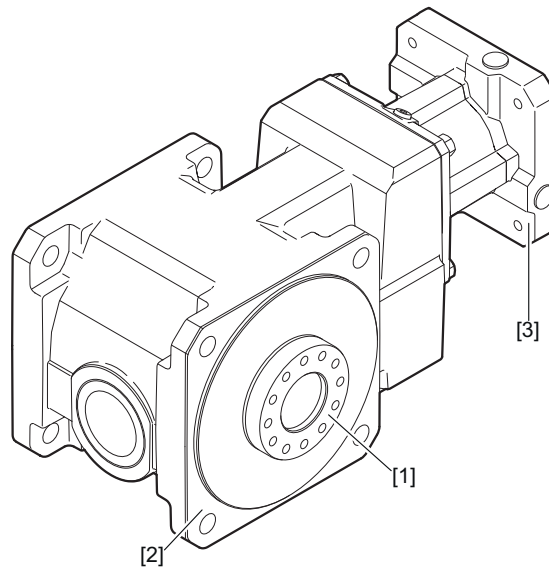

29328910859

- [1] Flange block shaft
- [2] B5 output flange
- [3] EBH.. adapter

3.3 BSHF602 helical-bevel gear unit with EBH.. adapter

The following figure shows an example of a helical-bevel gear unit with hollow shaft and shrink disk as well as B5 output flange.

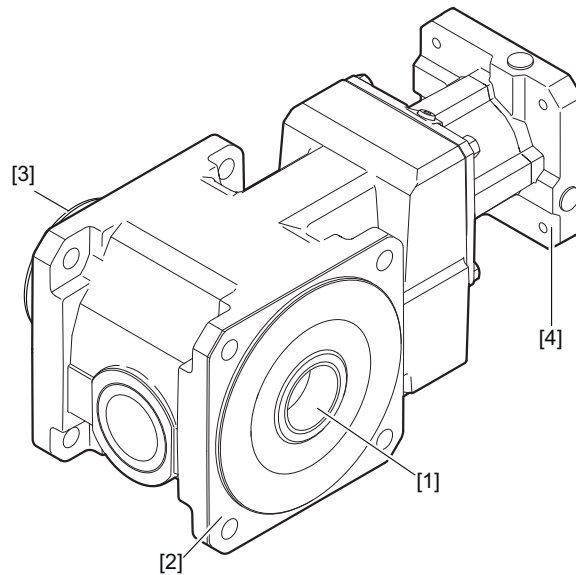

29328915723

- [1] Hollow shaft
- [2] B5 output flange
- [3] Shrink disk
- [4] EBH.. adapter

3.4 BSAF602 helical-bevel gear unit with EBH.. adapter

The following figure shows an example of a gear unit with hollow shaft and keyway as well as B5 output flange:

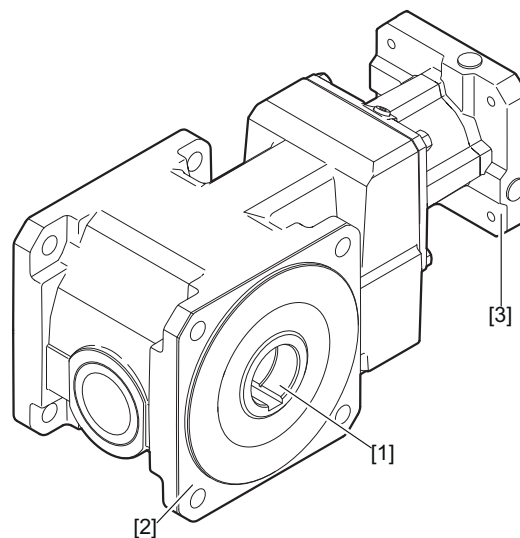

29328907915

- [1] Hollow shaft with keyway
- [2] B5 output flange
- [3] EBH.. adapter

3.5 PSF621 planetary gear unit with EPH.. adapter

The following figure shows a planetary gear unit with solid shaft and B5 output flange:

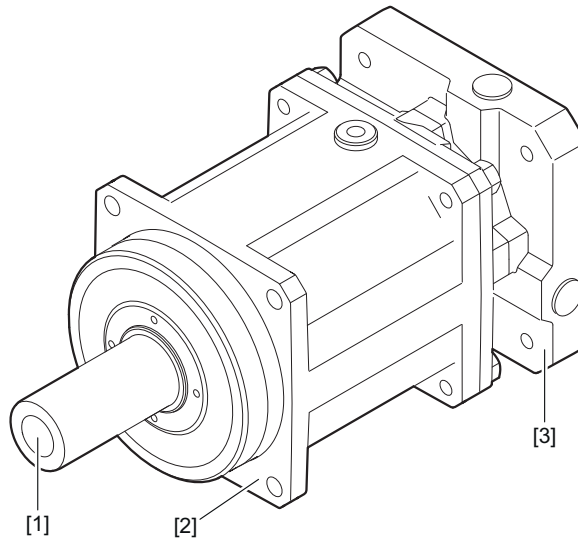

29328938251

- [1] Solid shaft
- [2] B5 output flange
- [3] EPH.. adapter

3.6 PSBF621 planetary gear unit with EPH.. adapter

The following figure shows an example of a planetary gear unit with flange block shaft and B5 output flange.

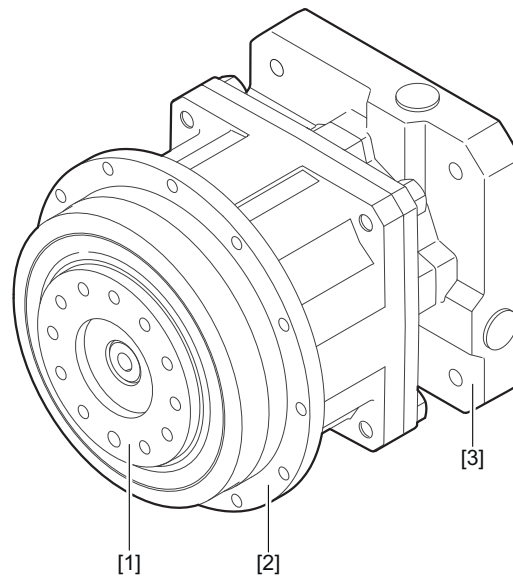

29328918155

- [1] Flange block shaft
- [2] B5 output flange
- [3] EPH.. adapter

3.7 PSC521 planetary gear unit with ECH.. adapter

The following figure shows a planetary gear unit with solid shaft and B5 output flange.

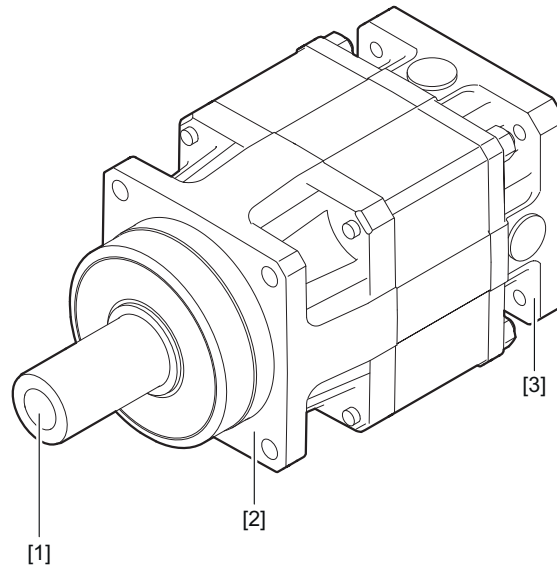

29328933387

- [1] Solid shaft
- [2] B5 output flange
- [3] ECH.. adapter

3.8 PSCZ521 planetary gear unit with ECH.. adapter

The following figure shows a planetary gear unit with solid shaft and B14 output flange.

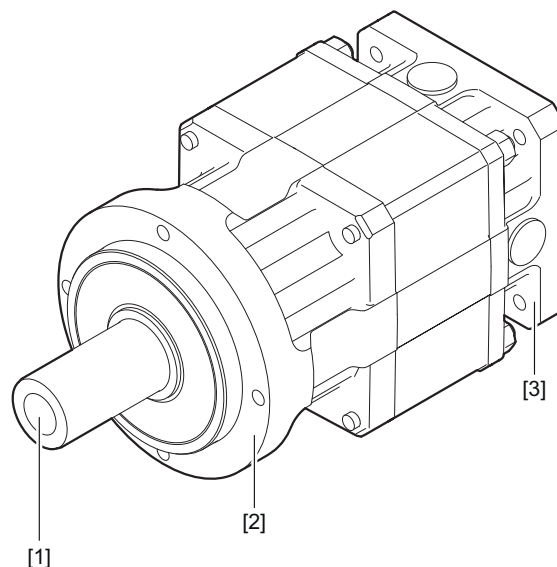

29328935819

- [1] Solid shaft
- [2] B14 output flange
- [3] ECH.. adapter

3.9 Nameplate/type designation

3.9.1 Sample nameplates for planetary gear units PSC.. with adapter ECH..

The following figure shows an example of a 1st nameplate for a PSC.. planetary gear unit with ECH adapter:

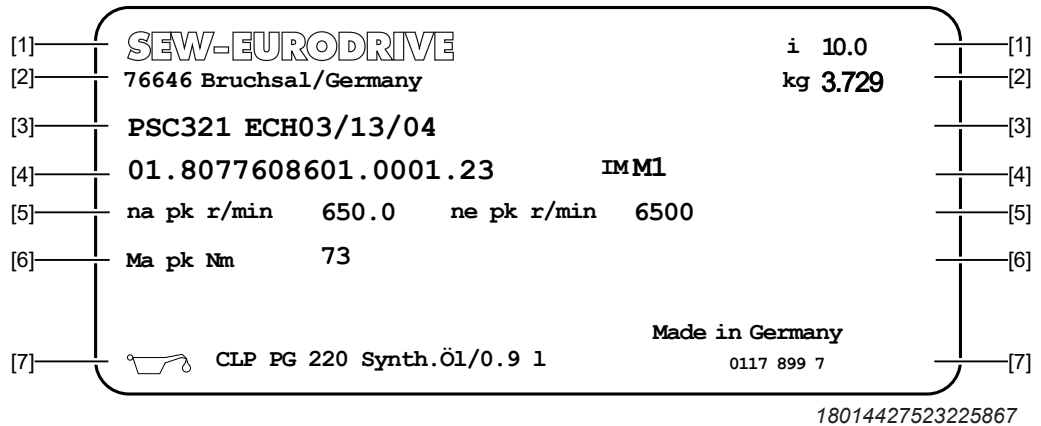

Line	Information
[1]	<ul style="list-style-type: none"> • Manufacturer • Gear ratio
[2]	<ul style="list-style-type: none"> • Address • Weight
[3]	<ul style="list-style-type: none"> • Type designation
[4]	<ul style="list-style-type: none"> • Serial number • Mounting position
[5]	<ul style="list-style-type: none"> • Maximum permitted output speed for short-time duty • Maximum permitted input speed for short-time duty
[6]	<ul style="list-style-type: none"> • Maximum permitted output torque of the gear unit/adapter combination for short-time duty
[7]	<ul style="list-style-type: none"> • Oil type and oil fill volume

The following figure shows an example of a 2nd Nameplate:



	Product label with QR code. The QR code on the product can be scanned. You will be redirected to the Digital Services of SEW-EURODRIVE. There, you have access to product-specific data, documents, and further services.
---	---

3.9.2 Example: Type designation of PSF.. planetary gear unit with EPH.. adapter

A planetary gear unit with adapter, for example has the following type designation:

PSF721 EPH05/14/13		
Gear unit type	PSF	Gear unit
Gear unit size	721	
Adapter designation	EPH	Gear unit component on the input end
Code for performance class	05	
Code for flange geometry (centering, hole circle)	14	
Code for coupling bore	13	

3.9.3 Example: Nameplate of directly mounted PS.F.. servo gearmotor

The figure shows the nameplate of a PS.F.. planetary gear unit with directly mounted servomotor:

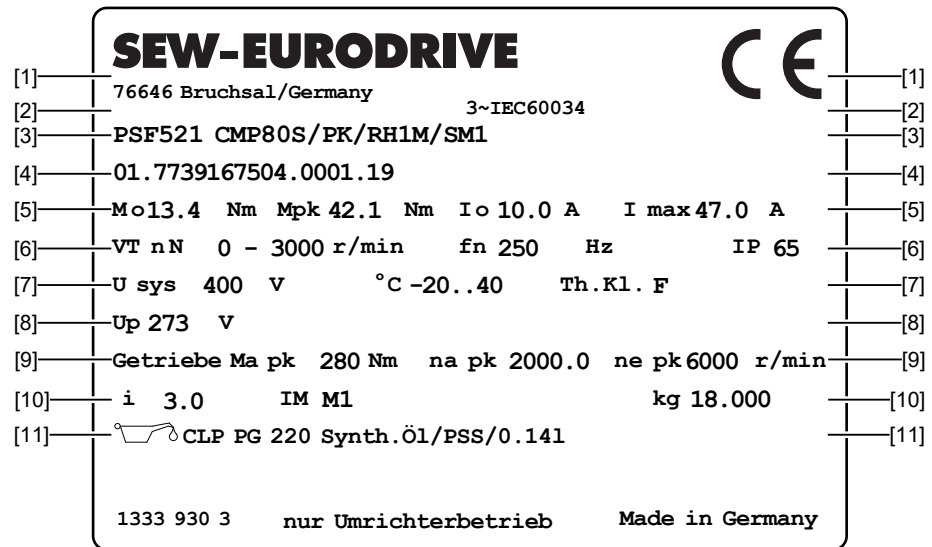

Line	Information
[1]	<ul style="list-style-type: none"> Manufacturer, address CE label
[2]	<ul style="list-style-type: none"> Number of phases and underlying rating and performance standards (EN/IEC 60034-X and/or equivalent national standard)
[3]	<ul style="list-style-type: none"> Type designation
[4]	<ul style="list-style-type: none"> Serial number
[5]	<ul style="list-style-type: none"> Standstill torque Maximum permitted torque for short-time duty Standstill current Maximum permitted current
[6]	<ul style="list-style-type: none"> Rated speed Rated frequency Degree of protection according to IEC 60034-5
[7]	<ul style="list-style-type: none"> System voltage still to be clarified Ambient temperature Thermal class
[8]	<ul style="list-style-type: none"> U_p still to be clarified
[9]	<ul style="list-style-type: none"> Maximum permitted output torque for short-time duty Maximum permitted output speed for short-time duty Maximum permitted input speed for short-time duty
[10]	<ul style="list-style-type: none"> Gear ratio Mounting position Weight
[11]	<ul style="list-style-type: none"> Oil type and oil fill volume

3

Gear unit structure

Nameplate/type designation

3.9.4 Example: Type designation of PS.F.. helical-bevel gear unit with directly mounted CMP.. motor

For example, a helical-bevel servo gearmotor has the following type designation:

PS.F521 CMP80S /PK /RH1M /SM1		
Gear unit type	PSF	Gear unit
Gear unit size	521	
Motor type	CMP	Motor
Motor size	80S	
Temperature sensor	/PK	Motor option
Resolver (standard)	/RH1M	
Plug-in connection for M23 motor	/SM1	

4 Mechanical installation

4.1 Prerequisites for installation



⚠ CAUTION

The surface temperatures on the drive can be very high during operation.

Risk of burns.

- Make sure that hot surfaces cannot be touched unintentionally or during normal operation. Install covers or warning signs according to regulations.
- Let the motor cool down sufficiently before you start working on it.

Ensure that the following requirements have been met:

- The drive has not been damaged during transportation or storage.
- The data on the nameplate of the gear unit matches the requirements.
- Unless the gear unit was designed specifically for liquids, dust, aggressive oils, acids, gases, vapors, or radiation, no contact with these substances is permitted.
- Ensure that no foreign objects (e.g. falling objects or coverings) affect the operation of the gear unit.
- Thoroughly clean the output shafts and the flange surfaces, so that they are free from anti-corrosion agents, dirt, or the like. Do not use compressed air. Use a mild commercially available solvent. Do not expose the sealing lips of the oil seals to the solvent.
- In the case of operation outdoors, the drives must not be exposed to direct sunlight. Install an appropriate protection device, e.g. a cover or a canopy. The protection device must not cause heat build-up.
- Protect the gear unit against icing, because otherwise the seals may suffer damage.
- When the drive is installed in abrasive ambient conditions, protect the output end oil seals against wear.
- Protect the gear unit from cold air flows. Condensed water in the gear unit can cause damage.
- Mount the drive in such a way that sufficient ventilation is guaranteed after installation.
- Make sure that the nameplate is legible after assembly.

4.2 Required tools and resources

- Wrench set
- Torque wrench for:
 - Shrink disks
 - EBH/EPH/ECH motor adapter
- Screwdriver set
- Mounting device
- Compensation elements (washers, spacing rings), if necessary
- Fasteners for input and output elements
- Set of Allen wrenches
- Lubricant (e.g. NOCO® fluid)

4.3 Installation tolerances

Shaft end	Flanges
Diameter tolerance according to DIN 748 <ul style="list-style-type: none"> • ISO k6 for solid shafts with $\varnothing \leq 50$ mm • ISO m6 for solid shafts with $\varnothing > 50$ mm • ISO H7 for hollow shafts • Centering bore according to DIN 332, shape DR 	Centering shoulder tolerance according to DIN EN 50347 <ul style="list-style-type: none"> • ISO j6 with $N \leq 250$ mm • ISO h6 with $N > 250$ mm

4.4 Directions of rotation

4.4.1 Definitions

Direction of rotation of the motor shaft

Clockwise (CW) direction of rotation when looking onto the pinion shaft end of the motor.

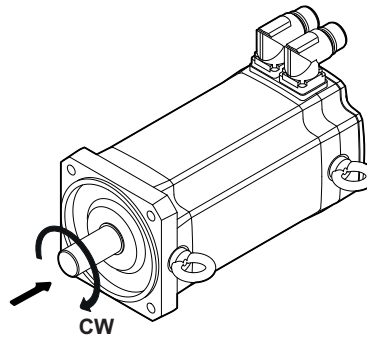

35189045003

Direction of rotation of the output shaft

The standard direction of rotation when looking onto the output shaft of the gear unit:

- CW (clockwise)
Clockwise direction of rotation
- CCW (counterclockwise)
Counterclockwise direction of rotation

Direction of rotation of the output shaft

The standard direction of rotation when looking onto the output shaft of the gear unit:

- CW (clockwise)
Clockwise direction of rotation
- CCW (counterclockwise)
Counterclockwise direction of rotation

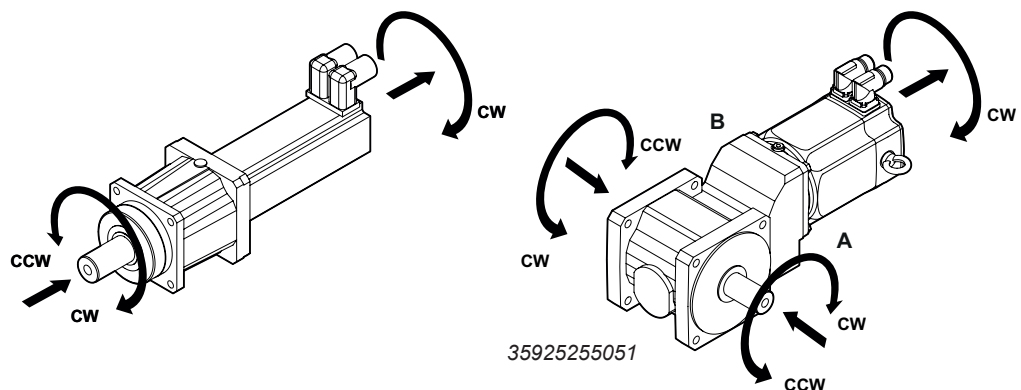

4 Mechanical installation

Directions of rotation

4.4.2 Direction of rotation of the gear unit

Series	Size	Gear unit stages	Shaft position	Standard direction of rotation when looking onto output shaft ¹⁾
PS.C	221 – 622	1		CW
		2		CW
PS.F	121 – 922	1		CW
		2		CW

1) CW = clockwise; CCW = counterclockwise.

Series	Size	Gear unit stages	Shaft position	Standard direction of rotation when looking onto output shaft ¹⁾	
				View onto output end A	View onto output end B
BS.F	202 – 802	2	A	CW	
			AB	CW	CCW
			B		CCW

1) CW = clockwise; CCW = counterclockwise.

4.5 Mounting the gear unit to a machine

- The gear unit or gearmotor may only be installed or mounted in the mounting position ordered (see chapter "Mounting positions") without adaptations. Observe the details on the nameplate (see chapter "Nameplate/type designation").
- Do not brace the gear unit with mounting options on the face and foot ends (BS.F../B) and gear unit flange against one another!
- Observe the permitted overhung and axial forces.
- Once the gear unit or gearmotor has been mounted or installed, the breather valves must be freely accessible!

4.5.1 Bolt sizes

Foot-mounted gear units

The following table shows the thread sizes of the foot-mounted gear units depending on the gear unit type and size:

Screw	Gear unit type BS.F..B
M8	202
M10	302
M12	402/502
M16	602
M20	802

Gear units with B5 flange

The following table shows the thread sizes of the gear units with B5 flange depending on the gear unit type and size:

Screw	Gear unit type			
	BS.F..	PS.F..	PSBF..	PS.C..
M4	–	–	221, 222	–
M5	–	121, 122/221, 222	321, 322/521, 522	221, 222
M6	202	321, 322	621, 622	321, 322
M8	302	521, 522	721, 722/821, 822	521, 522
M10	402	621, 622	–	621, 622
M12	502	721, 722	–	–
M16	602/802	821, 822/921, 922	–	–

Gear unit with B14 flange-mounted design

The following table shows the thread sizes of the gear units with B14 flange depending on the gear unit type and size:

Screw	Gear unit type PS.CZ..
M5	221, 222
M6	321, 322
M8	521, 522
M10	621, 622

4.5.2 Changing the mounting position

If the gear unit or gearmotor is to be installed or mounted in a mounting position other than that ordered and stated on the nameplate, you must undertake the following adaptations:

- Adapt the lubricant fill quantity to suit the new mounting position, see chapter "Lubricants" (→ 59).
- Adapt the position of the breather valve to suit the new mounting position, see chapter "Mounting position sheets".

Contact SEW-EURODRIVE, if necessary.

Change in mounting position for PS.F.. gear unit

In mounting position M2, this position cannot be changed for PS.F.. gear units! Components dependent on the mounting position are fitted in PS.F.. gear units for mounting position M2. One exception is PS.F.. servo gear units in the M0 universal mounting position. These gear units do not have a breather valve (with the exception of PS(K)F 721/22). You can use the PS.F.. gear unit with M0 mounting position in any M1 – M6 mounting position without having to adapt the gear unit.

4.5.3 Customer construction

The customer construction must have the following characteristics:

- Level
- Vibration damping
- Torsionally rigid

The following table states the permitted maximum flatness defect for foot and flange-mounting (guide values based on DIN ISO 1101):

- Gear unit size PS.F/PS.C120 – 520: ≤ 0.2 mm
- Gear unit size PS.F/PS.C620 – 920: ≤ 0.4 mm
- Gear unit size BS.F202 – 402: ≤ 0.4 mm
- Gear unit size BS.F502 – 802: ≤ 0.5 mm

4.5.4 Electrochemical corrosion protection

Electrochemical corrosion occurs between various metals, for example, cast iron and stainless steel. Use plastic inserts (2 – 3 mm thick) if there is a risk of electrochemical corrosion between the gear unit and the driven machine. The material used must have an electrical leakage resistance $< 10^9 \Omega$. If necessary, insert the screws with plastic washers. Use the grounding screws on the motor housing to ground the motor.

4.5.5 Tightening torques for retaining screws

Notes concerning tightening torques

The tightening torques specified in the following chapters are based on the following friction coefficients:

Friction coefficient $\mu_{G,K}$ for thread and head contact surface	Strength class of screw
0.14	8.8
0.09	10.9, 12.9

If screws with a different friction coefficient are used, the tightening torques must be adapted accordingly.

Only use one of the following tools to tighten the screws:

- Torque wrench
- Torque-controlled torque wrench
- Impulse driver, switched off and controlled mechanically
- Torque wrench with light and sound signal
- Motorized torque wrench with dynamic torque measurement
- Torque-controlled, gradual hydraulic tools

Mounting output elements for PSBF.. and BSBF.. gear units

Adhere to the following information when mounting the output elements to the gear unit. Use suitable washers.

Machine screws with hexagon socket head cap screw to DIN EN ISO 4762	Strength class	Tightening torque $\pm 15\%$ Nm
M4	12.9	4.2
M5	12.9	8.3
M6	12.9	14
M8	12.9	35
M10	12.9	68
M12	12.9	117

Mounting of BS.F302/402/602 gear units with B5 flange and BS.F202B – 402B with foot mounting

Mount the gearmotors with the following tightening torques:

Screw/nut	Strength class	Tightening torque $\pm 15\%$ Nm
M8	8.8	28
M10	8.8	56
M12	8.8	96
M16	8.8	235

4 Mechanical installation

Mounting the gear unit to a machine

Mounting of BS.F202/502/802, PS.F.. and PS.C.. gear units with B5 flange, PS.C.. with B14 flange and BS.F502B – 802B with foot mounting

Mount the gearmotors with the following increased tightening torques. Use suitable washers.

Screw/nut	Strength class	Tightening torque $\pm 15\%$ Nm
M4	10.9	3.5
M5	10.9	6.9
M6	10.9	12
M8	10.9	29
M10	10.9	57
M12	10.9	98
M16	10.9	235
M20	10.9	465

Tightening torques for oil level plugs, oil drain plugs, screw plugs, breather valves and oil sight glasses

Observe the tightening torques specified in the following table when screwing:

Thread	Tightening torque Nm
M8 × 1	8
M10 × 1	12
M12 × 1.5	15
M16 × 1.5	40
M22 × 1.5	60
M33 × 2	100
M42 × 2	150

4.5.6 Installation in damp areas or in the open

Drives are supplied in corrosion-resistant designs with a suitable surface protection coating for use in damp areas or outdoors. Repair any damage to the paint work (e.g. on the breather valve or the lifting eyes).

When mounting motors via adapters, seal the flange areas with a suitable sealant, e.g. Loctite® 574.

Units installed outdoors must be protected from the sun. Suitable protective devices are required, such as covers or roofs. Avoid heat from building up. The user must ensure that foreign objects do not impair the function of the gear unit (e.g. falling objects or coverings).

4.5.7 Gear unit venting

Upon delivery, the breather valve for gear units with a pivoted mounting position and gear units for mounting skew can be found in the motor's terminal box. Before startup, replace the highest screw plug with the provided breather valve.

In the M4 mounting position, the BS.F202-802/PS.F722 gear units require venting.

In the M4 mounting position, the BS.F/PS.F722 servo gear units have a screwed-in and activated breather valve in the delivery state.

Activating the breather valve

1. Before startup, check whether the transport protection on the breather valve has been removed and the valve is therefore activated. The following figure shows a breather valve with transport protection:

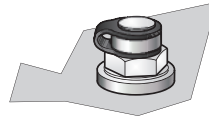

2. Remove the transport protection.

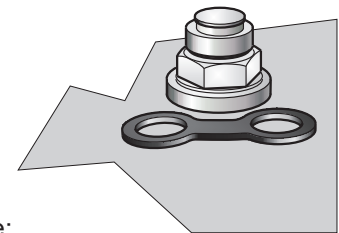
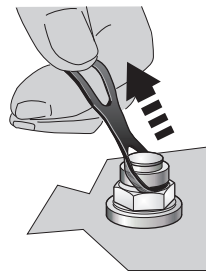

⇒ The following figure shows an activated breather valve:

4.5.8 Painting gear units**NOTICE**

Breather valves and oil seals may be damaged when painting or re-painting.

Possible damage to property.

- Thoroughly cover the breather valves and the sealing lip of the oil seals with strips prior to painting.
 - Remove the strips after painting.
-

If you want to paint the gear unit, check that the new paint is compatible with the existing protective varnish. Using incompatible paints can result in damage to the paint work. Thus, the protective function of the paint is no longer ensured.

4.6 Installation in a machine: BS.F.. helical-bevel gear units

Note the following minimum screw-in depths into the gear unit's output flange:

Gear unit	Minimum screw-in depth
BS.F..202B – 402B	1.6 × screw diameter
BS.F..502B – 802B	1.25 × screw diameter

For screw sizes and tightening torques, refer to chapter "Tightening torques for retaining screws" (→ 27).

4.6.1 BS.F... Bolted from the gear unit end via the B5 flange:

The following figure shows the installation of BS.F.. helical-bevel gear units:

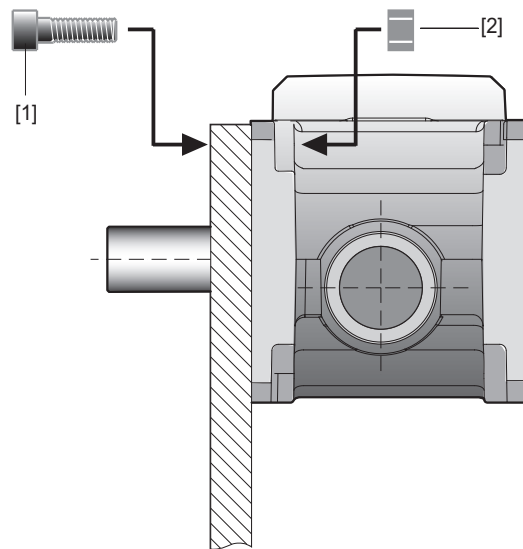

1839202059

- [1] Screws
- [2] Nut

4

Mechanical installation

Installation in a machine: BS.F.. helical-bevel gear units

4.6.2 BSBF..B: Screw fitting at the foot and front end

The following figure shows foot-mounting of BSBF..B helical-bevel gear units:

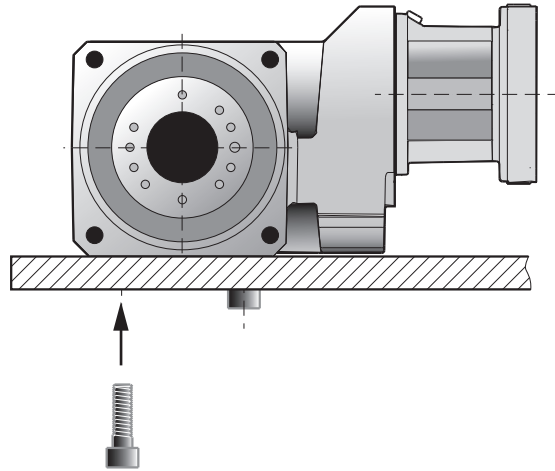

1839204747

The following figure shows front-mounting of BSBF..B helical-bevel gear units:

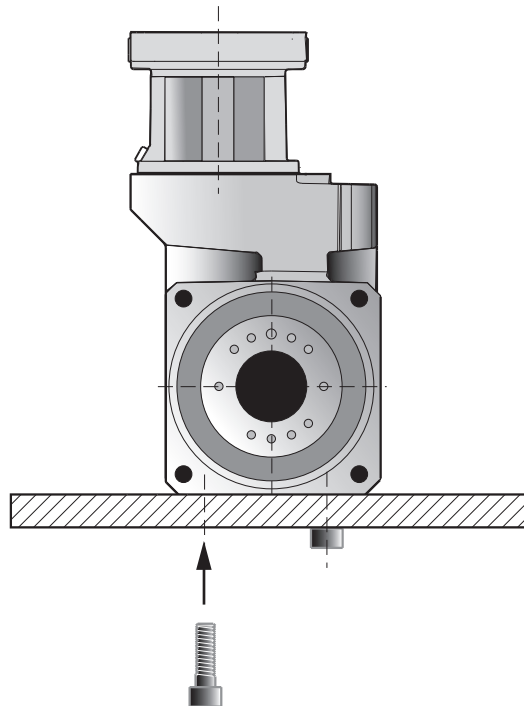

1839207435

Observe the following minimum screw-in depths:

Gear unit	Minimum screw-in depth
BS.F..202B – 402B	1.6 × screw diameter
BS.F..502B – 802B	1.25 × screw diameter

For screw sizes and tightening torques, refer to chapter "Tightening torques for retaining screws" (→ 27).

31544835/EN – 09/2023

4.7 Installation in a machine: PS.F.. planetary gear units

4.7.1 PS.F... Bolted from the gear unit end via the B5 flange:

The following figure shows the installation of PS.F.. planetary gear units:

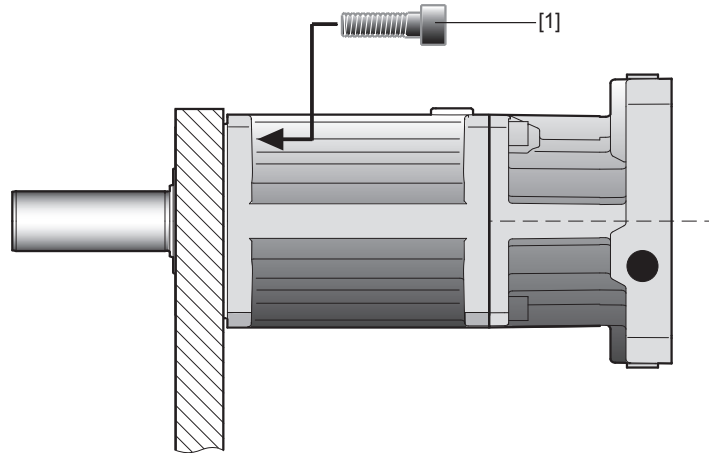

1881669387

[1] Screws

4

Mechanical installation

Installation in a machine: PS.C.. planetary gear units

4.8 Installation in a machine: PS.C.. planetary gear units

4.8.1 PS.C..: Bolted from the gear unit end via the B5 flange

The following figure shows the installation of PS.C.. planetary gear units:

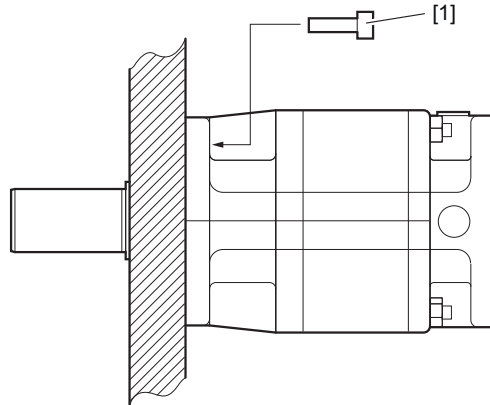

35936063115

[1] Screws

4.8.2 PS.CZ..: Bolted from the gear unit end via the B14 flange

The following figure shows the installation of PS.CZ.. planetary gear units:

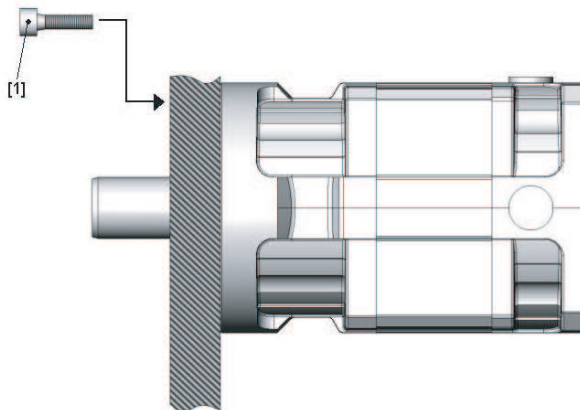

9007201140895243

[1] Screws

Note the following minimum screw-in depth into the gear unit's output flange:

Gear unit	Minimum screw-in depth
PS.CZ..	1.6 × screw diameter

4.9 Mounting the output elements to the output shaft

4.9.1 Mounting the gear unit – solid shaft design with key

- Use a mounting device for installing input and output elements if possible. Use the centering bore and the thread on the shaft end for positioning.
- Push all mount-on components (belt pulleys, couplings, pinions etc.) onto the shaft end without force.
- When installing the belt pulleys, make sure the belt is tensioned correctly in accordance with the manufacturer's instructions.
- Make sure the mounted transmission elements are balanced to prevent impermissible radial or axial forces.

INFORMATION



In the BSF.. /BSKF.. / PSF.. / PSKF.. / PS.C.. / PSKC.. / PS.CZ.. / PSKCZ.. series, you can use the shaft shoulder [1] as the defined attachment point when mounting input and output elements.

The following figure shows a sample mounting device for mounting couplings [3] or hubs onto motor or gear shaft ends. It may be possible to dispense with the thrust bearing [2] on the mounting device.

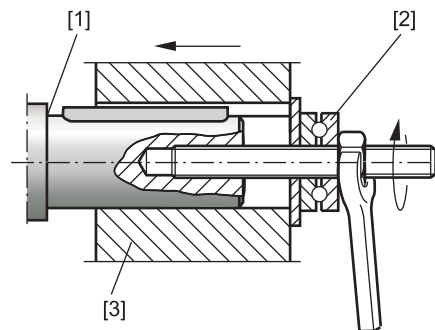

1839217419

- | | |
|-----|----------------|
| [1] | Shaft shoulder |
| [2] | Thrust bearing |
| [3] | Coupling hub |

In the delivery state, the output shafts are already coated with a rust preventive agent. Remove the rust preventive before mounting.

4

Mechanical installation

Mounting the output elements to the output shaft

Avoiding high radial loads

To avoid high radial loads, mount gear wheels and sprockets according to figure B.

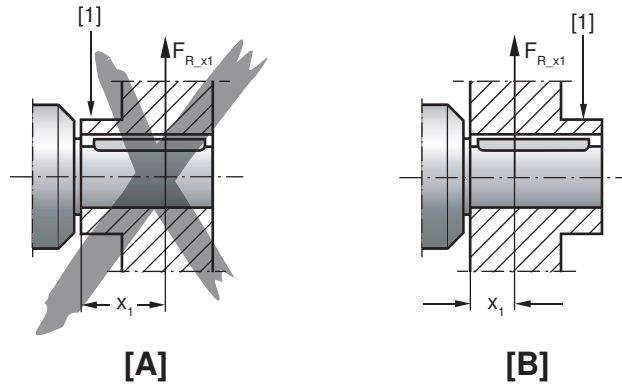

9007199466105227

[1] Hub
[A] Incorrect assembly

$F_{R,x1}$ Radial load at position x_1
[B] Correct assembly

4.9.2 Mounting the gear unit – smooth solid shaft design

▲ CAUTION

Insufficient shaft-hub connection with the use of clamping sets on a smooth shaft end due to greasy or dirty shaft.

Malfunction.

- Make sure the clamping area [5] is free of dirt and grease. Otherwise, the shaft-hub connection may not function properly.

INFORMATION



The shaft collar [1] can be used as defined stop for mounting output elements onto the solid shaft.

The following figure shows an example of shaft assembly with inner clamping set:

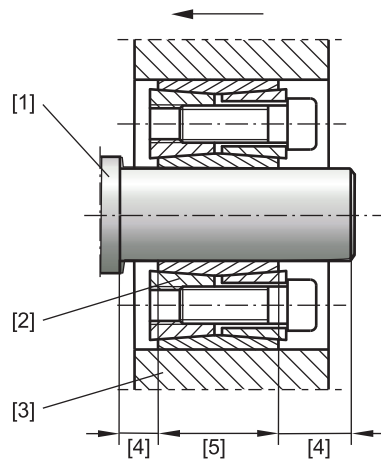

1839232907

- [1] Shaft shoulder
- [2] Clamping set
- [3] Output element, e. g. gear or sprocket
- [4] Greased shaft areas
- [5] Ungreased clamping area

Grease accessible areas [4] of the shaft after mounting.

4 Mechanical installation

Mounting of couplings

4.9.3 Flange block shaft assembly

INFORMATION



Mounting is easier if you first apply lubricant to the drive component or heat it up briefly (to 80 – 100 °C).

The following figure shows the correct mounting arrangement of a shaft connection in combination with an inner and outer centering ring using the example of a BSBF... flange block:

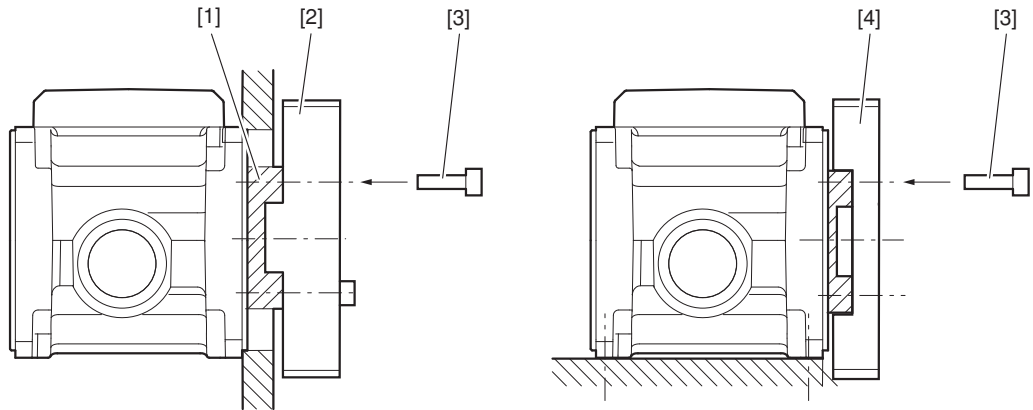

35936066443

- [1] BSBF... flange block
- [2] Gear wheel/belt pulley with inner centering ring
- [3] Bolts of strength class 12.9
- [4] Gear wheel/belt pulley with outer centering ring

4.10 Mounting of couplings

Adjust the following misalignments according to the coupling manufacturer's specifications when mounting couplings.

- 1) Axial misalignment
- 2) Radial misalignment
- 3) Angular misalignment

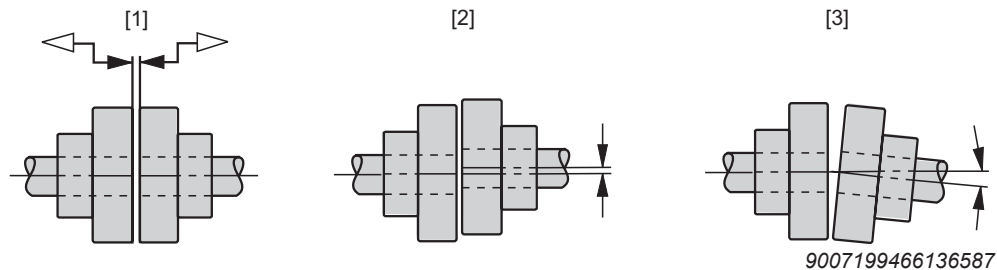

9007199466136587

4.11 Installing a torque arm on BS.F.. shaft-mounted gear units

Mount the torque arm without any stress!

The following illustration shows the possible torque arm positions for BS.F.. gear units:

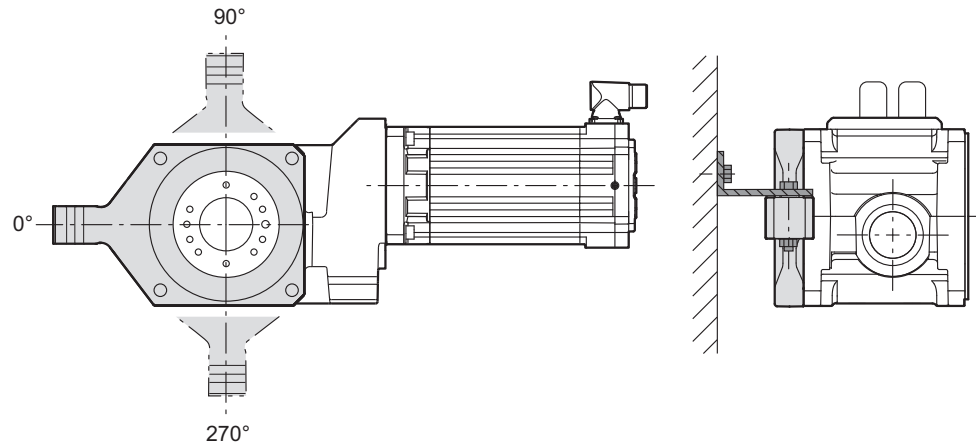

1839381771

With aluminum parts, use suitable tooth lock washers.

Tighten the retaining screws according to the following table:

Gear unit size	Number of screws × screw size ¹⁾	Tightening torque Nm
202	4 × M6 × 35 – 8.8	12
302	4 × M8 × 40 – 8.8	28
402	4 × M10 × 45 – 8.8	56
502	4 × M12 × 40 – 8.8	96
602	4 × M16 × 55 – 8.8	235
802	4 × M16 × 55 – 8.8	235

1) strength class according to DIN EN ISO 4762

4 Mechanical installation

Mounting shaft-mounted gear units with a keyway

4.12 Mounting shaft-mounted gear units with a keyway

INFORMATION



Wherever possible, use a mounting device.

1. Apply NOCO® fluid and distribute it thoroughly.

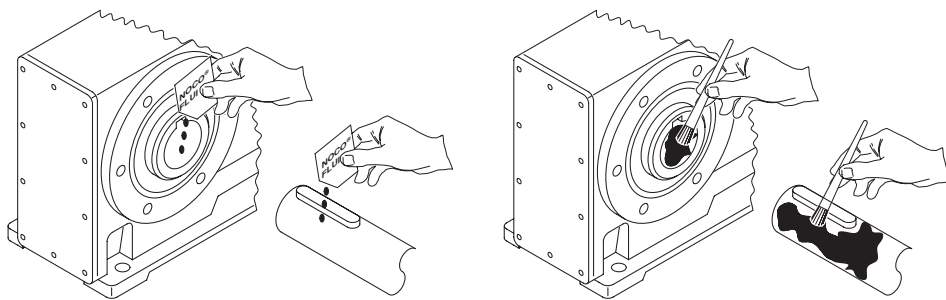

2. Install the shaft and secure it axially.

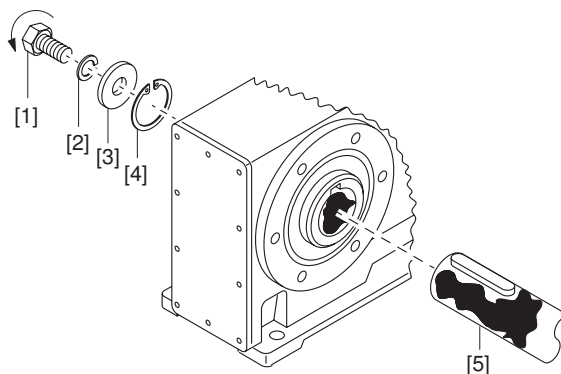

- [1] Short retaining screw (standard scope of delivery)
- [2] Lock washer
- [3] Washer
- [4] Retaining ring
- [5] Customer shaft

3. Tighten the retaining screw using the appropriate torque:

Screw	Tightening torque in Nm
M5	5
M6	8
M10, M12	20
M16	40
M20	80
M24	200

4.13 Shaft-mounted gears unit with shrink disk

4.13.1 Mounting shaft mounted gear units with shrink disk



NOTICE

Deformation of the hollow shaft due to tightening the locking screws without first installing the shaft.

Gear unit damage.

- Never tighten the locking screws without the shaft installed.

INFORMATION



The exact values for the tightening torques are shown on the shrink disk.

INFORMATION



Standard shrink disks and stainless steel shrink disks have the same tightening torques.

1. Slightly loosen the locking screws. Do not screw them completely out.

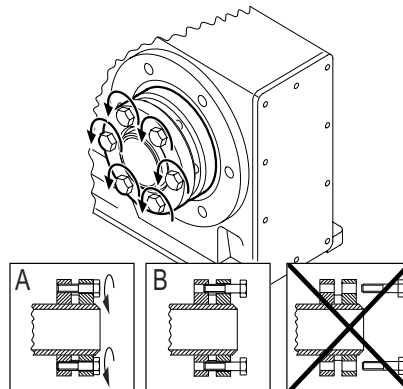

9007199466274571

4

Mechanical installation

Shaft-mounted gears unit with shrink disk

- Carefully **degrease** the hollow shaft bore and the input shaft with commercially available solvent.

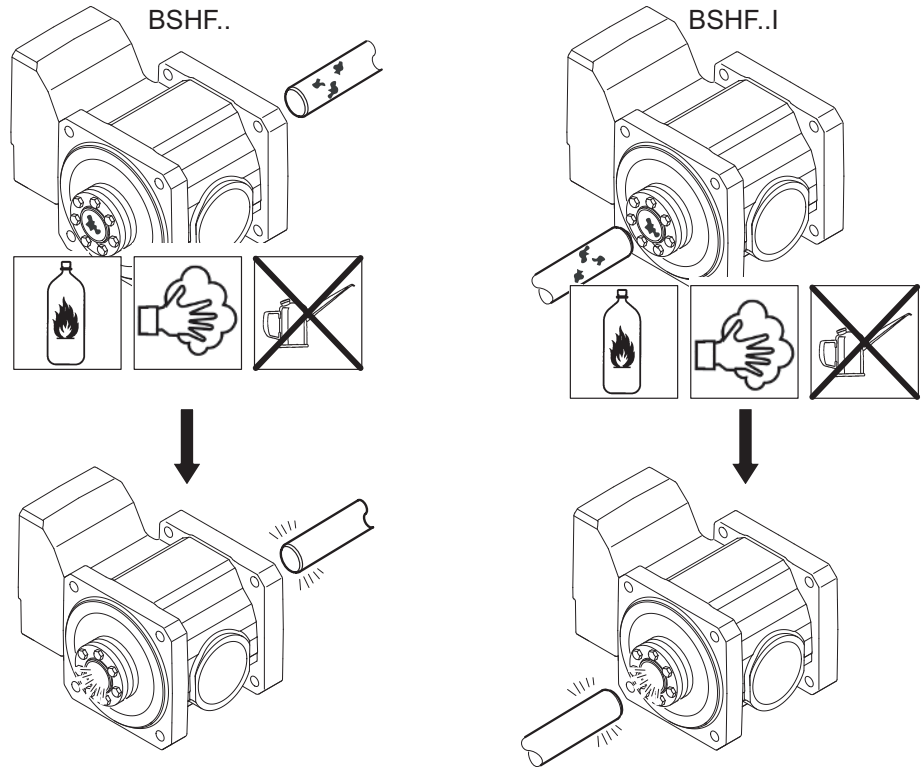

9007201093985035

- CAUTION!** Never apply NOCO® fluid directly onto the bushing, since the compound can get into the clamping area of the shrink disk when the machine shaft is fitted.

Apply NOCO® fluid to the machine shaft in the vicinity of the bushing. The clamping area of the shrink disk must remain free of grease!

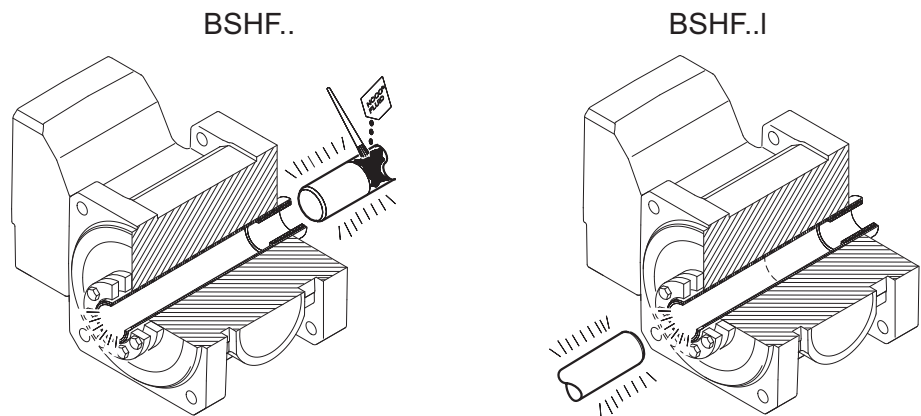

9007201094021387

- CAUTION!** Risk of injury due to falling shrink disk. Secure the shrink disk immediately after fitting the shaft.
- Install the input shaft. Make sure that the outer rings of the shrink disk are plane-parallel.
- For a gear unit with a shaft shoulder, fit the shrink disk to the shaft shoulder as far as it will go, whereby the minimum distance between the outer ring of the shrink disk facing the gear unit and the gear unit housing must be no less than 2 mm.

7. For a gear unit without shaft shoulder, mount the shrink disk at a distance of 2 to 3 mm from the gear unit housing.
8. Tighten the locking screws by working round several times from one screw to the next (not in diametrically opposite sequence). The tightening torques can be found in the following table. After installation, grease the outer surface of the hollow shaft in the vicinity of the shrink disk as corrosion protection.

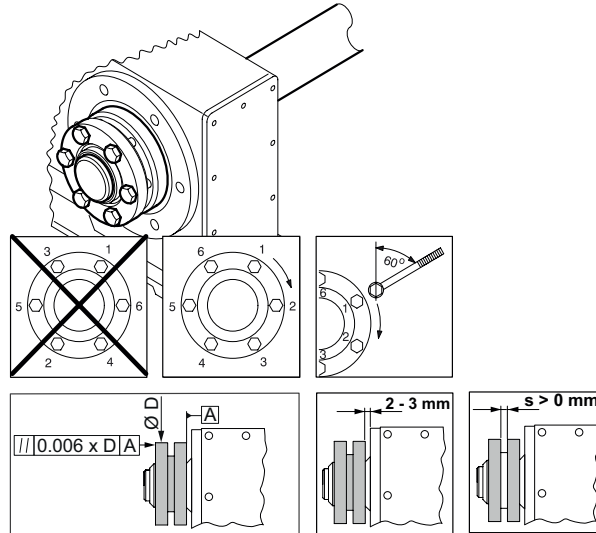

9007199466283275

9. After installation, make sure the remaining gap "s" between the outer rings of the shrink disk is > 0 mm. Observe the table of tightening torques below.
10. To prevent corrosion, grease the outer surface of the hollow shaft around the shrink disk.
11. **⚠ CAUTION!** Install the provided rotating safety cover or another, suitable safety cover at the shrink disk to prevent injuries. Never start up the drive if the protective covers are not installed.

Gear unit type	Locking screw ISO 4014/ISO 4017/ ISO 4762	Tightening torque
BSHF202	M5	5
BSHF302	M5	5
BSHF402	M6	12
BSHF502	M6	12
BSHF602	M6	12
BSHF802	M8	30

4.13.2 Removing shaft-mounted gear units with shrink disk

INFORMATION



There is no need to dismantle clean, removed shrink disks before they are reinstalled.

1. **▲ CAUTION!** Risk of injury due to falling shrink disk. Secure the shrink disk before disassembly.
2. To prevent the outer rings from jamming, loosen the locking screws a quarter turn, one after the other.
3. Steadily loosen the locking screws one after the other, but do not remove the locking screws completely.
4. If rust has formed on the shaft in front of the hub, remove the rust.
5. Remove the shaft or pull the hub off the shaft.
6. Remove the shrink disk from the hub.

4.13.3 Cleaning and lubricating the shrink disk

If a removed shrink disk is clean, it does not have to be disassembled or re-greased before re-tightening.

The shrink disk only needs to be cleaned and greased if it is contaminated.

Use one of the following solid lubricants for the tapered surfaces:

Lubricant (Mo S ₂)	Sold as
Molykote® 321 (lube coat)	Spray
Molykote® spray (powder spray)	Spray
Molykote® G Rapid	Spray or compound
Aemasol® MO 19P	Spray or compound
Aemasol® DIO setral 57 N (lube coat)	Spray

Grease the locking screws with a multipurpose grease such as Molykote® BR 2 or a similar grease.

4.14 Mounting the motor on a gear unit using an adapter

4.14.1 Mounting motor via EBH.. and EPH.. adapters

The following figure illustrates motor mounting via EPH.. adapter:

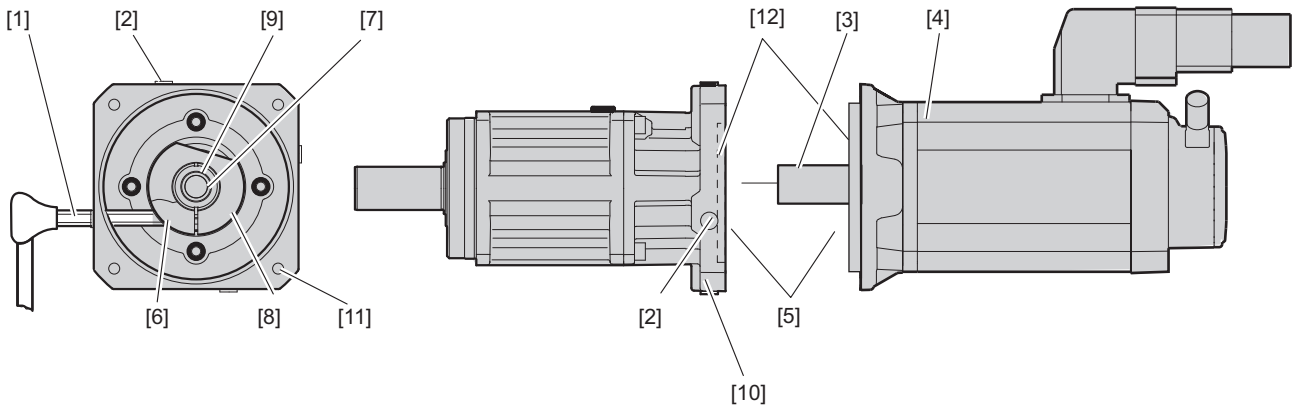

35869024139

[1] Torque wrench	[7] Coupling sleeve
[2] Closing plug	[8] Clamping ring
[3] Motor shaft	[9] Adapter shaft
[4] Motor	[10] EPH adapter
[5] Flange contact surfaces	[11] Connection bores
[6] Clamping screw	[12] Flange centerings

- ✓ As far as possible, attach the motor in vertical direction with the motor at the top. You can perform the assembly in a different location only if the application or space circumstances do not permit the standard position.
 - ✓ To avoid tensions due to misalignments, you must support the motor and align the motor shaft.
 - ✓ The motor must demonstrate at least true-running, face runout, and coaxiality accuracy level "N" to DIN 42955.
1. **▲ WARNING!** Risk of injury if the drive starts up unintentionally. Severe or fatal injuries. Disconnect the drive from the power supply before you start work. Prevent the drive from starting up unintentionally, for example by locking the key switch or removing the fuses from the current supply. Set up a caution sign to warn that it is forbidden to switch the drive on.
 2. Check the flange contact surfaces [5] of the motor and adapter for possible scoring and smoothen them if necessary.
 3. Clean, degrease and dry the following drive components. Use a degreasing, non-aggressive cleaning agent:
 - ⇒ The hollow shaft bore of the adapter shaft [9]
 - ⇒ The coupling sleeve [7] (if available)
 - ⇒ The motor shaft [3]
 - ⇒ The flange contact surfaces of motor and adapter [5]
 - ⇒ The flange centering of motor and adapter [12]
 4. Remove one of the 4 closing plugs [2].

4 Mechanical installation

Mounting the motor on a gear unit using an adapter

5. For motors without a keyway: Turn the adapter shaft [9] with clamping ring [8] until the screw head of the clamping screw [6] can be accessed via the mounting bore. Loosen the clamping screw [6] by 1 turn.
6. For motors with a keyway: SEW-EURODRIVE recommends to insert a half keyway into the keyway to compensate imbalance. The half keyway must not protrude out of the groove in the motor shaft extension. Turn the keyway by 90° to the slots in the adapter shaft [9].
7. When using coupling sleeves [7], make sure to align the slots in the coupling sleeve [7], the adapter shaft [9] and the clamping ring [8].
8. Carefully and without using force, insert the motor shaft [3] into the hollow shaft bore of the adapter shaft [9] until the flange contact surfaces [5] of motor and adapter touch. There must be no gap between the flange contact surfaces. The connection bores [11] must be aligned.
9. Insert the connecting screws into the tapped holes of the adapter flange [11] via the through bores of the motor flange. Evenly tighten the screws in diametrically opposite sequence with increasing torque. Use the tightening torques stated in the table below "Tightening torques for mounting EPH../EBH.. adapters with motor" and observe the information provided in chapter "Information relating to tightening torques" (→ 27).
10. Use a suitable torque wrench [1] to tighten the clamping screw [6]. Use the tightening torques stated in the table below "Tightening torques for clamping screws".

Tightening torques for mounting EPH/EBH adapters with motor

Screw size	Strength class	Tightening torque ±15% Nm
M4	8.8	3.4
M5	8.8	6.8
M6	8.8	12
M8	8.8	28
M10	8.8	56
M12	8.8	96
M16	8.8	235

Tightening torques for clamping screws

Adapter type	Motor shaft diameter mm	Number of clamping screws	Clamping screw tightening torque Nm	Wrench size
EBH03	≤ 14	1	18	5
EBH04	≤ 19	1	18	5
EBH05	≤ 24	1	43	6
EBH06	≤ 35	1	43	6
EBH07	≤ 35	1	43	6
EBH08	≤ 38	1	83	8
EBH09	≤ 42	1	83	8
EBH10	≤ 55	1	145	10
EPH01	≤ 11	1	10	4
EPH02	≤ 14	1	18	5
EPH03	≤ 14	1	18	5

31544835/EN – 09/2023

Adapter type	Motor shaft diameter mm	Number of clamping screws	Clamping screw tightening torque Nm	Wrench size
EPH04	≤ 19	1	18	5
EPH05	≤ 24	1	43	6
EPH06	≤ 35	1	43	6
EPH07	≤ 32	1	43	6
EPH08	≤ 38	1	83	8
EPH09	≤ 42	1	83	8
EPH10	≤ 55	1	145	10

4 Mechanical installation

Mounting the motor on a gear unit using an adapter

4.14.2 Motor mounting via ECH.. adapter

The following figure illustrates motor mounting via ECH.. adapter:

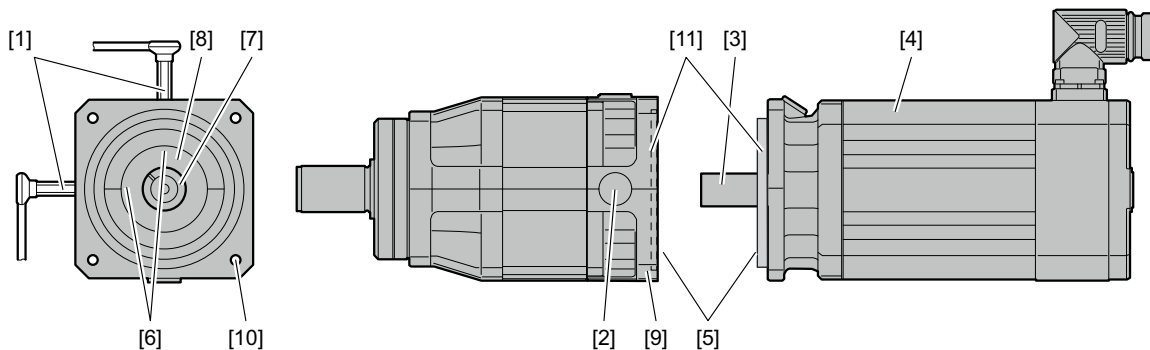

9007236284455179

- | | |
|-----------------------------|------------------------|
| [1] Torque wrench | [6] Clamping screws |
| [2] Closing plug | [7] Motor shaft sleeve |
| [3] Motor shaft | [8] Adapter shaft |
| [4] Motor | [9] ECH.. adapter |
| [5] Flange contact surfaces | [11] Connection bores |
| | [12] Flange centerings |

- ✓ As far as possible, attach the motor in vertical direction with the motor at the top. You can perform the assembly in a different location only if the application or space circumstances do not permit the standard position.
 - ✓ To avoid tensions due to misalignments, you must support the motor and align the motor shaft.
 - ✓ The motor must demonstrate at least true-running, face runout, and coaxiality accuracy level "N" to DIN 42955.
1. **⚠ WARNING!** Risk of injury if the drive starts up unintentionally. Severe or fatal injuries. Disconnect the drive from the power supply before you start work. Prevent the drive from starting up unintentionally, for example by locking the key switch or removing the fuses from the current supply. Set up a caution sign to warn that it is forbidden to switch the drive on.
 2. Check the flange contact surfaces [5] of the motor and adapter for possible scoring and smoothen them if necessary.
 3. Clean, degrease and dry the following drive components. Use a degreasing, non-aggressive cleaning agent:
 - ⇒ The hollow shaft bore of the adapter shaft [8]
 - ⇒ The motor shaft sleeve [7]
 - ⇒ The motor shaft [3]
 - ⇒ The flange contact surfaces of motor and adapter [5]
 - ⇒ The flange centering of motor and adapter [12]
 4. Remove the 2 closing plugs [2].
 5. For motors without a keyway: Loosen the clamping screws [6] until both screws project around 3 threads into the mounting hole of the adapter.
 6. For motors with a keyway: SEW-EURODRIVE recommends to insert a half keyway into the keyway to compensate imbalance. The half keyway must not protrude out of the groove in the motor shaft extension. Turn the keyway to align with the slot in the motor shaft sleeve [7].

31544835/EN – 09/2023

7. Make sure that the slot of the motor shaft sleeve [7] is at a 45° angle to the two clamping screws [6].
8. Carefully and without using force, insert the motor shaft [3] into the hollow shaft bore of the adapter shaft [9] until the flange contact surfaces [5] of motor and adapter touch. There must be no gap between the flange contact surfaces. The connection bores [11] must be aligned.
9. Carefully push the gear unit and motor [4] together.
10. Push the connection screws through the through holes of the motor flange. Turn the screws into the threaded holes of the adapter flange and tighten them slightly.
11. Tighten the screws diagonally with even force. Use the tightening torques stated in the table below "Tightening torques for mounting ECH.. adapter with motor". Also consult chapter "Information relating to tightening torques" (→ 27).
12. Use a suitable torque wrench [1] to first tighten the clamping screws [6] one after the other to 25% of the stipulated tightening torque. In a second step, tighten them to the full torque. Use the tightening torques stated in the table below "Tightening torques for clamping screws".

Tightening torques for mounting ECH.. adapter with motor

Screw size	Strength class	Tightening torque ±15% Nm
M4	8.8	3.4
M5	8.8	6.8
M6	8.8	12
M8	8.8	28
M10	8.8	56

Tightening torques for clamping screws

Adapter type	Motor shaft diameter mm	Number of clamping screws	Clamping screw tightening torque Nm	Wrench size
ECH02	≤ 11	2	10	4
ECH03	≤ 14	2	23	5
ECH05	≤ 19	2	45	6
ECH06	≤ 24	2	100	8

4

Mechanical installation

Mounting the motor on a gear unit using an adapter

4.14.3 Permitted motor weight with adapter EBH.., EPH.., ECH...

The following diagram shows the permitted distance x from the motor center of mass to the adapter flange depending on the permitted motor weight:

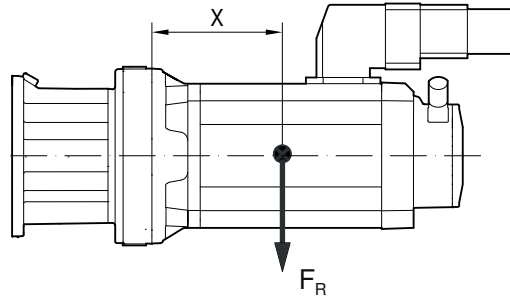

30475608331

- ⊗ Motor center of mass
- x Distance between adapter flange and motor center of mass
- F_R Permitted overhung load

BSF.. EBH..

Adapter type EBH..	$x^{1)}$ mm	$F_R^{1)}$ N
EBH03/01-14	182	157
EBH04/12-15	182	157
EBH05/14-20 EBH05/26	220	273
EBH06/19	290	312
EBH07/20-22 EBH07/27-28	290	312
EBH08/21-22	351	600
EBH09/22-25	400	680
EBH10/22-25	400	680

PSF.. EPH..

Adapter type EPH..	$x^{1)}$ mm	$F_R^{1)}$ N
EPH01/01-03	100	120
EPH02/04-13	120	150
EPH03/01-14	182	157
EPH04/01-15	182	157
EPH05/14-20 EPH05/26	220	273
EPH06/19	290	312
EPH07/20-22 EPH07/27-28	290	312
EPH08/21-22	351	600
EPH09/22-25	400	680

31544835/EN – 09/2023

PS.C.. ECH..

Adapter type EPH..	x ¹⁾ mm	F _R ¹⁾ N
EPH10/22-25	400	680

Adapter type ECH..	x ¹⁾ mm	F _R ¹⁾ N
ECH02/01	90	40
ECH02/08	130	94
ECH03/08	130	94
ECH03/13	155	170
ECH05/13	155	170
ECH05/14	200	306
ECH06/14	200	306
ECH06/20	235	530

PS.C.. EPH..

Adapter type EPH..	x ¹⁾ mm	F _R ¹⁾ N
EPH01/01-03	100	120
EPH02/04-08	120	150
EPH03/01-14	182	157
EPH04/01-15	182	157
EPH05/14-20	220	273
EPH05/26	220	273
EPH06/19	290	312
EPH07/20-22	290	312
EPH07/27-28	290	312
EPH08/21-22	351	600

1) Maximum load values for connection screws of strength class 8.8. If the center of gravity distance x increases, the maximum permitted weight F_R of the attached motor must be reduced linearly. If the center of gravity distance x decreases, the maximum permitted weight F_R must not be increased.

4.14.4 Mounting motors to gear units directly

NOTICE

Mounting the motor to the gear unit may cause malfunctions.

Possible fault

- Never mount a motor directly to the gear unit.



4.15 Removing the motor from the adapter

NOTICE

If the customer removes an adapter from the gear unit, there is a risk of damage to the gear unit.

Gear unit damage.

- The customer must never remove an adapter from a gear unit.
-

NOTICE

If the customer removes an adapter from a gear unit directly mounted on the motor, there is a risk of damage to the gear unit.

Gear unit damage.

- The customer must never remove a directly mounted gear unit from a motor.
-

4.15.1 Sequence for demounting the motor from adapter EBH.., EPH.. or ECH..

Adhere to the following sequence during disassembly of the EBH.. adapter:

1. Switch off the drive
2. Secure the load
3. Turn off the current to the motor
4. Allow the drive to cool
5. Unscrew the clamping screws
6. Unscrew the connection screws between the motor and adapter
7. Remove the motor without tilting or jamming it

5 Startup

Switch off the gearmotor if in doubt whenever changes occur in relation to normal operation, e.g. noises or vibrations. Determine the cause of the fault and, if necessary, contact SEW-EURODRIVE.

Gear units with motor adapter

For gear units with an adapter, you must ensure that the data specified on the nameplate and in the project planning documents for the gear unit are not exceeded. It is essential that the gear unit is not overloaded.

Inverter-operated gearmotors

The parameter settings made for the inverter must prevent the gear unit from being overloaded. Refer to the nameplate and the project planning documents for the correct gear unit data.

5.1 Design-related special features

5.1.1 BS.F.. helical-bevel gear units for mounting position M5

INFORMATION



With mounting position M5, it is important that you only operate the gear unit at a maximum of 50% of the limit speed for the first 24 hours of operation.

5.1.2 PSF../PSKF.. planetary gear units for mounting position M2

INFORMATION



With mounting position M2, it is important that you only operate the gear unit at a maximum of 50% of the limit speed for approx. the first 24 operating hours.

5.2 Measuring the surface temperature

It is essential to measure the surface temperature at the maximum loading condition when starting up the gear unit. Commercially available thermometers can be used to measure the temperature.

Measure the surface temperature at the joint between gear unit and adapter or motor. The maximum surface temperature is reached after approx. 3 hours. It must not exceed a value of 95 °C.

6 Inspection and Maintenance

6.1 Preliminary work regarding gear unit inspection/maintenance

Observe the following notes before you start with the inspection/maintenance work.

- Observe the 5 safety rules before commencing the work: Disconnect. Secure the device against a restart. Check that no voltage is applied. Ground and short-circuit it. Cover or cordon off neighboring live parts.
- Let the unit cool down sufficiently before you start working on it.
- Before releasing shaft connections, make sure that there are no active torsional moments present (tensions within the system).
- Do not mix different synthetic lubricants and do not mix synthetic and mineral lubricants.

INFORMATION



The position of the breather valve depends on the mounting position. Refer to the diagrams of the mounting positions. See chapter "Mounting positions".

- Prevent foreign particles from entering into the gear unit during maintenance and inspection work.
- Do not clean the gear unit with a high-pressure cleaning device. Water might enter the gear unit and the seals might be damaged.
- Perform safety and functional checks following all maintenance and repair work.

6.2 Inspection and maintenance intervals

INFORMATION



Maintain the inspection and maintenance intervals. This is necessary to ensure operational safety.

Time interval	What should I do?
<ul style="list-style-type: none"> 500 operating hours or 3 months after startup 	<ul style="list-style-type: none"> Visual check for external damage and leakage at the seals. Check the tightening torque of the clamping screw for the clamping ring. For the applicable tightening torque, refer to the table "Tightening torques for clamping screws" or to the clamping ring. Check the tightening torques of the screw connections between the gear unit and the machine and between the output elements and the output shaft.
<ul style="list-style-type: none"> Every 3 months 	<ul style="list-style-type: none"> Visual check for external damage and leakage at the seals.
<ul style="list-style-type: none"> Annually 	<ul style="list-style-type: none"> Check the tightening torque of the clamping screw for the clamping ring. For the applicable tightening torque, refer to the table "Tightening torques for clamping screws" or to the clamping ring. Check the tightening torques of the screw connections between the gear unit and the machine and between the output elements and the output shaft.

6.2.1 Wearing parts

Gearing

If you observe the SEW-EURODRIVE design criteria and the inspection and maintenance intervals, then the gearing components of the gear units will be wear-free after the run-in period. The worm gearing is an exception for design reasons. Depending on the operating conditions, material on the tooth flanks of the worm gear is removed to different extents. The main influencing factors are:

- Speed
- Load
- Operating temperature
- Lubricant (type, viscosity, additives, pollution)
- Switching frequency

For information on the worm gearing service life under certain operating conditions, contact SEW-EURODRIVE.

Rolling bearings

Rolling bearings in the gear unit, adapter, and input shaft assembly have a limited service life, even under ideal operating conditions. This nominal bearing service life is a solely statistical value. The actual service life of an individual bearing may deviate greatly from this value. The main influencing factors are:

- Speed
- Equivalent bearing load
- Operating temperature
- Lubricant (type, viscosity, additives, pollution)
- Lubricant supply of the bearing
- Misalignment under operating load

For information on the nominal bearing service life under certain operating conditions, contact SEW-EURODRIVE.

Lubricant

Lubricants are subject to aging. Their service life is limited depending on the load conditions.

The service life depends significantly on the oil operating temperature. The dependency of lubricant change intervals and operating temperature is depicted in the figure in chapter "Lubricant change intervals".

If you have questions about changing lubricant, contact SEW-EURODRIVE.

Oil seals

Oil seals are contact seals that seal unit housings at emerging elements, such as shafts, from the environment. Oil seals are wear parts with a service life that is influenced by the following factors, among others:

- Shaft speed and circumferential speed at the sealing lip
- Ambient conditions (temperature, dust, humidity, pressure, chemicals, radiation)
- Lubricant (type, viscosity, additives, pollution)
- Surface quality of the sealing
- Lubricant supply of the sealing
- Oil seal material

6.2.2 Measuring the oil temperature

The oil temperature must be measured to determine the lubricant change intervals stipulated in chapter "Inspection and Maintenance". To do so, measure the temperature at the bottom of the gear unit. Add 10 K to the measured value. Use this temperature value to determine the lubricant change interval.

6.3 Lubricant change intervals

Use the following figure to determine the number of operating hours between 2 oil changes based on the sustained oil bath temperature at normal ambient conditions. In case of special designs under severe/aggressive ambient conditions, change the lubricant more frequently.

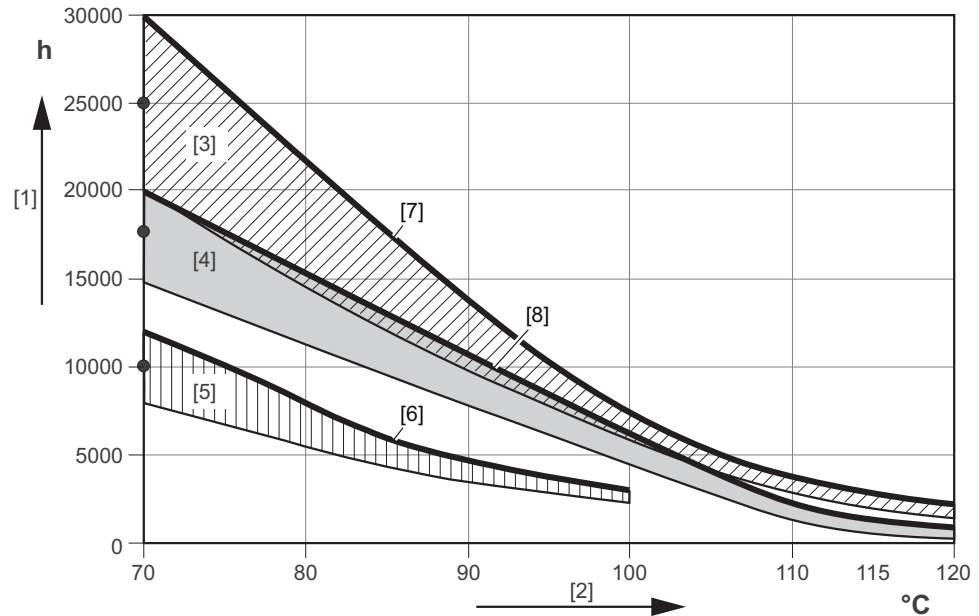

36028797037693579

- [1] Operating hours
- [2] Continuous oil bath temperature
- [3] CLP PG/CLP PG NSF H1
- [4] CLP HC/CLP HC NSF H1
- [5] CLP (CC)/E
- [6] GearOil Base by SEW-EURODRIVE
- [7] GearOil Poly (H1) / GearFluid Poly (H1) by SEW-EURODRIVE
- [8] GearOil Synth (H1) by SEW-EURODRIVE
- Average value for each oil type at 70 °C



6.4 Lubricants

The BS.F.. helical-bevel gear units and PS.F.. planetary gear units from SEW-EURODRIVE are supplied exclusively with synthetic lubricants.

For drives for the food industry, contact SEW-EURODRIVE.

6.4.1 Bearing greases

The table shows the lubricants recommended by SEW-EURODRIVE:

Area of application	Ambient temperature	Manufacturer	Type
Standard	-40 °C to +80 °C	SEW-EURODRIVE	Grease HL 2 E1 ¹⁾
		Fuchs	Renolit CX-TOM 15 ¹⁾
		Klüber	Petamo GHY 133 N
 2)	-40 °C to +40 °C	SEW-EURODRIVE	Grease HL 2 H1 E1
		Bremer & Leguil	Cassida Grease GTS 2
 3)	-20 °C to +40 °C	Fuchs	Plantogel 2S

1) Bearing grease based on semi-synthetic base oil.

2) Lubricant for the food processing industry.

3) Easily biodegradable lubricant for environmentally sensitive areas.

6.4.2 Lubricant table

NOTICE

Damage to the gear unit due to improper lubricants.

Possible damage to property.

- Do not mix synthetic lubricants.
- Do not mix synthetic lubricants and mineral lubricants.

The lubricant recommendation provided in the lubricant table in no way represents a guarantee as to the quality of the lubricant delivered by each respective supplier. Each lubricant manufacturer is responsible for the quality of their product.

Oils of the same viscosity class from different manufacturers do not have the same characteristics. In particular, the minimum and maximum permitted oil bath temperatures are manufacturer-specific. These temperatures are specified in the lubricant tables.

The oil viscosity and type (mineral/synthetic) to be used are determined by SEW-EURODRIVE specifically for each order. This information is noted in the order confirmation and on the gear unit's nameplate. If you use other lubricants for the gear units and/or use the lubricants at temperatures outside the recommended temperature range, SEW-EURODRIVE does not assume liability.

The values specified in the lubricant tables apply as of the time of printing of this document. The data of the lubricants are subject to dynamic change on the part of the lubricant manufacturers. For the latest information about the lubricants, visit: www.sew-eurodrive.de/lubricants.

To avoid gear unit damage, use only one lubricant type.

Information on the table structure

The diagram shows a table structure for selecting lubricants. Callout [1] points to a gear unit icon labeled 'R.'. Callout [2] points to a thermometer showing a temperature range from -50 to +100 °C. Callout [3] points to the ISO, SAE NLGI column. Callout [4] points to a fork icon representing special approvals. Callout [5] points to the lubricant type column.

[1]	[2]	[3]	[4]	[5]
R.	°C -50 0 +50 +100	ISO, SAE NLGI		
	-15	+40	CLP HC - NSF H1 - PSS	VG 460
	-25	+30		VG 220

18014416412986635

- [1] Gear unit type
- [2] Ambient temperature range
- [3] Viscosity class
- [4] Note on special approvals
- [5] Lubricant type

The specified ambient temperatures are guide values for selecting a suitable lubricant. The exact upper and lower temperature limits for project planning are specified in the table with the respective trade name. Bear in mind during project planning that the viscosity increases at low temperatures and that this might influence the starting behavior.

Information on the various lubricants

The diagram shows a table structure for lubricant specifications. Callout [1] points to the lowest oil sump temperature. Callout [2] points to the trade name. Callout [3] points to the manufacturer. Callout [4] points to the highest oil sump temperature. Callout [5] points to the manufacturer's approval code.

[3]	
[1]	-15
[4]	+80
[2]	XYZ108
[5]	SEW070030014

- [1] Lowest oil sump temperature in °C, going below this value during operation is not permitted.
- [2] Trade name
- [3] Manufacturer
- [4] Highest oil sump temperature in °C. The service life will be considerably reduced when this temperature is exceeded. Observe the lubricant change intervals according to chapter "Lubricant change intervals" (→ 58).
- [5] Approvals regarding compatibility of the lubricant with approved oil seals

31544835/EN – 09/2023

Lubricant compatibility with oil seals

Approval	Explanation
SEW07004__13:	A lubricant especially recommended with regard to compatibility with the approved oil seals. The lubricant exceeds the state-of-the-art requirements regarding elastomer compatibility.

Approved application temperature range of the oil seals

In the low temperature range, oil seals can withstand shaft deflections (e. g. through overhung load) only to a limited extent. Especially avoid or limit pulsating or changing radial displacements of the shaft. Contact SEW-EURODRIVE, if required.

Oil seal Material class	Permitted Oil sump temperature
NBR	-40 °C to +80 °C
FKM	-25 °C to +115 °C
FKM-PSS	-25 °C to +115 °C

Restrictions of use of oil seals with the specific lubricant are described in the following table:

Material class		Manufacturer		Material		
S	1	NBR	1	Freudenberg	72 NBR 902	
			2	Trelleborg	4NV11	
	2	FKM	1	Freudenberg	1	75 FKM 585
						2
			2	Trelleborg	1	VCBVR
				SKF	1	FKM 00934







Examples:

S11: Only the elastomer 72NBR902 from Freudenberg meets the requirements of the approval in conjunction with the specific lubricant.

S2: Only the elastomer FKM meets the requirements of the approval in conjunction with the specific lubricant.

Key

The following table shows the symbols and abbreviations used in the lubricant table and their meaning.

Abbreviation/symbol	Meaning
	Synthetic lubricant (marked gray)
	Mineral lubricant
CLP	Mineral oil
CLP PG	Polyglycol (PG)
rPCF	Reduced Product Carbon Footprint
CLP HC	Synthetic hydrocarbons to polyalphaolefins (PAO)
E	Ester-based oil
	Lubricant for the food processing industry and feed industry. Oils are NSF-H1 registered and compliant in accordance with FDA 21 CFR § 178.3570
	Lubricants with particularly reduced CO ₂ footprint (cradle-to-gate) with sustainable raw materials.
	Lubricants with slight bio-degradability for environmentally sensitive areas (> 60% according to OECD 301 or according to appendix A of EPA 2013 VGP)
	Lubricant suitable for explosion-protected gear units and gearmotors
1)	Helical-worm gear units with CLP-PG: Contact SEW-EURODRIVE.
2)	Low-viscosity grease
3)	With appropriate measures, the gear units can be operated at ambient temperatures as low as -40 °C. Contact SEW-EURODRIVE.
4)	Oils for the food processing industry cannot be combined with the gear unit option "Extended storage" (a VCI anti-corrosion agent is added).
Oil seal	Oil seal
Premium Sine Seal	Oil seal of the Premium Sine Seal type. The addendum "PSS" for the lubricant type indicates compatibility with the sealing system.

Lubricant table for BS.F, PS.F and PS.C gear units

The lubricant table is valid on the day this document is published. See www.sew-eurodrive.de/lubricants for the latest tables.

6.4.3 Lubricant fill quantities

The following tables show guide values for lubricant fill quantities in relation to mounting positions M1 to M6.

The exact values vary depending on the number of gear stages and the gear ratio. Always check the oil level plug during filling for the exact oil quantity.

Unless a special arrangement is made, SEW-EURODRIVE supplies the drives with a lubricant fill adapted for the specific mounting position. The mounting position (see chapter "Designation of the mounting positions") must therefore be specified in the drive order.

When the mounting position is changed, the lubricant fill quantity must be adapted accordingly (see the following chapters). Do not change the mounting position without prior consultation with SEW-EURODRIVE, otherwise the rights to claim under limited warranty become void.

BS.F.. Helical-bevel gear units

The following tables show guide values for lubricant fill quantities in relation to mounting positions M1 to M6.

Fill quantities for BS.F.. helical-bevel gear units

BS.F.. Helical-bevel gear units	Fill quantity in liters					
	M1	M2	M3	M4	M5	M6
BS.F202	0.15	0.25	0.25	0.30	0.25	0.25
BS.F302	0.25	0.50	0.50	0.55	0.35	0.35
BS.F402	0.45	0.80	0.80	1.05	0.65	0.65
BS.F502	1.00	1.80	1.80	2.50	1.50	1.50
BS.F602	1.60	2.50	2.80	4.10	2.00	2.60
BS.F802	3.30	5.30	5.70	7.90	4.50	4.50

Fill quantity tolerance for BSF..

Fill quantity in liters	Tolerance
Up to 1 l	0.01 l
> 1 l	1% of the fill quantity

PS.F.. Planetary gear units

The following tables show guide values for lubricant fill quantities in relation to the mounting position M1 – M6.

Fill quantities for PS(K)F.. planetary gear units

PS(K)F.. planet- ary gear unit	Adapter mounting Fill quantity in liters			Direct motor mounting Fill quantity in liters		
	M1 (M3, M5, M6)	M2	M4	M1 (M3, M5, M6)	M2	M4
PS(K)F121	0.023	0.025	0.023	0.023	0.037	0.023
PS(K)F122	0.035	0.056	0.054	0.035	0.068	0.054
PS(K)F221	0.035	0.052	0.035	0.035	0.063	0.035
PS(K)F222	0.045	0.075	0.085	0.045	0.085	0.085
PS(K)F321	0.070	0.100	0.070	0.07	0.12	0.07
PS(K)F322	0.095	0.170	0.190	0.095	0.185	0.19
PS(K)F521	0.140	0.215	0.150	0.14	0.245 (0.270) ¹⁾	0.15
PS(K)F522	0.200	0.360	0.395	0.2	0.38	0.395
PS(K)F621	0.300	0.465	0.320	0.3	0.500 (0.550) ¹⁾	0.32
PS(K)F622	0.410	0.680	0.780	0.41	0.71	0.78
PS(K)F721	0.600	0.930	0.650	0.6	1.060	0.65
PS(K)F722	0.750	1.230	1.645	0.75	1.280	1.645
PS(K)F821	1.000	1.750	1.350	–	–	–
PS(K)F822	1.550	2.550	3.350	1.550	2.640	3.350
PS(K)F921	1.400	2.450	1.900	–	–	–
PS(K)F922	2.050	3.500	4.350	2.050	3.650	4.350

1) Fill quantity for direct mounting of CFM90 servomotors

Fill quantities for PSBF.. planetary gear units

Planetary gear units PSBF..	Adapter mounting Fill quantity in liters			Direct motor mounting Fill quantity in liters		
	M1 (M3, M5, M6)	M2	M4	M1 (M3, M5, M6)	M2	M4
PSBF221	0.025	0.040	0.025	0.025	0.051	0.025
PSBF222	0.035	0.061	0.060	0.035	0.074	0.06
PSBF321	0.045	0.068	0.050	0.045	0.085	0.05
PSBF322	0.070	0.135	0.130	0.07	0.145	0.13
PSBF521	0.093	0.143	0.103	0.093	0.168 (0.193) ¹⁾	0.103
PSBF522	0.143	0.288	0.273	0.143	0.308	0.273
PSBF621	0.198	0.318	0.188	0.198	0.358 (0.408) ¹⁾	0.188
PSBF622	0.298	0.538	0.498	0.298	0.568	0.498
PSBF721	0.474	0.684	0.314	0.404	0.544	0.314
PSBF722	0.564	0.884	1.004	0.544	0.834	1.004
PSBF821	0.495	0.995	0.695	–	–	–
PSBF822	0.995	1.795	1.995	0.995	1.895	1.995

1) Fill quantity for direct mounting of CFM90 servomotors

Fill quantity tolerance for PS.F

Fill quantity in liters	Tolerance
Up to 1 l	0.01l
> 1 l	1% of the fill quantity

PSC.. planetary gear units

Oil fill quantities for motor mounting in liter

PS.C	CMP40	CMP50	DS56	CMP63	CM71	CMP71	CMP80	CM90	CMP 100	CM112
221	0.060	0.060	0.060	0.060						
222	0.115	0.115	0.115	0.110						
321		0.145	0.145	0.145	0.130	0.130				
322		0.260	0.260	0.260	0.250	0.250				
521		0.240	0.240	0.260	0.260	0.260	0.260	0.270		
522		0.505	0.505	0.505	0.505	0.505	0.505	0.505		
621				0.515	0.500	0.500	0.500	0.585	0.500	0.540
622				0.925	0.910	0.910	0.910	0.995	0.910	0.950

Oil fill quantities for adapter mounting in liter

PS.C	ECH02	ECH03	ECH05	ECH06	EPH01	EPH02	EPH03	EPH04	EPH05	EPH06	EPH07	EPH08
221	0.040				0.040	0.040	0.040	0.050				
222	0.100				0.100	0.100	0.100	0.105				
321		0.090						0.115	0.115			
322		0.210						0.240	0.240			
521			0.195					0.215	0.215	0.230	0.230	
522			0.465					0.490	0.490	0.500	0.500	
621				0.450				0.465	0.495	0.495	0.460	
622				0.860				0.875	0.905	0.905	0.870	

PS.C	Fill quantity tolerance in liters
221/222	± 0.001
321/322	± 0.002
521/522	± 0.005
621/622	± 0.005

Total with single-stage gear units

Grease fill quantities for motor mounting in liter

PS.C	CMP40	CMP50	DS56	CMP63	CM71	CMP71	CMP80	CM90	CMP 100	CM112
221	0.060	0.060	0.060	0.055						
321		0.135	0.135	0.135	0.135	0.135				
521		0.265	0.265	0.265	0.260	0.260	0.260	0.260		
621				0.570	0.555	0.555	0.555	0.570	0.555	0.570

Grease fill quantities for adapter mounting in liter

PS.C	ECH02	ECH03	ECH05	ECH06	EPH01	EPH02	EPH03	EPH04	EPH05	EPH06	EPH07	EPH08
221	0.050				0.050	0.050	0.050	0.055				
321		0.095						0.130	0.125			
521			0.240					0.255	0.255	0.255	0.255	
621				0.570				0.580	0.565	0.565	0.555	

INFORMATION



With two-stage gear units with grease fill, the two gear stages must be filled separately with oil!

31544835/EN – 09/2023

Input stage with two-stage gear units

Grease fill quantities for motor mounting in liter

PS.C	CMP40	CMP50	DS56	CMP63	CM71	CMP71	CMP80	CM90	CMP 100	CM112
222	0.060	0.060	0.060	0.055						
322		0.135	0.135	0.135	0.135	0.135				
522		0.265	0.265	0.265	0.260	0.260	0.260	0.260		
622				0.570	0.555	0.555	0.555	0.575	0.555	0.560

Grease fill quantities for adapter mounting in liter

PS.C	ECH02	ECH03	ECH05	ECH06	EPH01	EPH02	EPH03	EPH04	EPH05	EPH06	EPH07	EPH08
222	0.050				0.050	0.050	0.050	0.060				
322		0.095						0.130	0.125			
522			0.235					0.235	0.235	0.235	0.235	
622				0.540					0.550	0.560	0.560	0.555

Output stage with two-stage gear units

Grease fill quantity in liters

PS.C	All mountings
222	0.050
322	0.110
522	0.215
622	0.420

PS.C	Fill quantity tolerance in liters
221/222	± 0.001
321/322	± 0.002
521/522	± 0.005
621/622	± 0.005

6.5 Extended storage

INFORMATION



For storage periods longer than 9 months, SEW-EURODRIVE recommends the "extended storage" gear unit type. Gear units in this design are designated with a corresponding label.

INFORMATION



The gear units must remain tightly sealed until taken into operation to prevent the VCI anti-corrosion agent from evaporating.

For gear units of the "extended storage" design, the following measures are taken:

- The lubricant is mixed with a VCI anti-corrosion agent (volatile corrosion inhibitors).
Bear in mind that this VCI anti-corrosion agent is only effective in a temperature range from -25 °C to +50 °C.
- The flange contact surfaces and shaft ends are also treated with an anti-corrosion agent.

6.5.1 Storage conditions for long-term storage

Observe the storage conditions specified in the following table for extended storage.

Climate zone	Packaging ¹⁾	Storage ²⁾	Storage duration
Temperate (Europe, USA, Canada, China and Russia, excluding tropical zones)	<ul style="list-style-type: none"> • Packed in containers • With desiccant and moisture indicator sealed in the plastic wrap 	<ul style="list-style-type: none"> • Roofed • Protected against rain and snow • And shocks 	Up to 4 years with regular inspection of the packaging and humidity indicator (rel. humidity < 50%)
	Open	<ul style="list-style-type: none"> • Under roof and enclosed at constant temperature and atmospheric humidity (5 °C < ϑ < 50 °C, relative humidity < 50%) • No sudden temperature variations • Controlled ventilation with filter (free from dust and dirt) • No aggressive vapors • No shocks 	2 years or more with regular inspections <ul style="list-style-type: none"> • Check for cleanness and mechanical damage during the inspection • Check corrosion protection

31544835/EN – 09/2023

Climate zone	Packaging ¹⁾	Storage ²⁾	Storage duration
Tropical (Asia, Africa, Central and South America, Australia, New Zealand exclud- ing temperate zones)	<ul style="list-style-type: none"> • Packed in containers • With desiccant and moisture indicator sealed in the plastic wrap • Protected against insect damage and mildew by chemical treatment 	<ul style="list-style-type: none"> • Roofed • Protected against rain and snow • And shocks 	Up to 3 years with regular inspection of the packaging and humidity indicator (rel. humidity < 50%)
	Open	<ul style="list-style-type: none"> • Under roof and enclosed at constant temperature and atmospheric humidity (5 °C < ϑ < 50 °C, relative humidity < 50%) • No sudden temperature variations • Controlled ventilation with filter (free from dust and dirt) • No aggressive vapors • No shocks • Protected against insect damage 	2 years or more with regular inspections <ul style="list-style-type: none"> • Check for cleanness and mechanical damage during the inspection • Check corrosion protection

1) Packaging must be carried out by an experienced company using packaging material specifically suited for the application.

2) SEW-EURODRIVE recommends storing the gear units according to the mounting position.

7 Mounting positions

7.1 General information on the mounting positions – BS.F, PS.F, PS.C gear units

The following illustration shows the SEW-EURODRIVE mounting positions M1 – M6:

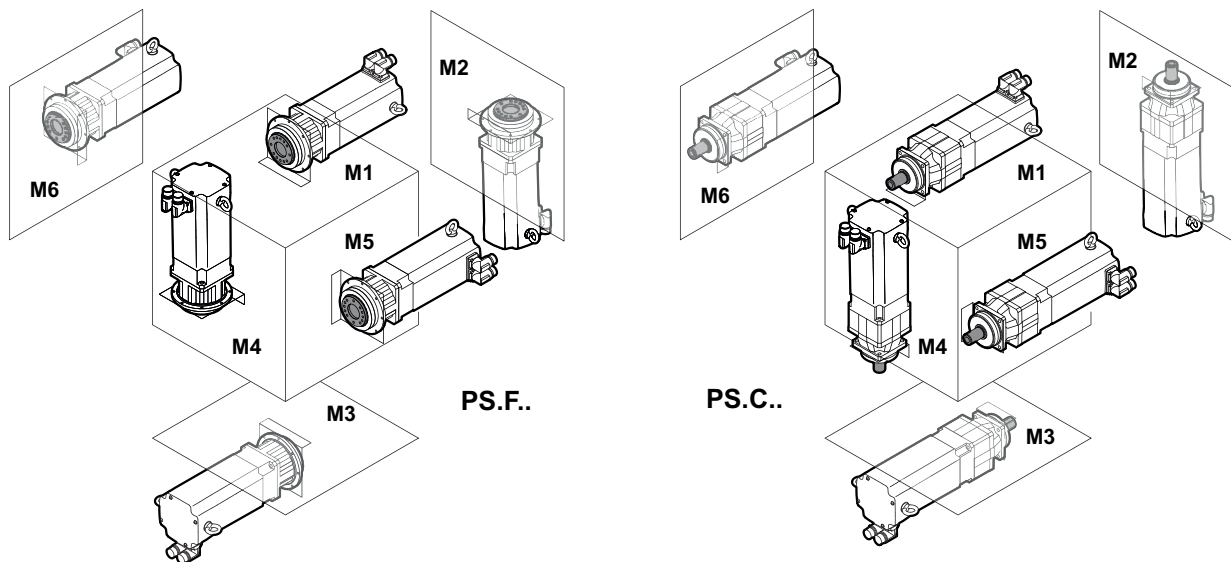
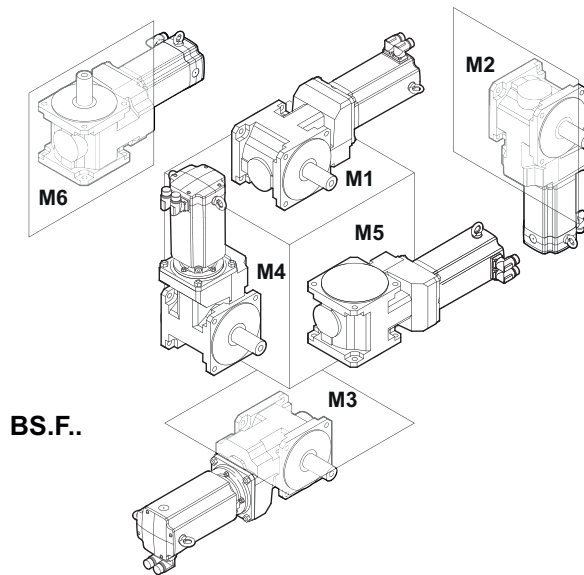

35036526347

7.2 Mounting position sheets

7.2.1 Dimension sheet information

Position of the valves and screws	The positions of the breather valve specified in the mounting position sheets are binding and comply with the assembly specifications. The motors are only depicted symbolically on the mounting position sheets.
Representation of the shaft	For gear units with solid shaft, the shaft shown is always on the A-side. For shaft-mounted gear units, the customer shaft is shown as a dashed line. The output end (position of the output shaft) is always shown on the A-side.
Mounting position M0	Some gear units can be supplied in mounting position M0. In this case, the gear unit is delivered in a universal mounting position and can be adjusted to various mounting positions by the customer. It may be necessary to contact SEW-EURODRIVE.

Symbols used

The following table shows the symbols used in the mounting position sheets and what they mean:

Symbol	Meaning
	Breather valve

7.2.2 Mounting positions of BS.F helical-bevel gearmotors
BSF202-802

56 037 02 03

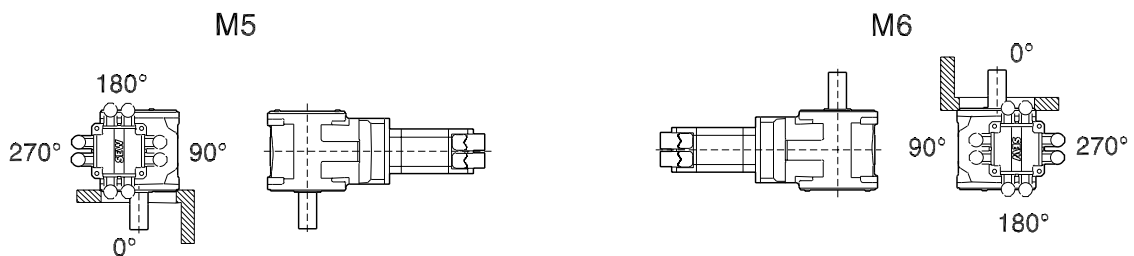
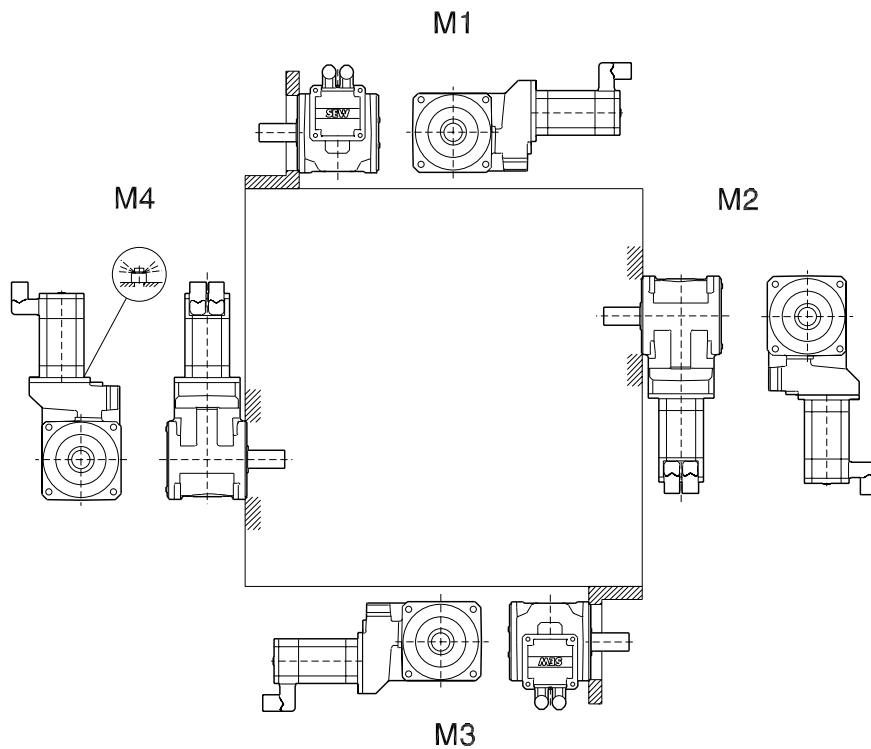
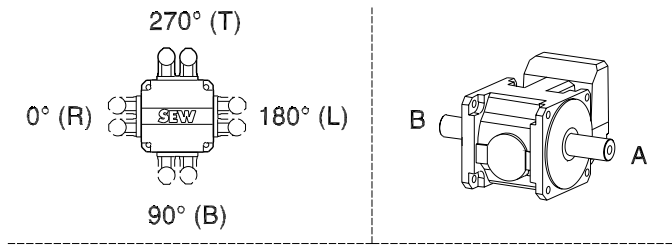

31544835/EN – 09/2023

7 Mounting positions

Mounting position sheets

BSBF202-802

56 038 02 03

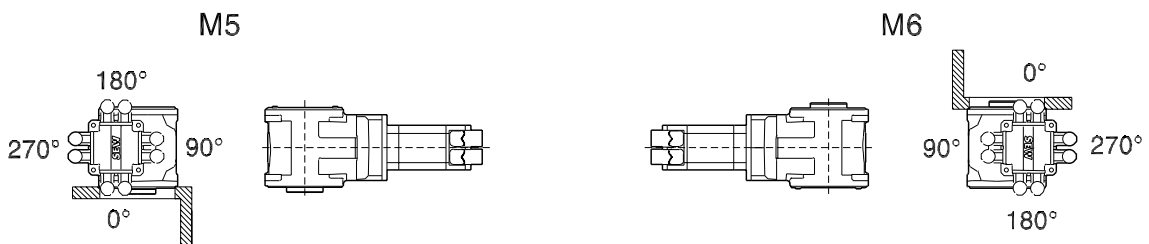
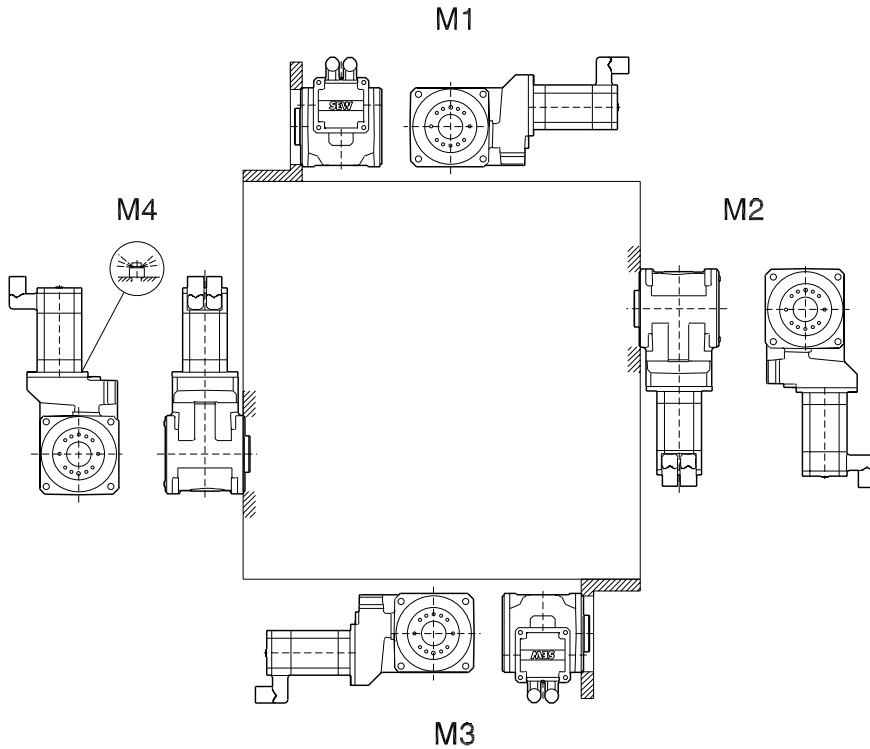
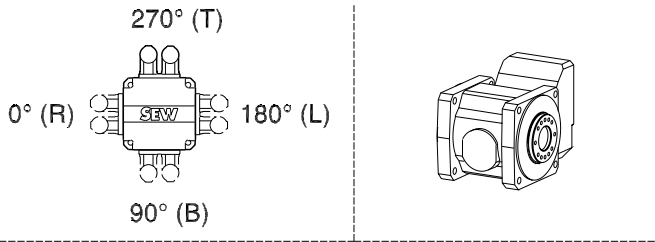

31544835/EN – 09/2023

BSHF202-802

56 056 02 03

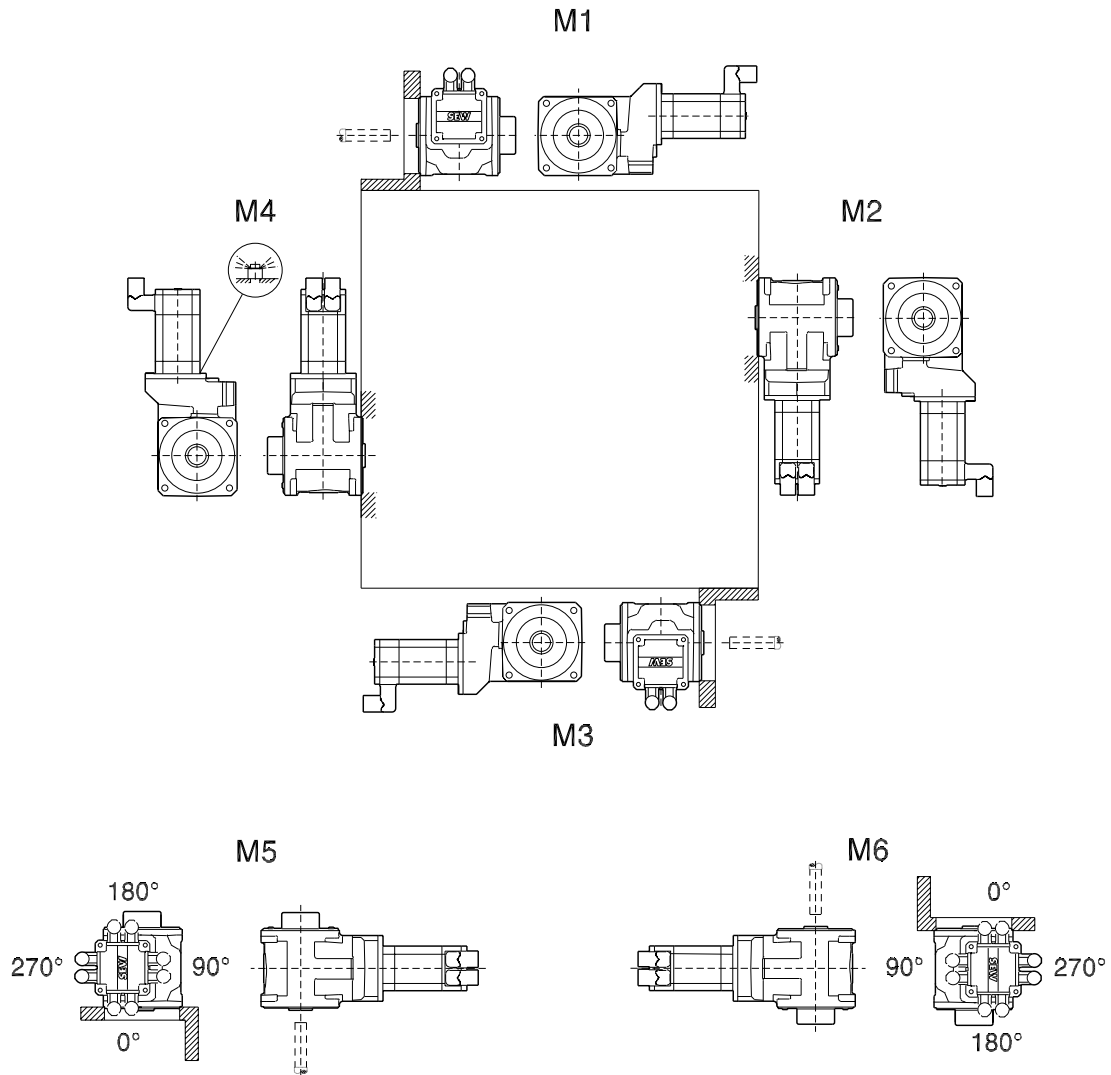
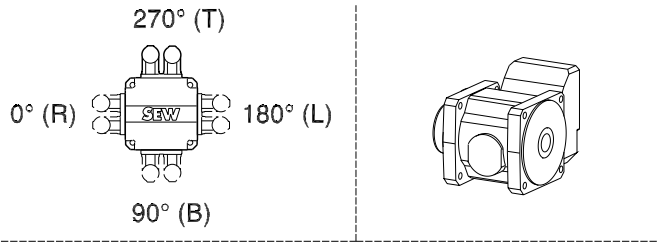

BSHF202-802 /I

56 039 02 03

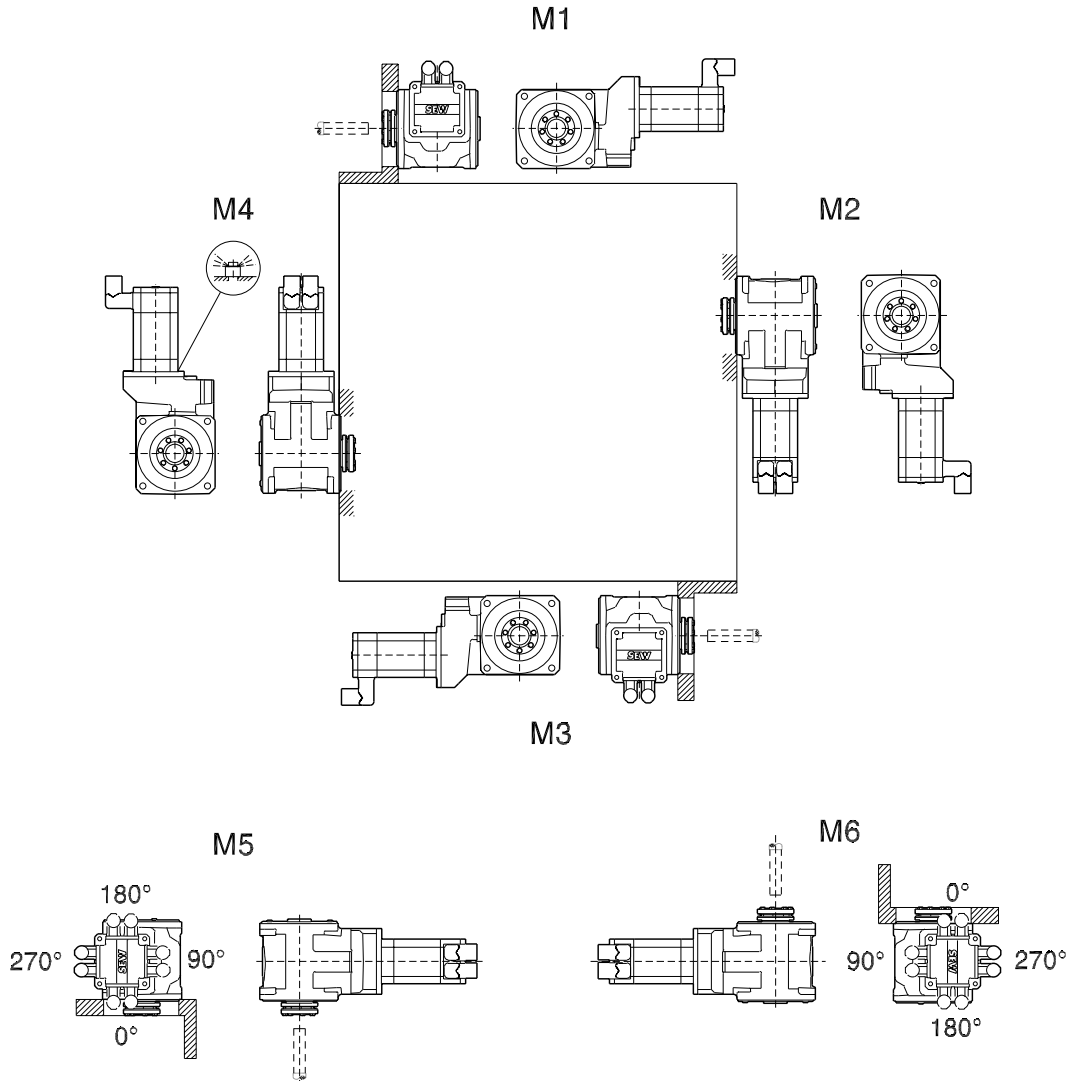
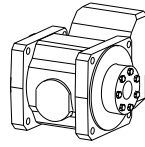
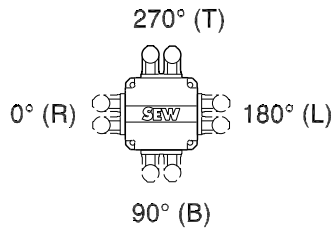

BSHF202-802 /T

56 043 02 03

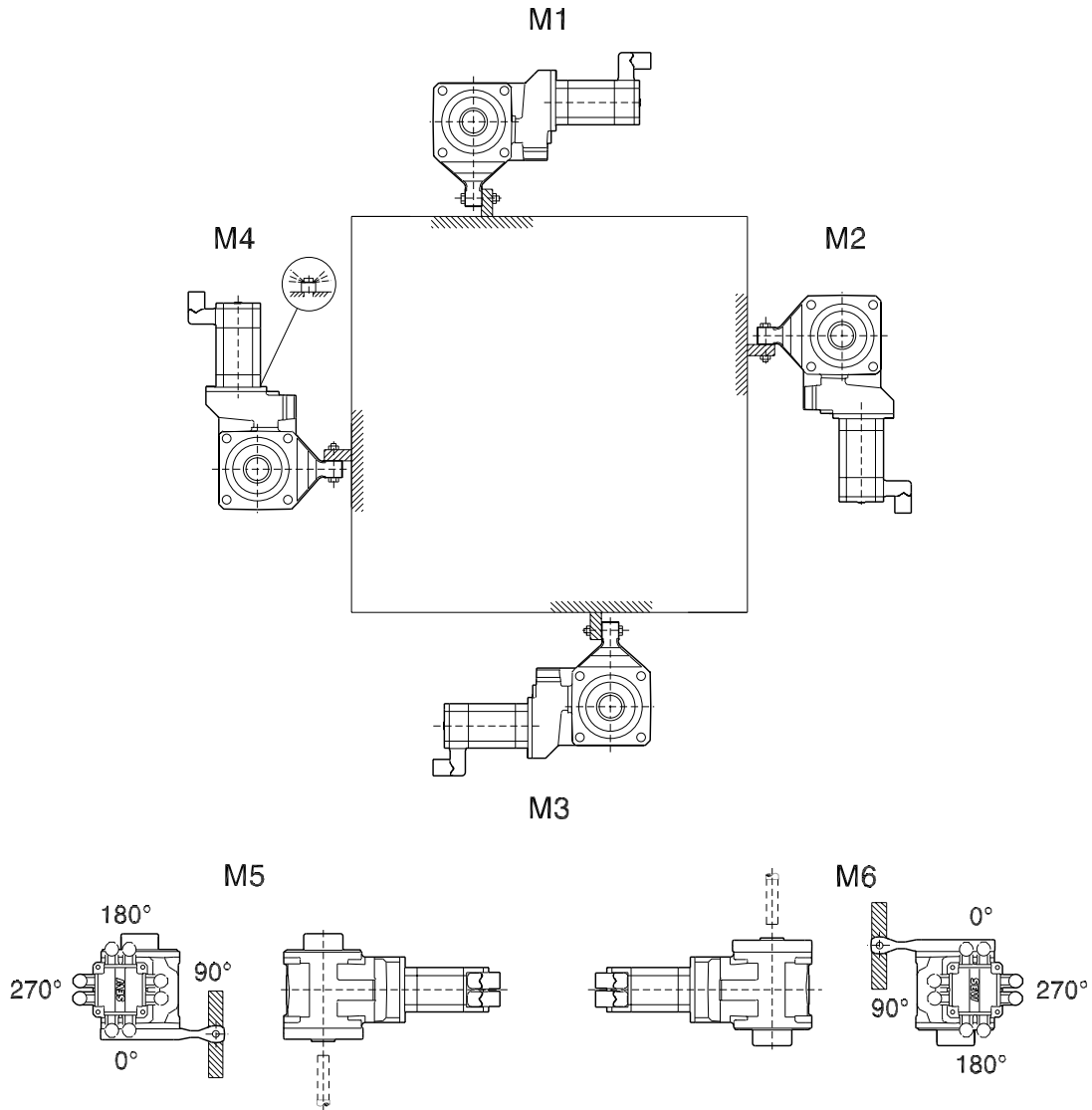
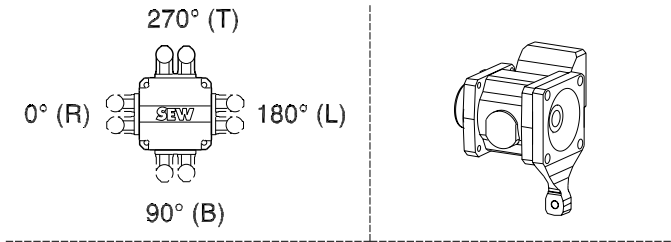

31544835/EN – 09/2023

BSF202B-802B

56 040 02 03

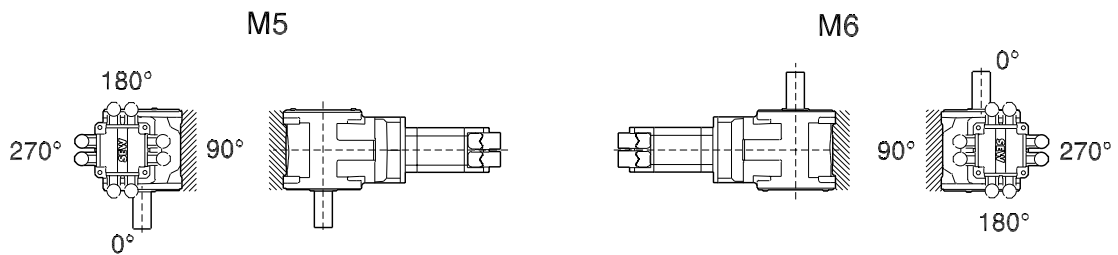
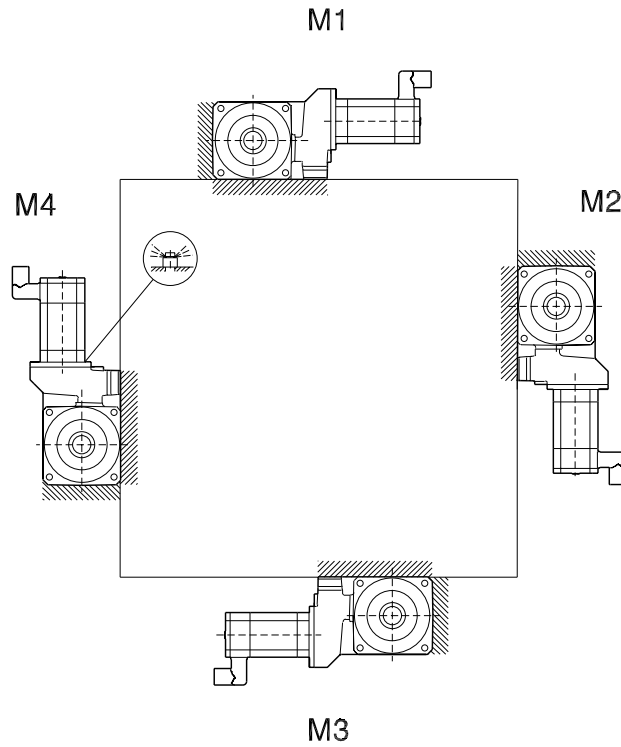
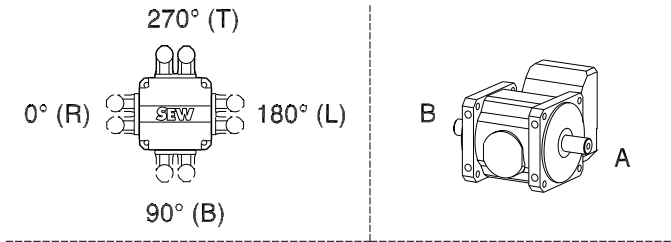

BSBF202B-802B

56 041 02 03

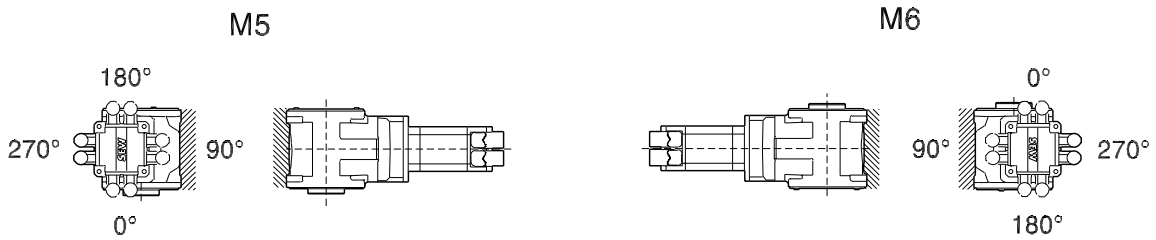
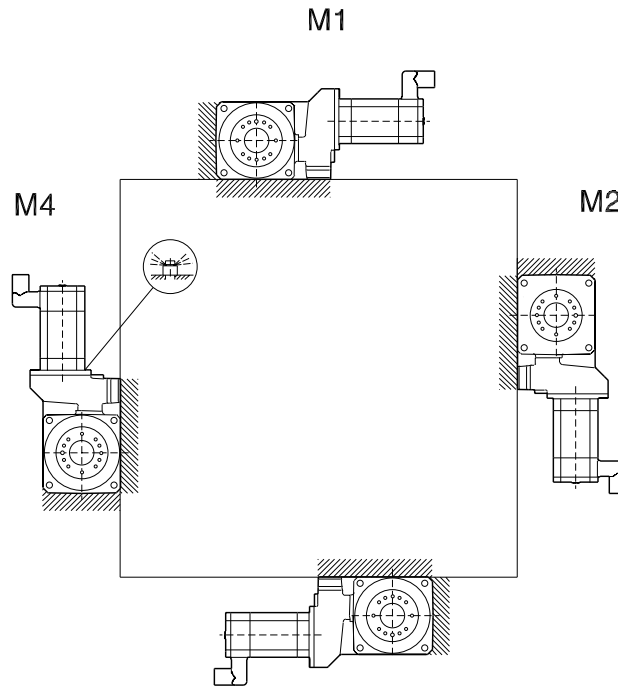
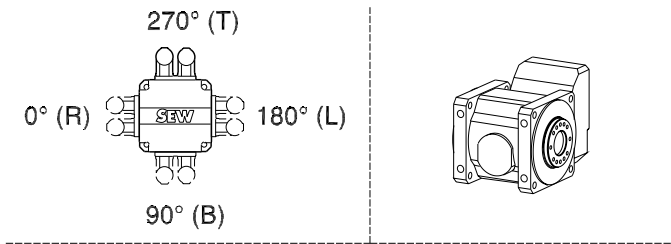

31544835/EN – 09/2023

BSHF202B-802B

56 057 02 03

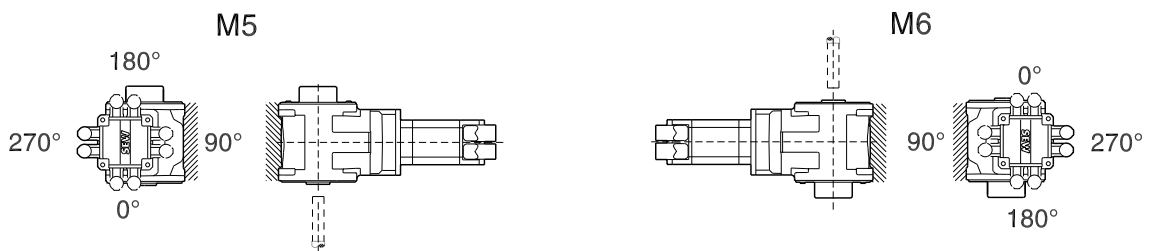
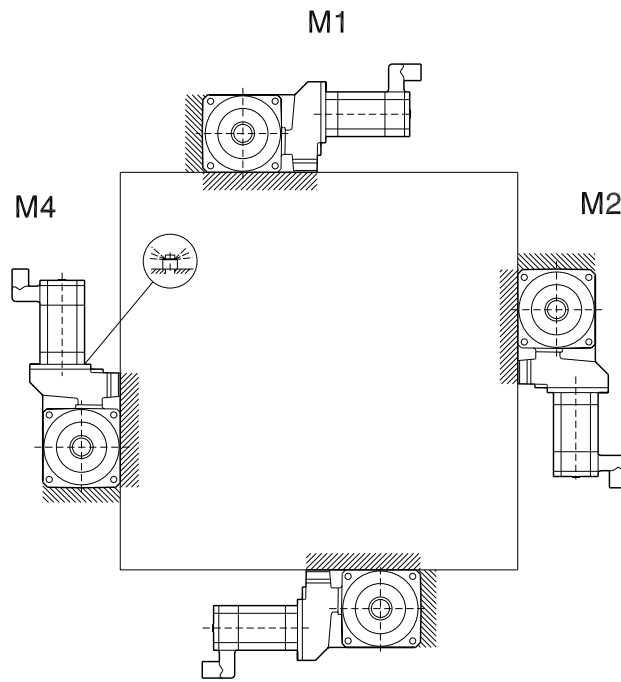
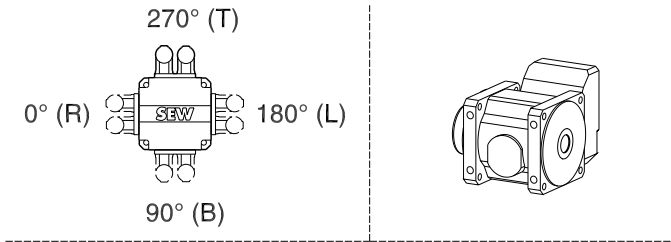

BSHF202B-802B //

56 042 02 03

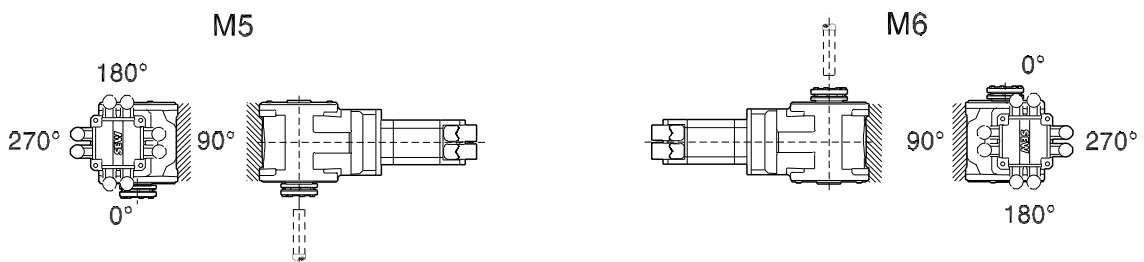
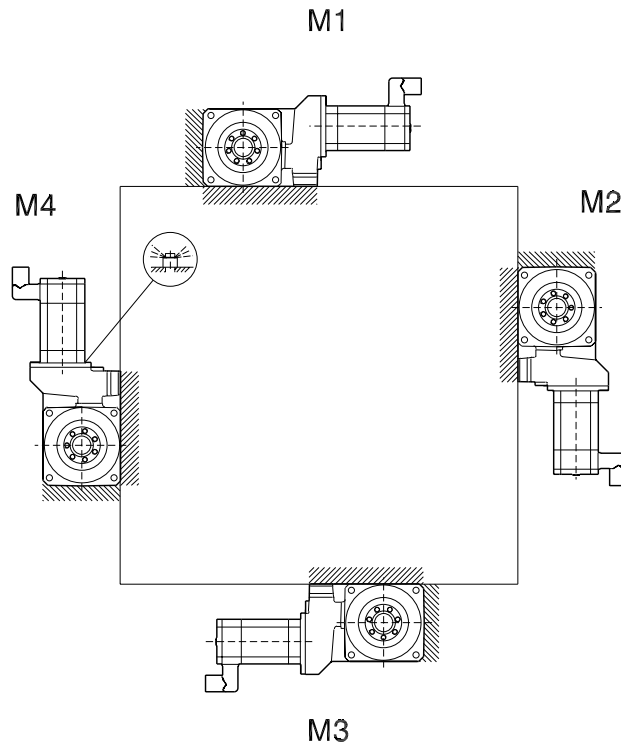
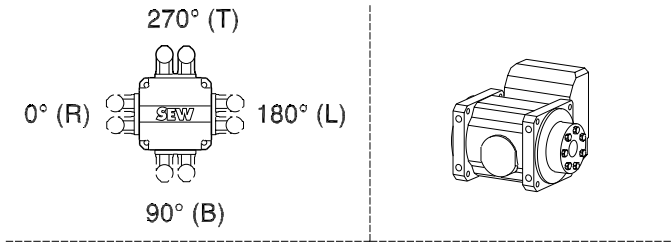

31544835/EN – 09/2023

7.2.3 Mounting positions of PS.F, PS.C planetary gearmotors

PS.F121-922/PS.C221-622

58 001 02 03

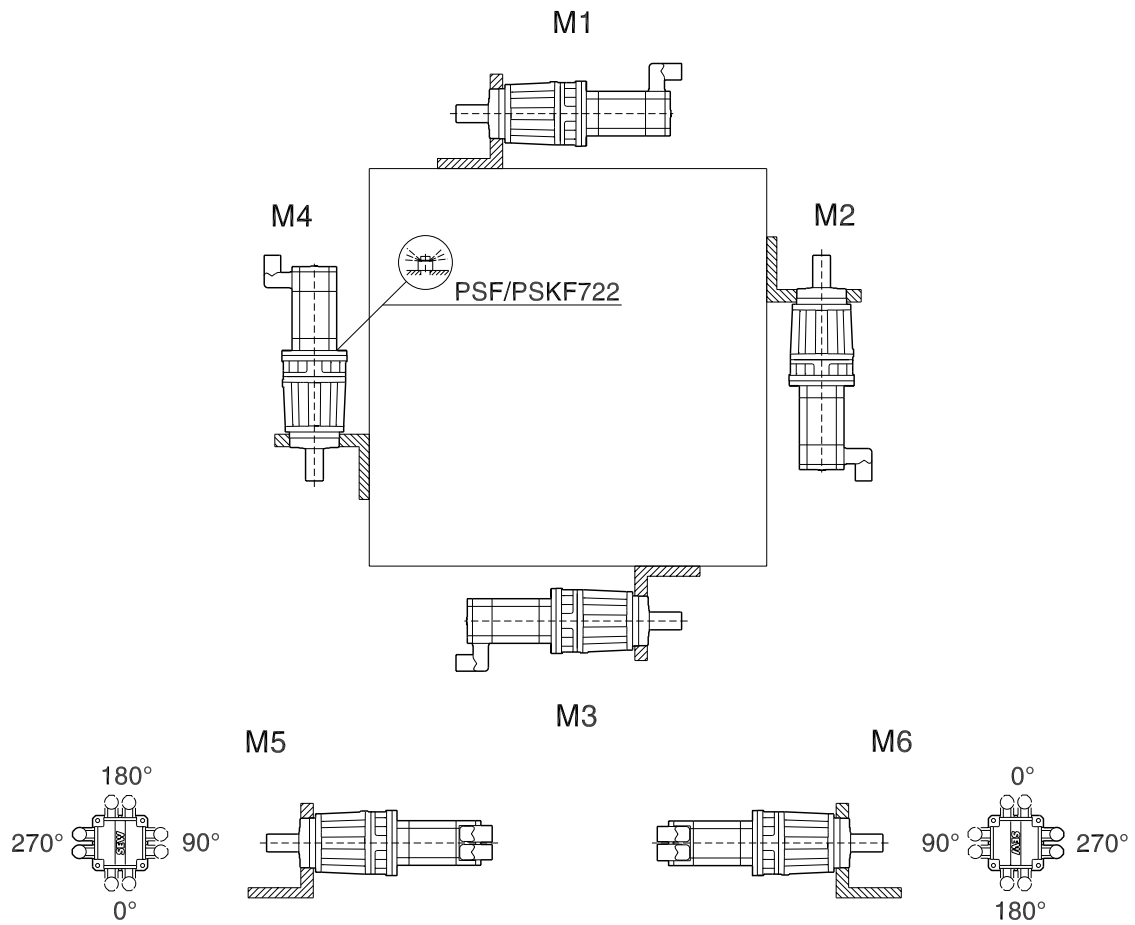
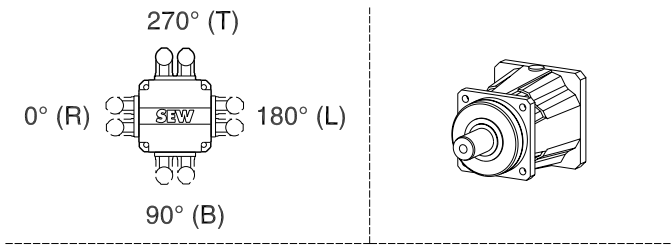

PSBF121-922

58 002 01 03

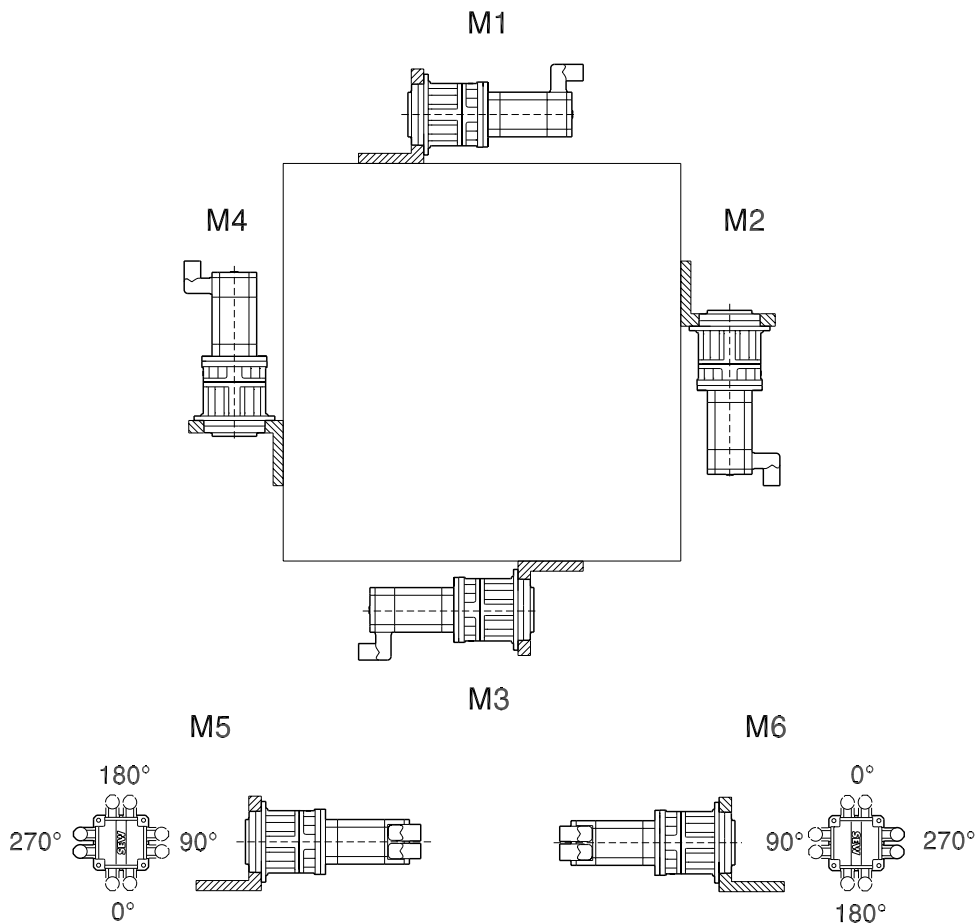
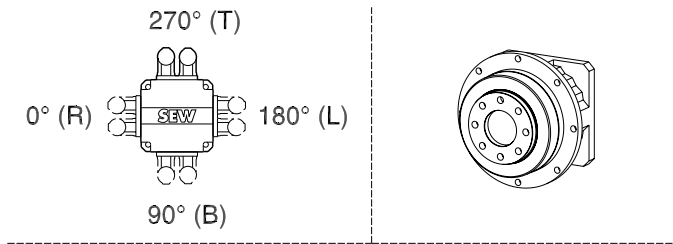

31544835/EN – 09/2023

8 Malfunctions

8.1 Failures on the servo gear unit

Fault	Possible cause	Measure
Unusual, regular running noise.	Meshing/grinding noise: Bearing damage	Contact SEW-EURODRIVE.
	Knocking noise: Irregularity in the gearing	Contact SEW-EURODRIVE.
	Incorrect controller setting	Check the controller settings.
Unusual, irregular running noises	<ul style="list-style-type: none"> Foreign objects in the oil 	<ul style="list-style-type: none"> Check the oil consistency Stop the drive, contact SEW-EURODRIVE
Oil leakage ¹⁾ <ul style="list-style-type: none"> From the motor flange From the motor oil seal From the gear unit flange From the output end oil seal. 	<ul style="list-style-type: none"> Seal defective. Only for BSF.. gear units in mounting position M4: Gear unit not ventilated 	<ul style="list-style-type: none"> Contact SEW-EURODRIVE. Vent gear unit
Only for BSF.. Mounting position M4: Oil leaking from breather valve.	Too much oil	Contact SEW-EURODRIVE.
	Drive operated in incorrect mounting position	Mount the gear unit in the correct mounting position
	Frequent cold starts (oil foaming) and/or high oil level	Install oil expansion tank.
Output shaft does not turn although the motor is running or the input shaft is rotated	Shaft-hub connection in the gear unit interrupted	Send in the gear unit/gearmotor for repair
Housing temperature is > 95 °C	Restricted air supply	Ensure unrestricted air supply and/or contact SEW-EURODRIVE.
	Speed/torque is too high	Check dimensioning and/or contact SEW-EURODRIVE.

1) Short-term oil / grease leakage at the oil seal is possible in the run-in phase (48 hours running time).

8.2 Service

Please have the following information available if you require customer service assistance:

- Nameplate data (complete)
- Type and extent of the failure
- Time the failure occurred and any accompanying circumstances
- Assumed cause

8.3 Waste disposal

Dispose of the product and all parts separately in accordance with their material structure and the national regulations. Put the product through a recycling process or contact a specialist waste disposal company. If possible, divide the product into the following categories:

- Iron, steel or cast iron
- Stainless steel
- Aluminum
- Copper
- Plastics

The following materials are hazardous to health and the environment. These materials must be collected and disposed of separately:

- Oil and grease

Collect used oil and grease separately according to type. Ensure that the used oil is not mixed with solvent. Dispose of used oil and grease correctly.

9 Address list

Argentina

Assembly Sales	Buenos Aires	SEW EURODRIVE ARGENTINA S.A. Ruta Panamericana Km 37.5, Lote 35 (B1619IEA) Centro Industrial Garín Prov. de Buenos Aires	Tel. +54 3327 4572-84 Fax +54 3327 4572-21 http://www.sew-eurodrive.com.ar sewar@sew-eurodrive.com.ar
-------------------	--------------	---	--

Australia

Assembly Sales Service	Melbourne	SEW-EURODRIVE PTY. LTD. 27 Beverage Drive Tullamarine, Victoria 3043	Tel. +61 3 9933-1000 Fax +61 3 9933-1003 http://www.sew-eurodrive.com.au enquires@sew-eurodrive.com.au
	Sydney	SEW-EURODRIVE PTY. LTD. 9, Sleigh Place, Wetherill Park New South Wales, 2164	Tel. +61 2 9725-9900 Fax +61 2 9725-9905 enquires@sew-eurodrive.com.au

Austria

Assembly Sales Service	Vienna	SEW-EURODRIVE Ges.m.b.H. Richard-Strauss-Straße 24 1230 Wien	Tel. +43 1 617 55 00-0 Fax +43 1 617 55 00-30 http://www.sew-eurodrive.at sew@sew-eurodrive.at
------------------------------	--------	--	---

Bangladesh

Sales	Bangladesh	SEW-EURODRIVE INDIA PRIVATE LIMITED 345 DIT Road East Rampura Dhaka-1219, Bangladesh	Tel. +88 01729 097309 salesdhaka@seweurodrivebangladesh.com
-------	------------	---	---

Belarus

Sales	Minsk	Foreign unitary production enterprise SEW- EURODRIVE Novodvorskiy village council 145 223016, Minsk region	Tel. +375 17 319 47 56 / +375 17 378 47 58 Fax +375 17 378 47 54 http://www.sew-eurodrive.by sew@sew-eurodrive.by
-------	-------	---	--

Belgium

Assembly Sales Service	Brussels	SEW-EURODRIVE n.v./s.a. Researchpark Haasrode 1060 Evenementenlaan 7 3001 Leuven	Tel. +32 16 386-311 Fax +32 16 386-336 http://www.sew-eurodrive.be info@sew-eurodrive.be
Service Competence Center	Industrial Gears	SEW-EURODRIVE n.v./s.a. Rue du Parc Industriel, 31 6900 Marche-en-Famenne	Tel. +32 84 219-878 Fax +32 84 219-879 http://www.sew-eurodrive.be info@sew.be

Brazil

Production Sales Service	São Paulo	SEW-EURODRIVE Brasil Ltda. Estrada Municipal José Rubim, 205 – Rodovia Santos Dumont Km 49 Indaiatuba – 13347-510 – SP	Tel. +55 19 3835-8000 sew@sew.com.br
Assembly Sales Service	Rio Claro	SEW-EURODRIVE Brasil Ltda. Rodovia Washington Luiz, Km 172 Condomínio Industrial Conpark Caixa Postal: 327 13501-600 – Rio Claro / SP	Tel. +55 19 3522-3100 Fax +55 19 3524-6653 montadora.rc@sew.com.br
	Joinville	SEW-EURODRIVE Brasil Ltda. Jvl / Ind Rua Dona Francisca, 12.346 – Pirabeiraba 89239-270 – Joinville / SC	Tel. +55 47 3027-6886 Fax +55 47 3027-6888 filial.sc@sew.com.br

Bulgaria

Sales	Sofia	BEVER-DRIVE GmbH Bogdanovetz Str.1 1606 Sofia	Tel. +359 2 9151160 Fax +359 2 9151166 bever@bever.bg
-------	-------	---	---

Cameroon			
Sales	Douala	SEW-EURODRIVE SARLU Ancienne Route Bonabéri P.O. Box B.P 8674 Douala-Cameroun	Tel. +237 233 39 12 35 Fax +237 233 39 02 10 www.sew-eurodrive.ci/ info@sew-eurodrive.cm
Canada			
Assembly Sales Service	Toronto	SEW-EURODRIVE CO. OF CANADA LTD. 210 Walker Drive Bramalea, ON L6T 3W1	Tel. +1 905 791-1553 Fax +1 905 791-2999 http://www.sew-eurodrive.ca l.watson@sew-eurodrive.ca
	Vancouver	SEW-EURODRIVE CO. OF CANADA LTD. Tilbury Industrial Park 7188 Honeyman Street Delta, BC V4G 1G1	Tel. +1 604 946-5535 Fax +1 604 946-2513 b.wake@sew-eurodrive.ca
	Montreal	SEW-EURODRIVE CO. OF CANADA LTD. 2001 Ch. de l'Aviation Dorval Quebec H9P 2X6	Tel. +1 514 367-1124 Fax +1 514 367-3677 n.paradis@sew-eurodrive.ca
Chile			
Assembly Sales Service	Santiago de Chile	SEW-EURODRIVE CHILE LTDA Las Encinas 1295 Parque Industrial Valle Grande LAMP Santiago de Chile P.O. Box Casilla 23 Correo Quilicura - Santiago - Chile	Tel. +56 2 2757 7000 Fax +56 2 2757 7001 http://www.sew-eurodrive.cl ventas@sew-eurodrive.cl
China			
Production Assembly Sales Service	Tianjin	SEW-EURODRIVE (Tianjin) Co., Ltd. No. 78, 13th Avenue, TEDA Tianjin 300457	Tel. +86 22 25322612 Fax +86 22 25323273 http://www.sew-eurodrive.cn info@sew-eurodrive.cn
Assembly Sales Service	Suzhou	SEW-EURODRIVE (Suzhou) Co., Ltd. 333, Suhong Middle Road Suzhou Industrial Park Jiangsu Province, 215021	Tel. +86 512 62581781 Fax +86 512 62581783 suzhou@sew-eurodrive.cn
	Guangzhou	SEW-EURODRIVE (Guangzhou) Co., Ltd. No. 9, JunDa Road East Section of GETDD Guangzhou 510530	Tel. +86 20 82267890 Fax +86 20 82267922 guangzhou@sew-eurodrive.cn
	Shenyang	SEW-EURODRIVE (Shenyang) Co., Ltd. 10A-2, 6th Road Shenyang Economic Technological Development Area Shenyang, 110141	Tel. +86 24 25382538 Fax +86 24 25382580 shenyang@sew-eurodrive.cn
	Taiyuan	SEW-EURODRIVE (Taiyuan) Co., Ltd. No.3, HuaZhang Street, TaiYuan Economic & Technical Development Zone ShanXi, 030032	Tel. +86-351-7117520 Fax +86-351-7117522 taiyuan@sew-eurodrive.cn
	Wuhan	SEW-EURODRIVE (Wuhan) Co., Ltd. 10A-2, 6th Road No. 59, the 4th Quanli Road, WEDA 430056 Wuhan	Tel. +86 27 84478388 Fax +86 27 84478389 wuhan@sew-eurodrive.cn
	Xi'An	SEW-EURODRIVE (Xi'An) Co., Ltd. No. 12 Jinye 2nd Road Xi'An High-Technology Industrial Development Zone Xi'An 710065	Tel. +86 29 68686262 Fax +86 29 68686311 xian@sew-eurodrive.cn
Sales Service	Hong Kong	SEW-EURODRIVE LTD. Unit No. 801-806, 8th Floor Hong Leong Industrial Complex No. 4, Wang Kwong Road Kowloon, Hong Kong	Tel. +852 36902200 Fax +852 36902211 contact@sew-eurodrive.hk

Colombia			
Assembly Sales Service	Bogota	SEW-EURODRIVE COLOMBIA LTDA. Calle 17 No. 132-18 Interior 2 Bodega 6, Manzana B Santafé de Bogotá	Tel. +57 1 54750-50 Fax +57 1 54750-44 http://www.sew-eurodrive.com.co sew@sew-eurodrive.com.co
Croatia			
Sales Service	Zagreb	KOMPEKS d. o. o. Zeleni dol 10 10 000 Zagreb	Tel. +385 1 4613-158 Fax +385 1 4613-158 kompeks@inet.hr
Czech Republic			
Assembly Sales Service	Hostivice	SEW-EURODRIVE CZ s.r.o. Floriánova 2459 253 01 Hostivice	Tel. +420 255 709 601 Fax +420 235 350 613 http://www.sew-eurodrive.cz sew@sew-eurodrive.cz
Denmark			
Assembly Sales Service	Copenhagen	SEW-EURODRIVE A/S Geminivej 28-30 2670 Greve	Tel. +45 43 95 8500 Fax +45 43 9585-09 http://www.sew-eurodrive.dk sew@sew-eurodrive.dk
Service	Vejle	SEW-EURODRIVE A/S Bødkervej 2 7100 Vejle	Tel. +45 43 9585 00 http://www.sew-eurodrive.dk sew@sew-eurodrive.dk
Egypt			
Technical Office	Cairo	SEW-EURODRIVE Representative Office in Egypt REGUS Paramount Business Complex, Block 1258M, Unit 1, Ground Floor, Sheraton Heli- opolis Cairo	Tel. +20 2 2503 2807 Fax +20 2 2503 2801 info@sew-eurodrive.eg
Estonia			
Sales	Tallin	ALAS-KUUL AS Loomäe tee 1, Lehmja küla 75306 Rae vald Harjumaa	Tel. +372 6593230 Fax +372 6593231 http://www.alas-kuul.ee info@alas-kuul.ee
Finland			
Assembly Sales Service	Hollola	SEW-EURODRIVE OY Vesimäentie 4 15860 Hollola	Tel. +358 201 589-300 Fax +358 3 780-6211 http://www.sew-eurodrive.fi sew@sew.fi
Service	Hollola	SEW-EURODRIVE OY Keskikankaantie 21 15860 Hollola	Tel. +358 201 589-300 Fax +358 3 780-6211 http://www.sew-eurodrive.fi sew@sew.fi
Service	Tornio	SEW-EURODRIVE Oy Lossirannankatu 5 95420 Tornio	Tel. +358 201 589 300 Fax +358 3 780 6211 http://www.sew-eurodrive.fi sew@sew.fi
Production Assembly	Karkkila	SEW Industrial Gears Oy Santasalonkatu 6, PL 8 03620 Karkkila, 03601 Karkkila	Tel. +358 201 589-300 Fax +358 201 589-310 http://www.sew-eurodrive.fi sew@sew.fi
France			
Production Sales	Haguenau	SEW USOCOME 48-54 route de Soufflenheim B. P. 20185 67506 Haguenau Cedex	Tel. +33 3 88 73 67 00 http://www.usocom.com sew@usocom.com
Production	Forbach	SEW USOCOME Zone industrielle Technopôle Forbach Sud B. P. 30269 57604 Forbach Cedex	Tel. +33 3 87 29 38 00

France			
	Brumath	SEW USOCOME 1 Rue de Bruxelles 67670 Mommenheim Cedex	Tel. +33 3 88 37 48 00
Assembly Sales Service	Bordeaux	SEW USOCOME Parc d'activités de Magellan 62 avenue de Magellan – B. P. 182 33607 Pessac Cedex	Tel. +33 5 57 26 39 00 dtcbordeaux@usocome.com
	Haguenau	SEW USOCOME 48-54 route de Soufflenheim B. P. 20185 67506 Haguenau Cedex	Tel. +33 3 88 73 67 00 dtchaguenau@usocome.com
	Lyon	SEW USOCOME 75 rue Antoine Condorcet 38090 Vaulx-Milieu	Tel. +33 4 74 99 60 00 dtclyon@usocome.com
	Nantes	SEW USOCOME Parc d'activités de la forêt 4 rue des Fontenelles 44140 Le Bignon	Tel. +33 2 40 78 42 00 dtcnantes@usocome.com
	Paris	SEW USOCOME Zone industrielle 2 rue Denis Papin 77390 Verneuil l'Étang	Tel. +33 1 64 42 40 80 dtcparis@usocome.com

Gabon

Representation: Cameroon

Germany

Headquarters Production Sales	Bruchsal	SEW-EURODRIVE GmbH & Co KG Ernst-Blickle-Straße 42 76646 Bruchsal	Tel. +49 7251 75-0 Fax +49 7251 75-1970 http://www.sew-eurodrive.de sew@sew-eurodrive.de
Production / Industrial Gears	Bruchsal	SEW-EURODRIVE GmbH & Co KG Christian-Pähr-Str. 10 76646 Bruchsal	Tel. +49 7251 75-0 Fax +49 7251 75-2970
Production / Precision Gear Units	Bruchsal	SEW-EURODRIVE GmbH & Co KG Ernst-Blickle-Straße 42 76646 Bruchsal	Tel. +49 7251 75-0 Fax +49 7251 75-1970 sew@sew-eurodrive.de
Production	Graben	SEW-EURODRIVE GmbH & Co KG Ernst-Blickle-Straße 1 76676 Graben-Neudorf	Tel. +49 7251 75-0 Fax +49 7251-2970
Service Competence Center	Mechanics / Mechatronics	SEW-EURODRIVE GmbH & Co KG Ernst-Blickle-Straße 1 76676 Graben-Neudorf	Tel. +49 7251 75-1710 Fax +49 7251 75-1711 scc-mechanik@sew-eurodrive.de
	Electronics	SEW-EURODRIVE GmbH & Co KG Christian-Pähr-Straße 12 76646 Bruchsal	Tel. +49 7251 75-1780 Fax +49 7251 75-1769 scc-elektronik@sew-eurodrive.de
Drive Technology Center	MAXOLU- TION® Factory Automation	SEW-EURODRIVE GmbH & Co KG Eisenbahnstraße 11 76646 Bruchsal	Tel. +49 7251 75-0 Fax +49 7251 75-1970 sew@sew-eurodrive.de
	North	SEW-EURODRIVE GmbH & Co KG Alte Ricklinger Straße 43 30823 Garbsen (Hannover)	Tel. +49 5137 8798-30 Fax +49 5137 8798-55 dtc-nord@sew-eurodrive.de
	East	SEW-EURODRIVE GmbH & Co KG Dänkritzer Weg 1 08393 Meerane (Zwickau)	Tel. +49 3764 7606-0 Fax +49 3764 7606-20 dtc-ost@sew-eurodrive.de
	South	SEW-EURODRIVE GmbH & Co KG Domagkstraße 5 85551 Kirchheim (München)	Tel. +49 89 909551-21 Fax +49 89 909551-50 dtc-sued@sew-eurodrive.de
	West	SEW-EURODRIVE GmbH & Co KG Siemensstraße 1 40764 Langenfeld (Düsseldorf)	Tel. +49 2173 8507-10 Fax +49 2173 8507-50 dtc-west@sew-eurodrive.de
Drive Center	Berlin	SEW-EURODRIVE GmbH & Co KG Melitta-Schiller-Straße 8 12526 Berlin	Tel. +49 306331131-30 Fax +49 306331131-36 dc-berlin@sew-eurodrive.de

Germany			
	Bremen	SEW-EURODRIVE GmbH & Co KG Allerkai 4 28309 Bremen	Tel. +49 421 33918-10 Fax +49 421 33918-22 dc-bremen@sew-eurodrive.de
	Hamburg	SEW-EURODRIVE GmbH & Co KG Hasselbinnen 11 22869 Schenefeld	Tel. +49 40298109-60 Fax +49 40298109-70 dc-hamburg@sew-eurodrive.de
	Saarland	SEW-EURODRIVE GmbH & Co KG Gottlieb-Daimler-Straße 4 66773 Schwalbach Saar – Hülzweiler	Tel. +49 6831 48946 10 Fax +49 6831 48946 13 dc-saarland@sew-eurodrive.de
	Ulm	SEW-EURODRIVE GmbH & Co KG Dieselstraße 18 89160 Dornstadt	Tel. +49 7348 9885-0 Fax +49 7348 9885-90 dc-ulm@sew-eurodrive.de
	Würzburg	SEW-EURODRIVE GmbH & Co KG Nürnbergerstraße 118 97076 Würzburg-Lengfeld	Tel. +49 931 27886-60 Fax +49 931 27886-66 dc-wuerzburg@sew-eurodrive.de
Drive Service Hotline / 24 Hour Service			0 800 SEWHELP 0 800 7394357
Great Britain			
Assembly Sales Service	Normanton	SEW-EURODRIVE Ltd. DeVilliers Way Trident Park Normanton West Yorkshire WF6 1GX	Tel. +44 1924 893-855 Fax +44 1924 893-702 http://www.sew-eurodrive.co.uk info@sew-eurodrive.co.uk
Greece			
Sales	Athens	Christ. Boznos & Son S.A. 12, K. Mavromichali Street P.O. Box 80136 18545 Piraeus	Tel. +30 2 1042 251-34 Fax +30 2 1042 251-59 http://www.boznos.gr info@boznos.gr
Hungary			
Sales Service	Budapest	SEW-EURODRIVE Kft. Csillaghegyi út 13. 1037 Budapest	Tel. +36 1 437 06-58 Fax +36 1 437 06-50 http://www.sew-eurodrive.hu office@sew-eurodrive.hu
Iceland			
Sales	Reykjavik	Varma & Vélaverk ehf. Knarrarvogi 4 104 Reykjavik	Tel. +354 585 1070 Fax +354 585)1071 https://vov.is/ vov@vov.is
India			
Registered Office Assembly Sales Service	Vadodara	SEW-EURODRIVE India Private Limited 302, NOTUS IT PARK, Sarabhai Campus, Beside Notus Pride, Genda Circle, Vadodara 390023 Gujarat	Tel. +91 265 3045200 Fax +91 265 3045300 https://www.seweurodriveindia.com salesvadodara@seweurodriveindia.com
Assembly Sales Service	Chennai	SEW-EURODRIVE India Private Limited Plot No. K3/1, Sipcot Industrial Park Phase II Mambakkam Village Sriperumbudur - 602105 Kancheepuram Dist, Tamil Nadu	Tel. +91 44 37188888 Fax +91 44 37188811 saleschennai@seweurodriveindia.com
	Pune	SEW-EURODRIVE India Private Limited Plant: Plot No. D236/1, Chakan Industrial Area Phase- II, Warale, Tal- Khed, Pune-410501, Maharashtra	Tel. +91 21 35 628700 Fax +91 21 35 628715 salespune@seweurodriveindia.com
	Tapukara	SEW-EURODRIVE India Private Limited Plot No SP-6-46, Tapukara, Karoli Industrial Area, No. 1, district : Alwar , Rajasthan - 301707	Tel. +91 265 3045200 Fax +91 265 3045300 tapukara.plant@seweurodriveindia.com

India			
Sales	Gurgaon	SEW-EURODRIVE India Private Limited Global Business Park, Sector -26, M.G. Road, Sikanderpur Unit No. 205, 2nd Floor, Tower – D Gurugram 122002, Haryana	Tel. +91 9958376669 salesgurgaon@seweurodriveindia.com
Indonesia			
Registered Office Sales Service	Jakarta	PT SEW EURODRIVE INDONESIA Palma Tower, 16th Floor, Unit H & I, Jl R.A. Kartini II-S Kav 06 Pondok Pinang, Kebayoran Lama Jakarta Selatan 12310	Tel. +62 21 7593 0272 Fax +62 21 7593 0273 sales.indonesia@sew-eurodrive.com https://www.sew-eurodrive.com.sg
Sales	Medan	PT. Serumpun Indah Lestari Jl.Pulau Solor no. 8, Kawasan Industri Medan II Medan 20252	Tel. +62 61 687 1221 Fax +62 61 6871429 / +62 61 6871458 / +62 61 30008041 sil@serumpunindah.com serumpunindah@yahoo.com http://www.serumpunindah.com
	Jakarta	PT. Cahaya Sukses Abadi Komplek Rukan Puri Mutiara Blok A no 99, Sunter Jakarta 14350	Tel. +62 21 65310599 Fax +62 21 65310600 csajkt@cbn.net.id
	Jakarta	PT. Agrindo Putra Lestari Jl.Pantai Indah Selatan, Komplek Sentra In- dustri Terpadu, Pantai indah Kapuk Tahap III, Blok E No. 27 Jakarta 14470	Tel. +62 21 2921-8899 Fax +62 21 2921-8988 aplindo@indosat.net.id http://www.aplindo.com
	Surabaya	PT. TRIAGRI JAYA ABADI Jl. Sukosemolo No. 63, Galaxi Bumi Permai G6 No. 11 Surabaya 60111	Tel. +62 31 5990128 Fax +62 31 5962666 sales@triagri.co.id http://www.triagri.co.id
	Surabaya	CV. Multi Mas Jl. Raden Saleh 43A Kav. 18 Surabaya 60174	Tel. +62 31 5458589 Fax +62 31 5317220 sianhwa@sby.centrin.net.id http://www.cvmultimas.com
Ireland			
Sales Service	Dublin	Alperton Engineering Ltd. 48 Moyle Road Dublin Industrial Estate Glasnevin, Dublin 11	Tel. +353 1 830-6277 Fax +353 1 830-6458 http://www.alperton.ie info@alperton.ie
Israel			
Sales	Tel Aviv	Liraz Handasa Ltd. Ahofer Str 34B / 228 58858 Holon	Tel. +972 3 5599511 Fax +972 3 5599512 http://www.liraz-handasa.co.il office@liraz-handasa.co.il
Italy			
Assembly Sales Service	Milan	SEW-EURODRIVE S.a.s. di SEW S.r.l. & Co. Via Bernini,12 20033 Solaro (Milano)	Tel. +39 02 96 980229 Fax +39 02 96 980 999 http://www.sew-eurodrive.it milano@sew-eurodrive.it
Ivory Coast			
Sales	Abidjan	SEW-EURODRIVE SARL Ivory Coast Rue des Pêcheurs, Zone 3 26 BP 916 Abidjan 26	Tel. +225 27 21 21 81 05 Fax +225 27 21 25 30 47 info@sew-eurodrive.ci http://www.sew-eurodrive.ci
Japan			
Assembly Sales Service	Iwata	SEW-EURODRIVE JAPAN CO., LTD 250-1, Shimoman-no, Iwata Shizuoka 438-0818	Tel. +81 538 373811 Fax +81 538 373814 http://www.sew-eurodrive.co.jp sewjapan@sew-eurodrive.co.jp

Kazakhstan			
Sales Service	Almaty	SEW-EURODRIVE LLP 291-291A, Tole bi street 050031, Almaty	Tel. +7 (727) 350 5156 Fax +7 (727) 350 5156 http://www.sew-eurodrive.com kazakhstan@sew-eurodrive.com
	Tashkent	Representative Office SEW-EURODRIVE Representative office in Uzbekistan 95A Amir Temur ave, office 401/3 100084 Tashkent	Tel. +998 97 134 01 99 http://www.sew-eurodrive.uz sew@sew-eurodrive.uz
	Ulaanbaatar	IM Trading LLC Olympic street 28B/3 Sukhbaatar district, Ulaanbaatar 14230, MN	Tel. +976-77109997 Fax +976-77109997 imt@imt.mn
Latvia			
Sales	Riga	SIA Alas-Kuul Katlakalna 11C 1073 Riga	Tel. +371 6 7139253 Fax +371 6 7139386 http://www.alas-kuul.lv info@alas-kuul.com
Lebanon			
Sales (Lebanon)	Beirut	Gabriel Acar & Fils sarl B. P. 80484 Bourj Hammoud, Beirut	Tel. +961 1 510 532 Fax +961 1 494 971 ssacar@inco.com.lb
Sales (Jordan, Kuwait , Beirut Saudi Arabia, Syria)		Middle East Drives S.A.L. (offshore) Sin El Fil. B. P. 55-378 Beirut	Tel. +961 1 494 786 Fax +961 1 494 971 http://www.medrives.com info@medrives.com
Lithuania			
Sales	Alytus	UAB Irseva Statybininku 106C 63431 Alytus	Tel. +370 315 79204 Fax +370 315 56175 http://www.irseva.lt irmantas@irseva.lt
Luxembourg			
Representation: Belgium			
Macedonia			
Sales	Skopje	Boznos DOOEL Dime Anicin 2A/7A 1000 Skopje	Tel. +389 23256553 Fax +389 23256554 http://www.boznos.mk
Malaysia			
Assembly Sales Service	Johor	SEW-EURODRIVE SDN BHD No. 95, Jalan Seroja 39, Taman Johor Jaya 81000 Johor Bahru, Johor West Malaysia	Tel. +60 7 3549409 Fax +60 7 3541404 sales@sew-eurodrive.com.my
Mexico			
Assembly Sales Service	Quéretaro	SEW-EURODRIVE MEXICO S.A. de C.V. SEM-981118-M93 Tequisquiapan No. 102 Parque Industrial Quéretaro C.P. 76220 Querétaro, México	Tel. +52 442 1030-300 Fax +52 442 1030-301 http://www.sew-eurodrive.com.mx scmexico@seweurodrive.com.mx
Sales Service	Puebla	SEW-EURODRIVE MEXICO S.A. de C.V. Calzada Zavaleta No. 3922 Piso 2 Local 6 Col. Santa Cruz Buenavista C.P. 72154 Puebla, México	Tel. +52 (222) 221 248 http://www.sew-eurodrive.com.mx scmexico@seweurodrive.com.mx
Mongolia			
Technical Office	Ulaanbaatar	IM Trading LLC Olympic street 28B/3 Sukhbaatar district, Ulaanbaatar 14230, MN	Tel. +976-77109997 Tel. +976-99070395 Fax +976-77109997 http://imt.mn/ imt@imt.mn

Morocco			
Sales Service Assembly	Bouskoura	SEW-EURODRIVE Morocco SARL Parc Industriel CFCIM, Lot. 55/59 27182 Bouskoura Grand Casablanca	Tel. +212 522 88 85 00 Fax +212 522 88 84 50 http://www.sew-eurodrive.ma sew@sew-eurodrive.ma
Namibia			
Sales	Swakopmund	DB MINING & INDUSTRIAL SUPPLIES CC Einstein Street Strauss Industrial Park Unit1 Swakopmund	Tel. +264 64 462 738 Fax +264 64 462 734 anton@dbminingnam.com
Netherlands			
Assembly Sales Service	Rotterdam	SEW-EURODRIVE B.V. Industrieweg 175 3044 AS Rotterdam Postbus 10085 3004 AB Rotterdam	Tel. +31 10 4463-700 Fax +31 10 4155-552 Service: 0800-SEWHELP http://www.sew-eurodrive.nl info@sew-eurodrive.nl
New Zealand			
Assembly Sales Service	Auckland	SEW-EURODRIVE NEW ZEALAND LTD. P.O. Box 58-428 82 Greenmount drive East Tamaki Auckland	Tel. +64 9 2745627 Fax +64 9 2740165 http://www.sew-eurodrive.co.nz sales@sew-eurodrive.co.nz
	Christchurch	SEW-EURODRIVE NEW ZEALAND LTD. 30 Lodestar Avenue, Wigram Christchurch	Tel. +64 3 384-6251 Fax +64 3 384-6455 sales@sew-eurodrive.co.nz
Nigeria			
Sales	Lagos	Greenpeg Nig. Ltd 64C Toyin Street Opebi-Allen Ikeja Lagos-Nigeria	Tel. +234-701-821-9200-1 http://www.greenpeg ltd.com sales@greenpeg ltd.com
Norway			
Assembly Sales Service	Moss	SEW-EURODRIVE A/S Hornebergvegen 11 B 7038 Trondheim	Tel. +47 69 24 10 20 Fax +47 69 24 10 40 http://www.sew-eurodrive.no sew@sew-eurodrive.no
Pakistan			
Sales	Karachi	Industrial Power Drives Al-Fatah Chamber A/3, 1st Floor Central Com- mercial Area, Sultan Ahmed Shah Road, Block 7/8, Karachi	Tel. +92 21 452 9369 Fax +92-21-454 7365 seweurodrive@cyber.net.pk
Paraguay			
Sales	Fernando de la Mora	SEW-EURODRIVE PARAGUAY S.R.L Nu Guazu No. 642 casi Campo Esperanza Santisima Trinidad Asuncion	Tel. +595 991 519695 Fax +595 21 3285539 sewpy@sew-eurodrive.com.py
Peru			
Assembly Sales Service	Lima	SEW EURODRIVE DEL PERU S.A.C. Los Calderos, 120-124 Urbanizacion Industrial Vulcano, ATE, Lima	Tel. +51 1 3495280 Fax +51 1 3493002 http://www.sew-eurodrive.com.pe sewperu@sew-eurodrive.com.pe
Philippines			
Sales	Makati	P.T. Cerna Corporation 4137 Ponte St., Brgy. Sta. Cruz Makati City 1205	Tel. +63 2 519 6214 Fax +63 2 890 2802 mech_drive_sys@ptcerna.com http://www.ptcerna.com
Poland			
Assembly Sales Service	Łódź	SEW-EURODRIVE Polska Sp.z.o.o. ul. Techniczna 5 92-518 Łódź	Tel. +48 42 293 00 00 Fax +48 42 293 00 49 http://www.sew-eurodrive.pl sew@sew-eurodrive.pl

Poland			
	Service	Tel. +48 42 293 0030 Fax +48 42 293 0043	24 Hour Service Tel. +48 602 739 739 (+48 602 SEW SEW) serwis@sew-eurodrive.pl
Portugal			
Assembly Sales Service	Coimbra	SEW-EURODRIVE, LDA. Av. da Fonte Nova, n.º 86 3050-379 Mealhada	Tel. +351 231 20 9670 Fax +351 231 20 3685 http://www.sew-eurodrive.pt infosew@sew-eurodrive.pt
Romania			
Sales Service	Bucharest	Sialco Trading SRL str. Brazilia nr. 36 011783 Bucuresti	Tel. +40 21 230-1328 Fax +40 21 230-7170 http://www.sialco.ro sialco@sialco.ro
Senegal			
Sales	Dakar	SENEMECA Mécanique Générale Km 8, Route de Rufisque B.P. 3251, Dakar	Tel. +221 338 494 770 Fax +221 338 494 771 http://www.senemeca.com senemeca@senemeca.sn
Serbia			
Sales	Belgrade	DIPAR d.o.o. Ustanicka 128a PC Košum, IV floor 11000 Beograd	Tel. +381 11 347 3244 / +381 11 288 0393 Fax +381 11 347 1337 office@dipar.rs
Singapore			
Assembly Sales Service	Singapore	SEW-EURODRIVE PTE. LTD. 9, Tuas Drive 2 Singapore 638644	Tel. +65 68621701 Fax +65 68612827 http://www.sew-eurodrive.com.sg sewsingapore@sew-eurodrive.com
Slovakia			
Drive Technology Center	Bernolákovo	SEW-Eurodrive SK s.r.o. Priemyselna ulica 6267/7 900 27 Bernolákovo	Tel.+421 2 48 212 800 http://www.sew-eurodrive.sk sew@sew-eurodrive.sk
Slovenia			
Sales Service	Celje	Pakman - Pogonska Tehnika d.o.o. Ul. XIV. divizije 14 3000 Celje	Tel. +386 3 490 83-20 Fax +386 3 490 83-21 pakman@siol.net
South Africa			
Assembly Sales Service	Johannesburg	SEW-EURODRIVE (PROPRIETARY) LIMITED 32 O'Connor Place Eurodrive House Aeroton Johannesburg 2190 P.O.Box 90004 Bertsham 2013	Tel. +27 11 248-7000 Fax +27 11 248-7289 http://www.sew.co.za info@sew.co.za
	Cape Town	SEW-EURODRIVE (PROPRIETARY) LIMITED Rainbow Park Cnr. Racecourse & Omuramba Road Montague Gardens Cape Town P.O.Box 36556 Chempet 7442	Tel. +27 21 552-9820 Fax +27 21 552-9830 Telex 576 062 bgriffiths@sew.co.za
	Durban	SEW-EURODRIVE (PROPRIETARY) LIMITED 48 Prospecton Road Isipingo Durban P.O. Box 10433, Ashwood 3605	Tel. +27 31 902 3815 Fax +27 31 902 3826 cdejager@sew.co.za
	Nelspruit	SEW-EURODRIVE (PROPRIETARY) LIMITED 7 Christie Crescent Vintonia P.O.Box 1942 Nelspruit 1200	Tel. +27 13 752-8007 Fax +27 13 752-8008 robermeyer@sew.co.za

South Korea			
Assembly Sales Service	Ansan	SEW-EURODRIVE Korea Co., Ltd. 7, Dangjaengi-ro, Danwon-gu, Ansan-si, Gyeonggi-do, Zip 425-839	Tel. +82 31 492-8051 Fax +82 31 492-8056 http://www.sew-eurodrive.kr master.korea@sew-eurodrive.com
	Busan	SEW-EURODRIVE Korea Co., Ltd. 28, Noksansandan 262-ro 50beon-gil, Gangseo-gu, Busan, Zip 618-820	Tel. +82 51 832-0204 Fax +82 51 832-0230
Assembly Service	Siheung	SEW-EURODRIVE Korea Co., Ltd. 35, Emtibeui 26-ro 58beon-gil, Siheung-si, Gyeonggi-do	http://www.sew-eurodrive.kr
Spain			
Assembly Sales Service	Bilbao	SEW-EURODRIVE ESPAÑA, S.L. Parque Tecnológico, Edificio, 302 48170 Zamudio (Vizcaya)	Tel. +34 94 43184-70 http://www.sew-eurodrive.es sew.spain@sew-eurodrive.es
Sri Lanka			
Sales	Colombo	SM International (Pte) Ltd 254, Galle Raod Colombo 4, Sri Lanka	Tel. +94 1 2584887 Fax +94 1 2582981
Swaziland			
Sales	Manzini	C G Trading Co. (Pty) Ltd Simunye street Matsapha, Manzini	Tel. +268 7602 0790 Fax +268 2 518 5033 charles@cgtrading.co.sz www.cgtradingswaziland.com
Sweden			
Assembly Sales Service	Jönköping	SEW-EURODRIVE AB Gnejsvägen 6-8 553 03 Jönköping Box 3100 S-550 03 Jönköping	Tel. +46 36 34 42 00 Fax +46 36 34 42 80 http://www.sew-eurodrive.se jonkoping@sew.se
Switzerland			
Assembly Sales Service	Basel	Alfred Imhof A.G. Jurastrasse 10 4142 Münchenstein bei Basel	Tel. +41 61 417 1717 Fax +41 61 417 1700 http://www.imhof-sew.ch info@imhof-sew.ch
Taiwan			
Sales	Taipei	Ting Shou Trading Co., Ltd. 6F-3, No. 267, Sec. 2 Tung Huw S. Road Taipei	Tel. +886 2 27383535 Fax +886 2 27368268 Telex 27 245 sewtwn@ms63.hinet.net http://www.tingshou.com.tw
	Nan Tou	Ting Shou Trading Co., Ltd. No. 55 Kung Yeh N. Road Industrial District Nan Tou 540	Tel. +886 49 255353 Fax +886 49 257878 sewtwn@ms63.hinet.net http://www.tingshou.com.tw
Tanzania			
Sales	Daressalam	SEW-EURODRIVE PTY LIMITED TANZANIA Plot 52, Regent Estate PO Box 106274 Dar Es Salaam	Tel. +255 0 22 277 5780 Fax +255 0 22 277 5788 http://www.sew-eurodrive.co.tz info@sew.co.tz
Thailand			
Assembly Sales Service	Chonburi	SEW-EURODRIVE (Thailand) Ltd. 700/456, Moo.7, Donhuaroh Muang Chonburi 20000	Tel. +66 38 454281 Fax +66 38 454288 sewthailand@sew-eurodrive.com https://www.sew-eurodrive.co.th
Tunisia			
Sales	Tunis	T. M.S. Technic Marketing Service Zone Industrielle Mghira 2 Lot No. 39 2082 Fouchana	Tel. +216 79 40 88 77 Fax +216 79 40 88 66 http://www.tms.com.tn tms@tms.com.tn

Turkey			
Assembly Sales Service	Kocaeli-Gebze	SEW-EURODRIVE Ana Merkez Gebze Organize Sanayi Böl. 400 Sok No. 401 41480 Gebze Kocaeli	Tel. +90 262 9991000 04 Fax +90 262 9991009 http://www.sew-eurodrive.com.tr sew@sew-eurodrive.com.tr
Ukraine			
Assembly Sales Service	Dnipropetrovsk	SEW-EURODRIVE, LLC Robochya str., bld. 23-B, office 409 49008 Dnipro	Tel. +380 56 370 3211 Fax +380 56 372 2078 http://www.sew-eurodrive.ua sew@sew-eurodrive.ua
United Arab Emirates			
Drive Technology Center	Dubai	SEW-EURODRIVE FZE PO Box 263835 Jebel Ali Free Zone – South, P.O. Box Dubai, United Arab Emirates	Tel. +971 (0)4 8806461 Fax +971 (0)4 8806464 info@sew-eurodrive.ae
Uruguay			
Assembly Sales	Montevideo	SEW-EURODRIVE Uruguay, S. A. Jose Serrato 3569 Esquina Corumbe CP 12000 Montevideo	Tel. +598 2 21181-89 Fax +598 2 21181-90 sewuy@sew-eurodrive.com.uy
USA			
Production Sales Service	Southeast Region	SEW-EURODRIVE INC. 1295 Old Spartanburg Highway P.O. Box 518 Lyman, S.C. 29365	Tel. +1 864 439-7537 Fax Sales +1 864 439-7830 Fax Production +1 864 439-9948 Fax Assembly +1 864 439-0566 Fax Confidential/HR +1 864 949-5557 http://www.seweurodrive.com cslyman@seweurodrive.com
Assembly Sales Service	Northeast Region	SEW-EURODRIVE INC. Pureland Ind. Complex 2107 High Hill Road, P.O. Box 481 Bridgeport, New Jersey 08014	Tel. +1 856 467-2277 Fax +1 856 845-3179 csbridgeport@seweurodrive.com
	Midwest Region	SEW-EURODRIVE INC. 2001 West Main Street Troy, Ohio 45373	Tel. +1 937 335-0036 Fax +1 937 332-0038 cstroy@seweurodrive.com
	Southwest Region	SEW-EURODRIVE INC. 202 W. Daniieldale Rd. DeSoto, TX 75115	Tel. +1 214 330-4824 Fax +1 214 330-4724 csdallas@seweurodrive.com
	Western Region	SEW-EURODRIVE INC. 30599 San Antonio St. Hayward, CA 94544	Tel. +1 510 487-3560 Fax +1 510 487-6433 cshayward@seweurodrive.com
	Wellford	SEW-EURODRIVE INC. 148/150 Finch Rd. Wellford, S.C. 29385	Tel. +1 864 439-7537 Fax +1 864 661 1167 IGOrders@seweurodrive.com
		SEW-EURODRIVE INC. 220 Finch Rd. Wellford, S.C. 29385-9630	
Additional addresses for service provided on request!			
Vietnam			
Sales	Ho Chi Minh City	SEW-EURODRIVE PTE. LTD. RO at Hochim- inh City Floor 8, KV I, Loyal building, 151-151 Bis Vo Thi Sau street, ward 6, District 3, Ho Chi Minh City, Vietnam	Tel. +84 937 299 700 huytam.phan@sew-eurodrive.com
	Hanoi	MICO LTD Quảng Trị - North Vietnam / All sectors except Construction Materials 8th Floor, Ocean Park Building, 01 Dao Duy Anh St, Ha Noi, Viet Nam	Tel. +84 4 39386666 Fax +84 4 3938 6888 nam_ph@micogroup.com.vn http://www.micogroup.com.vn
Zambia			
Representation: South Africa			

Index

A

Adapter	
Attachment	45
EBH.....	12, 13, 14, 45
ECH.....	16
EPH.....	15, 45
Adapter EPH	18
Adapters EBH., EPH., ECH....	
Permitted motor weight	50

B

Bearing greases	59
Breather valve	28
Activate.....	29
BS.F..	
Fill quantities	65
Fill quantities dependent on mounting position	65
Fill quantity tolerances.....	65
Gear unit structure.....	14
Installation	31
BSBF..	
Gear unit structure.....	13
BSF..	
Gear unit structure.....	12
BSHF..	
Gear unit structure.....	14

C

Changing the mounting position	26
PS.F.	26
Clamping set	37
Copyright notice	7

D

Damp locations.....	28
Decimal separator	7
Designated use	9
Directions of rotation	23

E

EBH..	
Adapter.....	12, 13, 14
Motor mounting	45

EBH., EPH., ECH..	
Permitted motor weight.....	50
ECH..	
Adapter	16
Motor mounting.....	48
Embedded safety notes	7
EPH adapter	18
EPH..	
Adapter	15
Motor mounting.....	45
Extended storage.....	69

F

Fill quantities	
BS.F.....	65
PS.F.....	66
Fill quantities dependent on mounting position	
BS.F.....	65
PS.F.....	66
Fill quantity tolerances	
BS.F.....	65
Flange block shaft	
Mounting	38
Flatness defect	26
Foot mounting	32
Friction coefficient	
Tightening torque.....	27

G

Gear unit	
Mounting	25
Painting.....	30
Venting.....	28
Gear unit structure	12
BSAF..	14
BSBF..	13
BSF.....	12
BSHF..	14
PSBF..	15
PSC..	16
PSCZ..	16
PSF.....	15
Grease filling	59

I

Information

- Designation in the documentation 6
- Initial startup 53
- Inner centering ring 38
- Inspection 55
- Installation
 - BS.F.. 31
 - Gear unit mounting 25
 - In damp locations or outdoors 28
 - Requirements 21
- Installation in the machine
 - PS.C. 34
- Installation in the system
 - PS.F.. 33
- Inverter operation 53

L

- Limit speed 53
- Lubricant fill quantities 65
- Lubricant table 59
- Lubricants
 - Change intervals 58
 - Compatibility with oil seal 61
 - Lubricant table 59

M

- Maintenance 55
- Maintenance intervals 56
- Malfunctions 84
- Motor
 - Removing 52
- Motor adapter 53
- Motor mounting
 - EBH.. 45
 - EPH.. 45
- Motor mounting via ECH.. adapter 48
- motor weight
 - Permitted 50
- Mounting
 - Couplings 38
 - Flange block shaft 38
 - Motor mounting 45
 - Motor via EBH.. and EPH.. adapters 45
 - Output elements onto solid shafts 35

- Requirements 21
- shrink disks 41
- Smooth solid shaft 37
- Solid shaft with key 35
- Torque arm on BS.F.. shaft-mounted gear units
 - 39
 - with mounting device 35
- Mounting device 35
- Mounting of couplings 38
- Mounting output elements onto solid shafts 35
- Mounting position M0 26
- Mounting position sheets
 - Information 72
- Mounting positions
 - Icons 72

N

- Normal operation 53

O

- Oil quantity 65
- Oil seals
 - Lubricant compatibility 61
- Oil temperature 54
- Operation
 - Initial startup 53
- Outer centering ring 38
- Overhung load
 - Gear wheel or sprocket installation 36

P

- Painting the gear unit 30
- Permitted motor weight
 - Adapters EBH., EPH., ECH.. 50
- Pivoted mounting position 28
- Product names 7
- PS.C..
 - Installation in the machine 34
- PS.F..
 - Changing the mounting position 26
 - Fill quantities 66
 - Fill quantities dependent on mounting position
 - 66
 - Installation in the system 33
- PSBF..
 - Gear unit structure 15

PSC..		Stainless shrink disk or output shaft	
Gear unit structure.....	16	Notes	10, 11
PSCZ..		Stainless steel shrink disk or output shaft	
Gear unit structure.....	16	Notes	10, 11
PSF..		Startup	53
Gear unit structure.....	15	Measuring the oil temperature	54
R		Storage	10
Radial load		Storage conditions	69
Gear wheel or sprocket installation	36	System	
Removing EBH.., EPH.. or ECH.. adapters.....	52	Installation of PS.C.. gear unit	34
Repair	84	Installation of PS.F.. gear unit.....	33
Rights to claim under limited warranty	7	T	
S		Target group	9
Safety notes		Test mode.....	53
Designated use	9	Tightening torque	
Preliminary information.....	8	Friction coefficient.....	27
Storage.....	10	Tool.....	27
Structure of section-related	6	Tightening torques	27, 28
Transport.....	10	Breather valves, oil sight glasses	28
Screws.....	27	Oil level, oil drain, and screw plug	28
Section-related safety notes	6	Tolerances, shafts and flanges.....	22
Service	84	Torque arm	
Shaft-mounted gear unit		on BS.F.. shaft-mounted gear units.....	39
Keyway.....	40	Trademarks.....	7
Shrink disk		Transport	10
Cleaning	44	U	
Lubrication.....	44	Universal mounting position.....	26
Shrink disks, (removal) mounting	41	W	
Signal words in safety notes.....	6	Warning notes	
Skew.....	28	Designation in the documentation	6
Solvent	21	Structure of the embedded safety notes.....	7

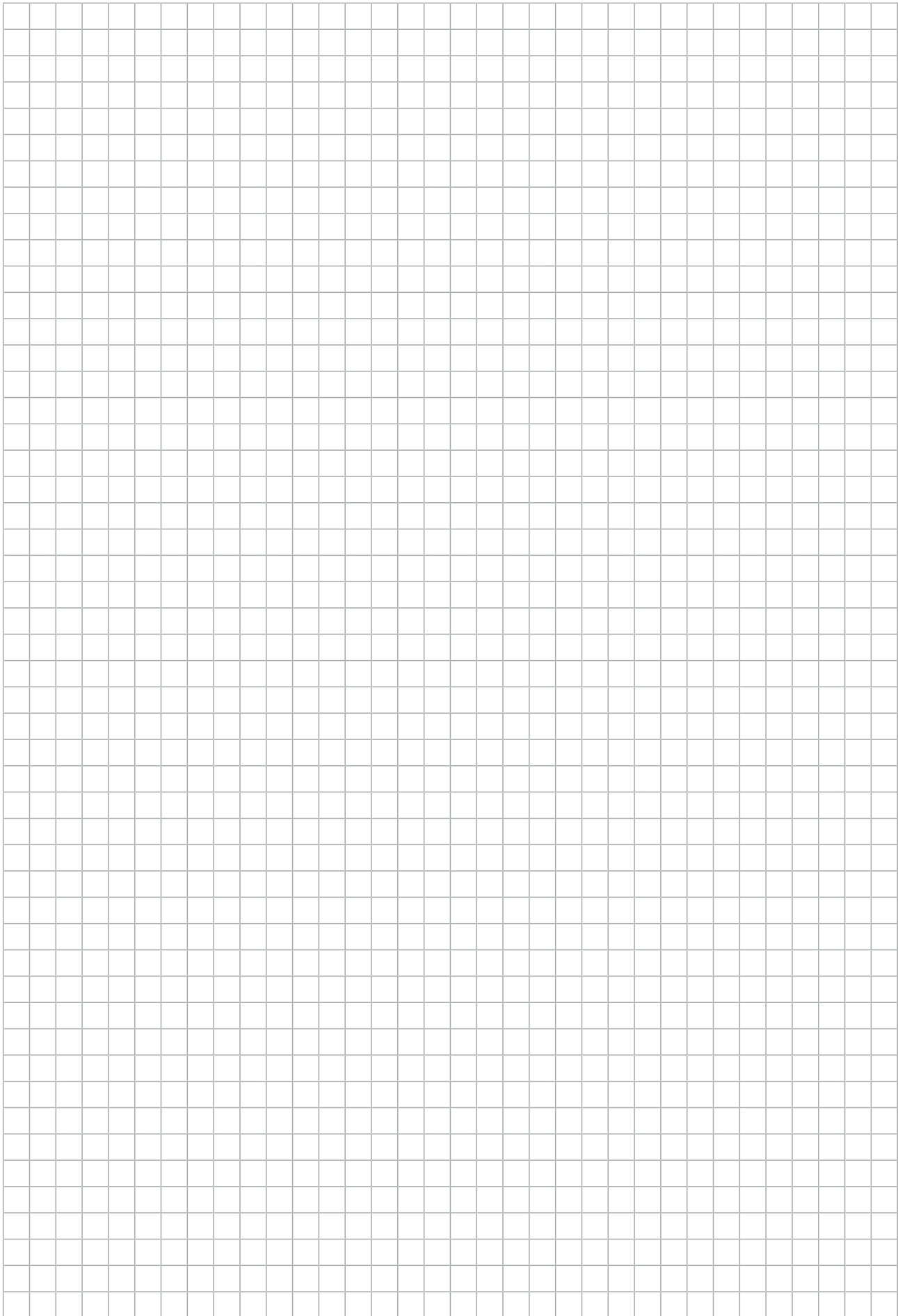

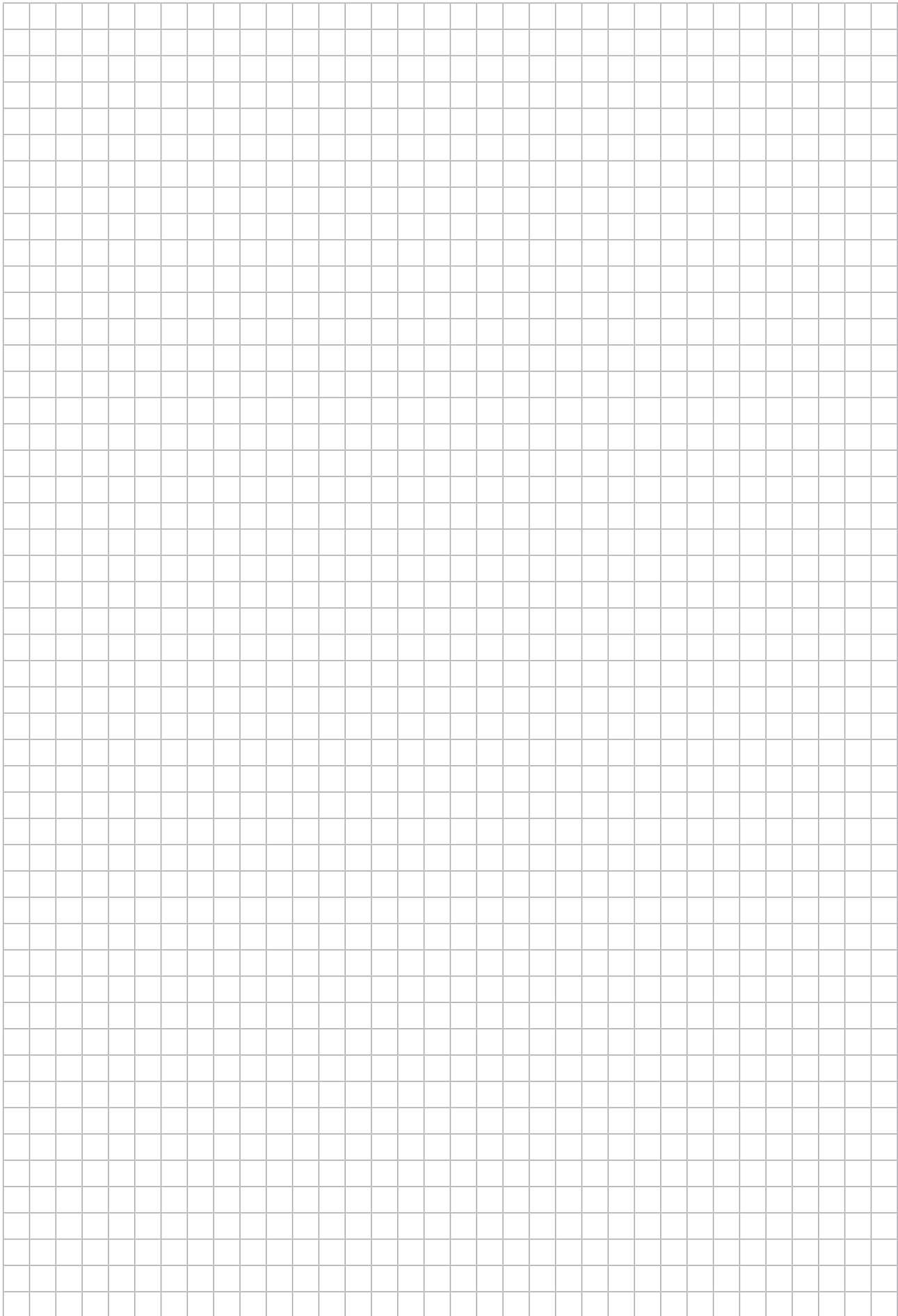

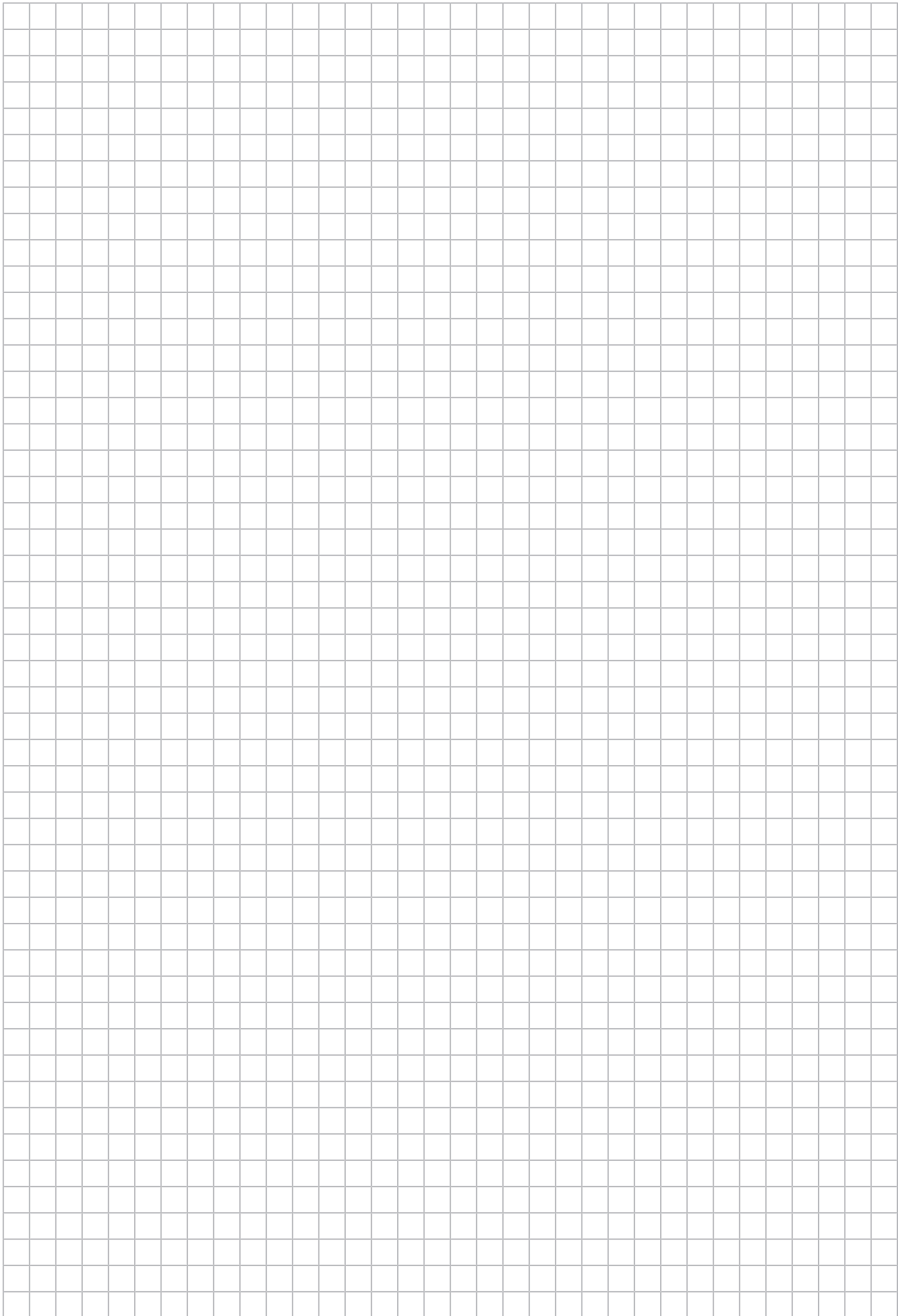





SEW-EURODRIVE
Driving the world

SEW
EURODRIVE

SEW-EURODRIVE GmbH & Co KG
Ernst-Blickle-Str. 42
76646 BRUCHSAL
GERMANY

Tel. +49 7251 75-0

Fax +49 7251 75-1970

sew@sew-eurodrive.com

→ www.sew-eurodrive.com