

# Svendborg Storm Brakes



# Svendborg Brakes

Since 1989, Svendborg Brakes has been recognized as a leading global expert in intelligent braking solutions for industrial applications. Extensive application knowledge, innovative design, fast prototyping and exhaustive testing ensures that customers get the most technically advanced, most durable and safest braking systems to meet their specific requirements.

Svendborg offers a wide range of highly engineered products including hydraulic brakes and power units, thruster brakes, soft braking controls and couplings. Svendborg braking solutions are hard at work in key markets including renewable energy, mining, hydropower, cranes and oil & gas, mining, and marine & offshore on applications such as wind and tidal turbines, overland conveyors, propulsion systems, deck equipment, hoists, drawworks, elevators & escalators and dam turbines.

VISIT US ON THE WEB AT [SVENDBORG-BRAKES.COM](http://SVENDBORG-BRAKES.COM)



# Altra Motion

Altra is a leading global designer and producer of a wide range of electromechanical power transmission and motion control components and systems. Providing the essential control of equipment speed, torque, positioning, and other functions, Altra products can be used in nearly any machine, process or application involving motion. From engine braking systems for heavy duty trucks to precision motors embedded in medical robots to brakes used on offshore wind turbines, Altra has been serving customers around the world for decades.

Altra's leading brands include **Ameridrives**, **Bauer** Gear Motor, **Bibby** Turboflex, **Boston** Gear, **Delevan**, **Delroyd** Worm Gear, **Formsprag** Clutch, **Guardian** Couplings, **Huco**, **Jacobs** Vehicle Systems, **Kilian**, **Kollmorgen**, **Lamiflex** Couplings, **Marland** Clutch, **Matrix**, **Nuttall** Gear, **Portescap**, **Stieber**, **Stromag**, **Svendborg** Brakes, **TB Wood's**, **Thomson**, **Twiflex**, **Warner** Electric and **Wichita** Clutch.

VISIT US ON THE WEB AT [ALTRAMOTION.COM](http://ALTRAMOTION.COM)



## CONTENT

---

<b>GRBS RAIL BRAKES</b>	<b>4</b>
<b>LRBS RAIL BRAKES</b>	<b>6</b>
<b>RRBS RETRACTABLE RAIL BRAKES</b>	<b>8</b>
<b>RPS RAIL PRESS BRAKES</b>	<b>10</b>
<b>RPS-SA RAIL BRAKES - SELF ADJUSTING</b>	<b>12</b>
<b>WBES WHEEL BRAKES ELECTRICAL</b>	<b>14</b>
<b>WBHS WHEEL BRAKES HYDRAULIC</b>	<b>16</b>

## Storm Brakes

# GRBS RAIL BRAKES



**GRBS Rail Brakes, fitted with hardened steel guides, can accommodate rail with large vertical fluctuations.**

GRBS rail brakes are designed to apply friction forces on both sides of a rail. They are spring set and hydraulically or electrically released.

They ride above the rail with two flangeless rollers which continuously make contact with the rail. Hardened guides, attached to the cylindrical roller frame, protect serrated shoes from hitting the rail. As the clamp mechanism can float laterally with very little friction, guides wear is very low. This increases rail brakes safety and reliability and reduces the maintenance costs.

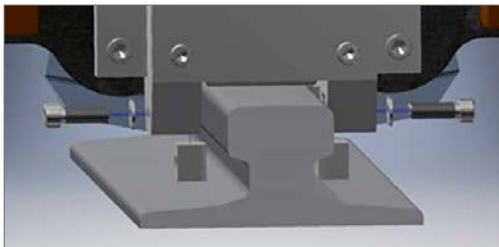

### Applications

- Ship to shore cranes
- Automated stacking cranes
- Wide span cranes
- Ship loaders
- Stacker Reclaimers
- Tripper cars

### Benefits

- Rail Clamp mechanism weight is distributed to two hardened, low friction flangeless Cylindrical Rollers.
- Top mounted hydraulic cylinder with no rod connection, easily removable for quick maintenance and replacement
- Serrated shoes protected from hitting the rail sides; limited wear and tear to guide means, brake shoes as well as rail head itself
- No need for lubrication points for the floating mechanism
- Simple design eliminates expensive replacement of profiled guide wheels with worn-out flanges
- Floating mechanism allowing compensation of **horizontal  $\pm 25\text{mm}$  and vertical  $\pm 25\text{mm}$  rail deviation** (more available upon request)
- Clamp release and reserve stroke monitoring by proximity switches
- Increased rail clamp safety and reliability while reducing maintenance costs



### TECHNICAL DATA

- SF Side Flange mount to the crane structure
- TF Top Flange mount available (50 to 600 kN)
- Stainless steel removable cover with inspection doors
- Caging bolts for mechanical release
- Min Paint Thickness: 200-275  $\mu\text{m}$
- Prewired junction box
- Hand pump for manual release
- Solenoid valve with manual override
- Solenoid coil with LED indicator
- Integrated Temperature/Level Switch
- Adjustable setting time from 2-30 seconds

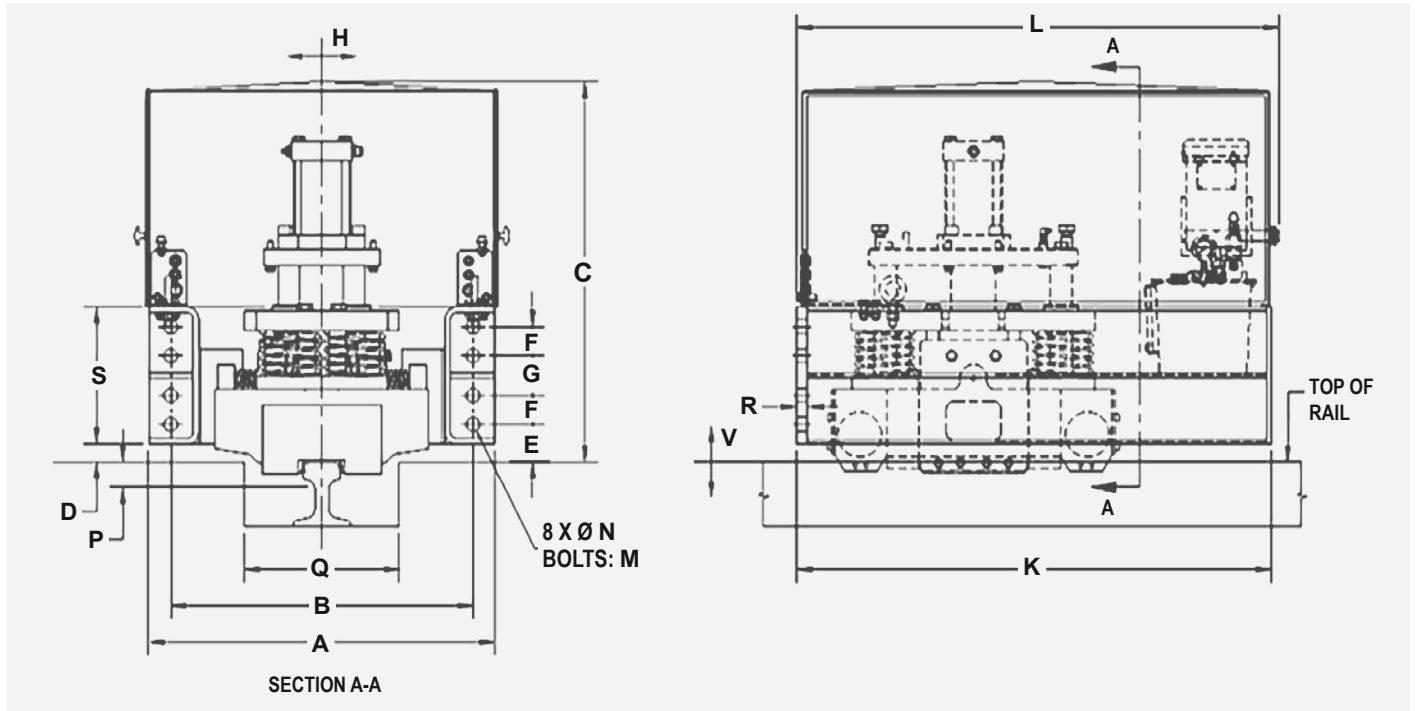

V Vertical Rail Deviation (Float)  $\pm 25\text{mm}$  relative to Rail Clamp enclosure at full rated capacity.  
 H Horizontal Rail Position Deviation (Float)  $\pm 25\text{mm}$  relative to Rail Clamp enclosure at full rated capacity.  
 Q\* Dimensions are subject to a specific rail size.  
 Models with holding capacities calculated with friction factor 0.25 available upon request.

MODEL	HOLDING CAPACITY (kN)	A	B	C	D	E	F	G	K	L	M	N	P	Q*	R	S
GRBS-HS-50-SF	50	578	530	687	30	75	50	65	896	916	20	22	50	280	22	254
GRBS-HS-100-SF	100															
GRBS-HS-150-SF	150	705	635	775	40	85	65	90	885	909	27	29	50	340	32	310
GRBS-HS-200-SF	200															
GRBS-HS-250-SF	250															
GRBS-HS-300-SF	300															
GRBS-HS-350-SF	350	800	700	860	40	105	75	100	1200	1220	36	39	50	380	38	380
GRBS-HS-400-SF	400															
GRBS-HS-450-SF	450															
GRBS-HS-500-SF	500															
GRBS-HS-600-SF	600	850	730	1050	40	120	110	170	1200	1220	39	42	50	380	38	380
GRBS-HS-800-SF	800															
GRBS-HS-900-SF	900															
GRBS-HS-1000-SF	1000															

## Storm Brakes

### LRBS RAIL BRAKES



**LRBS Rail Brakes are guided by hardened steel guides along the rail. They are designed for cranes riding on a rail with minimum vertical fluctuations.**

LRBS rail brakes are designed to apply friction forces on both sides of a rail. They are spring set and hydraulically or electrically released.



#### Applications

- Ship to shore cranes
- Automated stacking cranes
- Wide span cranes
- Ship loaders
- Stacker Reclaimers
- Tripper cars

#### Benefits

- Rail Clamp mechanism guided along the rail with hardened steel guiding blocks
- Top mounted hydraulic cylinder with no rod connection, easily removable for quick maintenance and replacement
- Serrated shoes protected from hitting the rails sides by guiding blocks
- No need for lubrication points for the floating mechanism
- Simple design eliminates expensive replacement of profiled guide wheels with worn-out flanges
- Floating mechanism allowing compensation **of horizontal  $\pm 25\text{mm}$  and vertical  $\pm 5\text{mm}$  rail deviation**
- Clamp release indication signal provided by proximity switch
- Simple mechanism with small number of moving parts for easy maintenance



### TECHNICAL DATA

- SF Side Flange mount to the crane structure
- TF Top Flange mount available
- Stainless steel cover
- Caging bolts for mechanical release
- Min Paint Thickness: 200-275 µm

- Prewired junction box
- Hand pump and/or caging bolts for manual release
- Low leakage solenoid valve
- Solenoid coil with LED indicator
- Adjustable setting time from 2-30 seconds

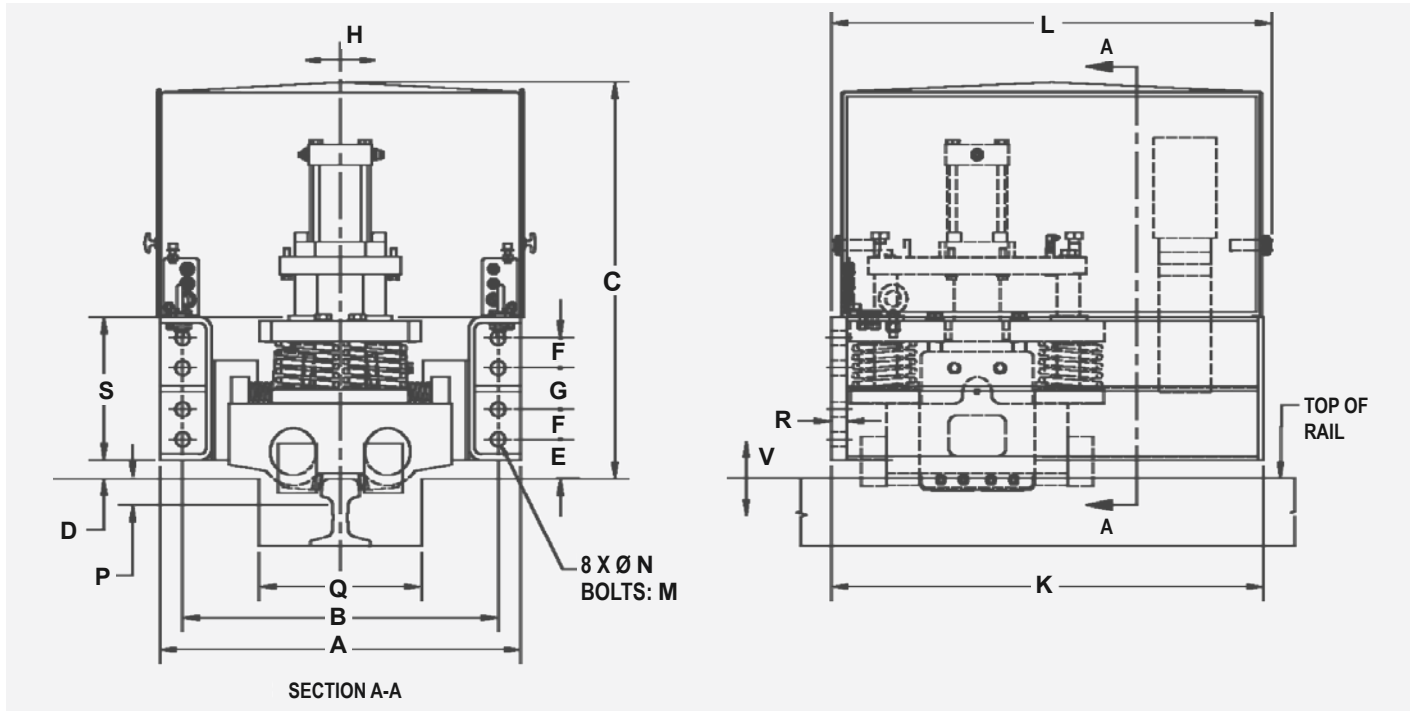

**V** Vertical Rail Deviation (Float)  $\pm 5$ mm relative to Rail Clamp enclosure at full rated capacity.

**H** Horizontal Rail Position Deviation (Float)  $\pm 25$ mm relative to Rail Clamp enclosure at full rated capacity. Larger floats available upon request.

**Q\*** Dimensions are subject to a specific rail size. **N\*\*** LRBS-50/100 series come with four holes bolt pattern.

Models with holding capacities calculated with friction factor 0.25 available upon request.

MODEL	HOLDING CAPACITY (kN)	A	B	C	D	E	F	G	K	L	M	N	P	Q*	R	S
LRBS-HS-50-SF	50	540	470	652	30	60	140	x	630	x	24	26	50	300	22	203
LRBS-HS-100-SF	100															
LRBS-HS-150-SF	150	705	635	770	40	85	65	90	860	885	27	29	50	350	32	310
LRBS-HS-200-SF	200															
LRBS-HS-250-SF	250															
LRBS-HS-350-SF	350															
LRBS-HS-400-SF	400	800	700	860	40	105	75	100	1200	1220	36	39	50	380	38	380
LRBS-HS-450-SF	450															
LRBS-HS-500-SF	500															
LRBS-HS-600-SF	600															
LRBS-HS-650-SF	650															

## Storm Brakes

# RRBS RETRACTABLE RAIL BRAKES



## RRBS Retractable Rail Brakes are the obvious choice especially for modern high speeds cranes

RRBS rail brakes are designed to clamp on both sides of a rail. They are spring set and hydraulically or electrically released. They are designed to release and retract fully above the rail head. This eliminates mechanical guiding means at rail level. So there is no wear and tear to guide means, brake shoes or the rails head itself. The RRBS rail clamp mechanism is top supported and float laterally with ease. All the features of these brakes allow reliability and low maintenance.

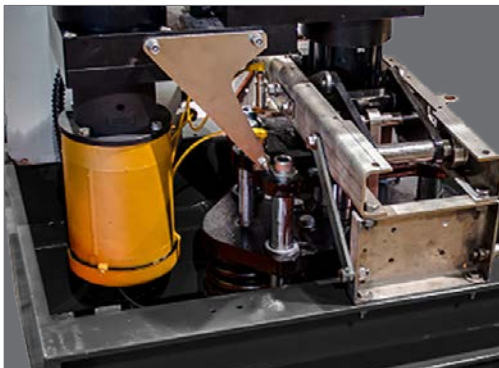

### Applications

- Ship to shore cranes
- Automated stacking cranes
- Wide span cranes
- Ship loaders
- Rail-mounted material handling equipment

### Benefits

- Simple single cylinder solution that lifts all the critical components completely free of the rail
- Serrated shoes protected from hitting the rail sides, no wear and tear to guide means, brake shoes as well as rail head itself
- No need for lubrication points for the floating mechanism
- The effect of the vibrations on the rail clamp mechanism during crane travel is minimized
- Floating mechanism allowing compensation of **horizontal  $\pm 25\text{mm}$  and vertical  $\pm 25\text{mm}$  rail deviation** (more available upon request)
- Top mounted hydraulic cylinder with no rod connection, easily removable for quick maintenance and replacement
- Clamp release, positioning and reserve stroke monitoring by proximity switches
- Increased reliability and safety while lowering maintenance costs





### TECHNICAL DATA

- SF Side Flange mount to the crane structure
- TF Top Flange mount available (50 to 600 kN)
- Stainless steel removable cover with inspection doors
- Caging bolts for mechanical release
- Min Paint Thickness: 200-275  $\mu\text{m}$
- Prewired junction box
- Hand pump for manual release
- Solenoid valve with manual override
- Solenoid coil with LED indicator
- Integrated Temperature/Level Switch
- Adjustable setting time from 2-30 seconds

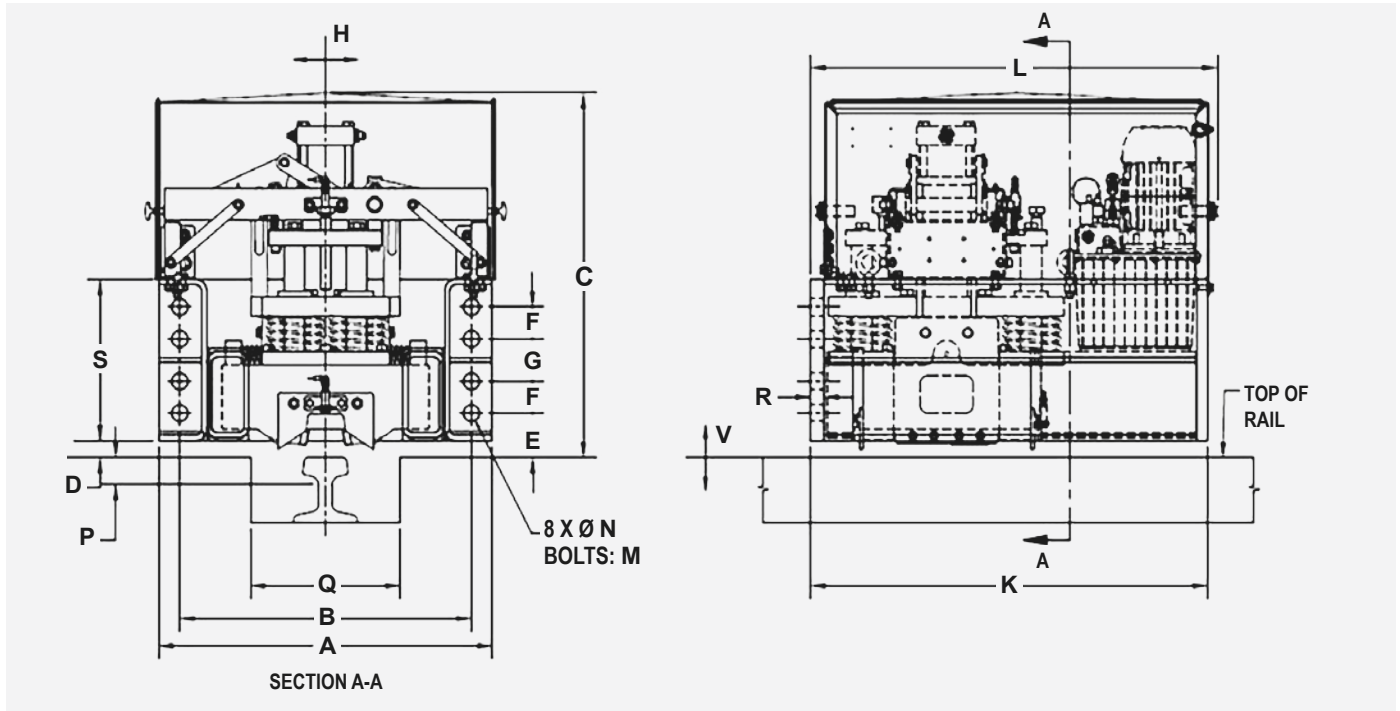

**1V** Vertical Rail Deviation (Float)  $\pm 25\text{mm}$  relative to Rail Clamp enclosure at full rated capacity.

**2H** Horizontal Rail Position Deviation (Float)  $\pm 25\text{mm}$  relative to Rail Clamp enclosure at full rated capacity. Larger floats available upon request.

**Q\*** Dimensions are subject to a specific rail size.

MODEL	HOLDING CAPACITY (kN)	A	B	C	D	E	F	G	K	L	M	N	Q*	P	R	S
RRBS-HS-50-SF	50	578	530	735	30	75	50	65	710	735	20	22	280	70	22	254
RRBS-HS-100-SF	100															
RRBS-HS-150-SF	150															
RRBS-HS-200-SF	200	705	635	775	40	85	65	90	860	895	27	29	340	75	32	310
RRBS-HS-250-SF	250															
RRBS-HS-300-SF	300															
RRBS-HS-350-SF	350	800	700	860	40	105	75	100	950	976	36	39	380	75	38	380
RRBS-HS-400-SF	400															
RRBS-HS-450-SF	450															
RRBS-HS-500-SF	500	850	730	1050	40	120	110	170	1200	1230	39	42	380	75	38	380
RRBS-HS-600-SF	600															
RRBS-HS-800-SF	800															
RRBS-HS-900-SF	900	900	780	1050	40	115	100	180	1400	1430	42	45	400	75	45	530
RRBS-HS-1000-SF	1000															
RRBS-HS-1200-SF	1200															

## Storm Brakes

### RPS RAIL PRESS BRAKES



#### **RPS Rail Press Brakes apply spring force on the top of the rail while allowing a large rail vertical fluctuation**

RPS rail brakes use the weight of the crane in the braking process and provide the braking force along the rail.

They are spring set and hydraulically released. Once released, the brake hangs above the rail at a pre-designed clearance.

Actual braking capacity depends on the applied force and applicable coefficient of friction (different for static and dynamic braking).

RPS brakes are parking brakes designed to apply when a crane comes into a full stop position.



#### **Applications**

- Ship to Shore Cranes
- Automated Stacking Cranes
- Wide Span Cranes
- Rail Mounted Gantry Cranes
- Log Handling Cranes
- Ship loaders

#### **Benefits**

- Allows for large variations of the rail height by means of a longer spring stroke
- Provides a balanced braking force / stroke curve
- Serrated / Smooth shoes fully protected from hitting the top of the rail for less wear and tear
- Oversized longer lasting springs for reduced maintenance
- Flow control valve installed on the brake for controlled setting time
- Proximity switch for release indication
- Brake shoes easily removed and replaced
- Made with high quality structural steel
- Simple mechanism with small number of moving parts for easy maintenance



### TECHNICAL DATA

- Fabricated from high quality structural steel.
- Brake shoes easily removed and replaced
- Min Paint Thickness DFT: 200-275  $\mu$ m

Supplied with Hydraulic Power Unit:

- Prewired junction box
- Hand pump for manual release
- Solenoid valve with manual override
- Solenoid coil with LED indicator

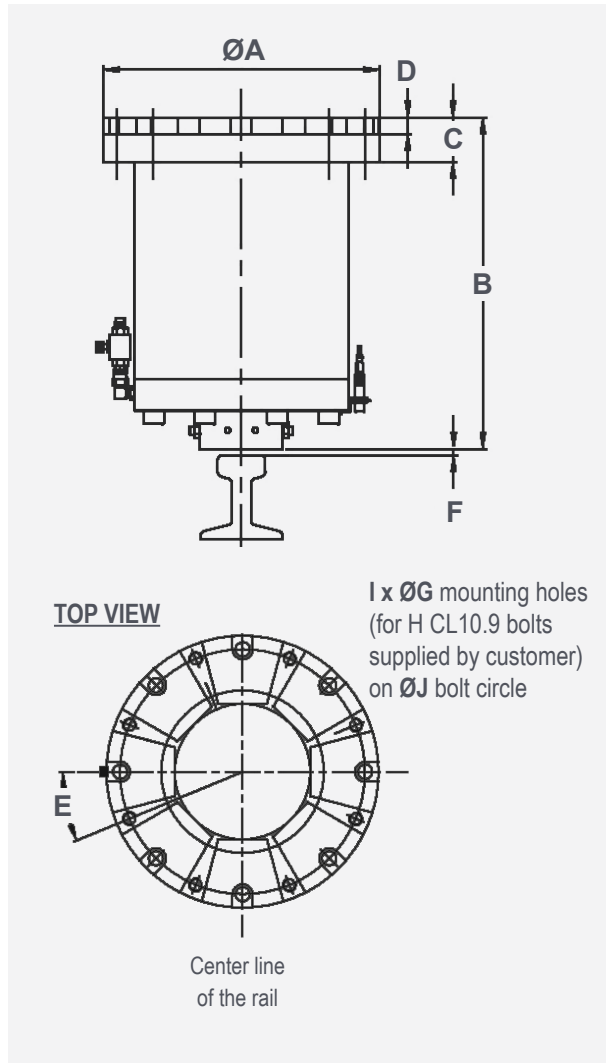

**SRPS-C** Static Rail Press - Spring set - Hydraulic release  
**DRPS-C** Dynamic Rail Press - Spring set - Hydraulic release with smooth shoes available

OPERATING SPECIFICATIONS SRPS-220-C			
	Shoe extension: <b>F</b> mm	Applied force kN	Braking force kN ( $\mu = 0.5$ )
<b>BRAKE RELEASED</b>	0	595	-
<b>BRAKE APPLIED</b>	8	517	258
	12	479	239
	16	440	220
	20	402	201

### NOMINAL SPECIFICATIONS SRPS-220-C

- Nominal braking force 220 kN @ shoe extension **F** and coefficient of friction  $\mu=0.5$
- Brake must be installed above the rail at a height of **B** mm + **F** (applicable piston rod extension) +/-2mm
- Static series **S** of rail brakes must be used for static braking (crane at stop position)

MODEL	HOLDING CAPACITY (kN)	A	B	C	D	E	F	G	H	J	I
<b>SRPS-130-C</b>	130	508	578	83	31	30	16	27	M24	457	8
<b>SRPS-220-C</b>	220	508	610	83	31	22.5	16	27	M24	457	8
<b>SRPS-300-C</b>	300	572	752	89	35	15	16	32	M30	478	12

Static models braking capacities calculated with coefficient of friction factor 0.5

## Storm Brakes

# RPS-SA RAIL BRAKES - SELF ADJUSTING



**RPS-SA Rail Brakes compensate an extra large  $\pm 19\text{mm}$  rail vertical fluctuation, they are automatically adjusted before braking**

RPS-SA brakes apply spring force on the top of the rail, they use the weight of the crane in the braking process and provide the friction force along the rail. Two step braking ensures that the shoe is in contact with the rail before spring force is applied.

They are spring set and hydraulically or electrically released. Once released, the brake hangs above the rail at a pre-designed clearance. Actual braking capacity depends on the applied force and applicable coefficient of friction (different for static and dynamic braking).



### Applications

- Ship to Shore Cranes
- Rail Mounted Gantry Cranes
- Automated Stacking Cranes
- Log Handling Cranes
- Wide Span Cranes
- Ship loaders

### Benefits

- Completely spring-set rail brake
- Allows up to **38mm rail vertical fluctuation** while providing uniform rated capacity over the full range of movement
- Consistent spring stroke for longer spring life
- Serrated / Smooth shoes fully protected from hitting the top of the rail for less wear and tear
- All components, including the hydraulic release cylinder are fully enclosed in a sealed housing, out of the elements
- Flow control valve installed on the brake for controlled setting time
- Proximity switch for release indication signal
- Brake shoes easily removed and replaced
- Made with high quality structural steel
- Compact design fits most existing locations, even those with drop pins. Low height allows retrofitting with adapter flanges.



### TECHNICAL DATA

- Springs application
- Hydraulic release
- Proximity switch for release monitoring

Supplied with Hydraulic Power Unit:

- Prewired junction box
- Hand pump for manual release
- Solenoid valve with manual override
- Solenoid coil with LED indicator

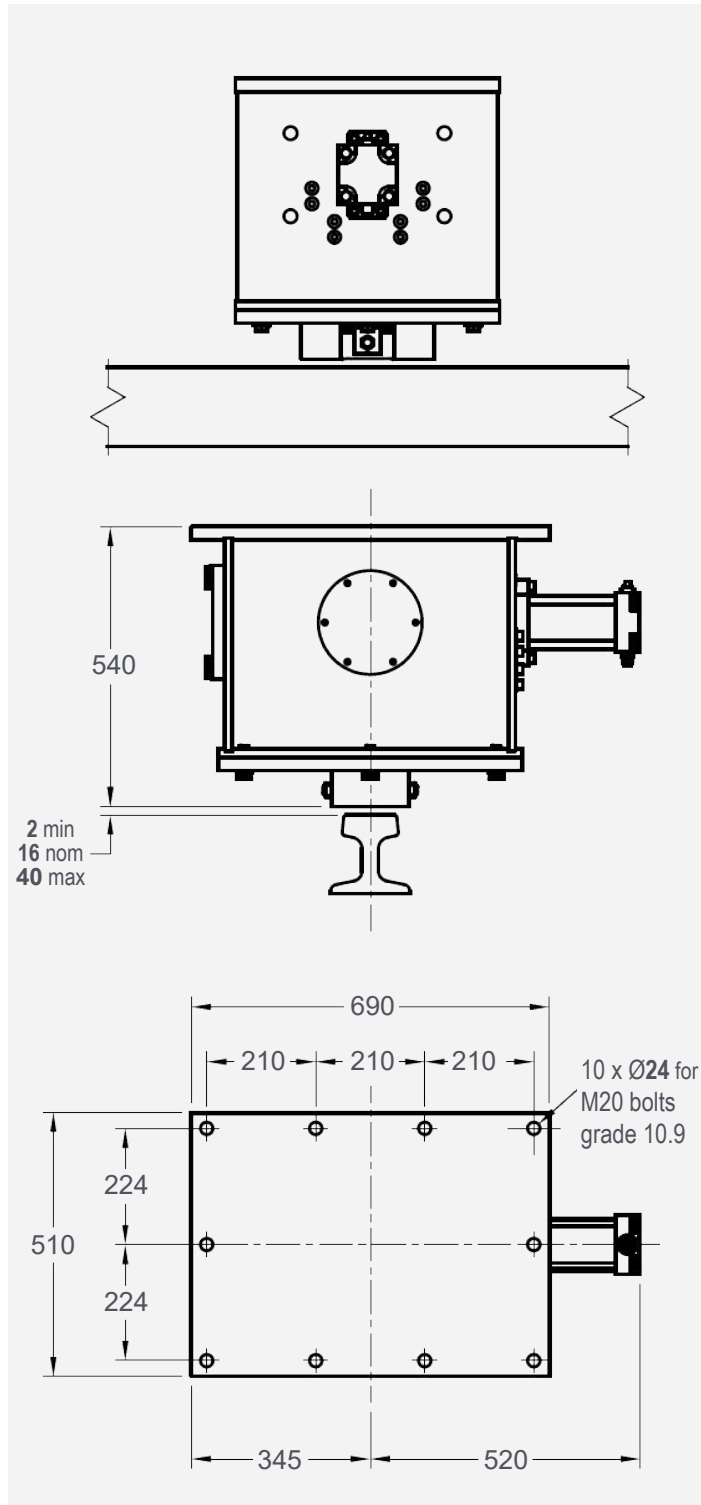

- **SRPS-SA** Static rail brake: 150 kN & 220 kN
- **DRPS-SA** Dynamic rail brake: 120 kN & 180 kN  
Hydraulic release with smooth shoes available
- **RPS-E-SA** Rail brake with electric release

### RPS-SA-220 Braking force at various stroke extensions

	Shoe extension: E mm	Applied force kN	Braking force kN ( $\mu=0.5$ )
<b>BRAKE RELEASED</b>	0	470	235
<b>BRAKE APPLIED</b>	2	450	225
	8	445	222
	16	440	220
	28	420	210
	40	410	205

### NOMINAL SPECIFICATIONS SRPS-220-SA

- Nominal braking force 220 kN @ shoe extension **F** and coefficient of friction  $\mu=0.5$
- Brake must be installed above the rail at a height of 540mm + **A** (applicable piston rod extension) +/-2mm
- Static series **S** of rail brakes must be used for static braking (crane at stop position)

# WBES WHEEL BRAKES ELECTRICAL



## WBES Wheel Brakes are parking and safety devices that can be used as dynamic brakes in case of emergency

**WBES** Wheel Brakes apply force generated by springs on both sides of the crane wheels. Oversized brake shoes with bonded friction material apply on the side flanges of idler wheels, providing the friction forces, and thus, braking capacity.

Designed as parking brakes to be applied when equipment comes to a full stop, **WBES** wheel brakes can be also used as dynamic brakes in an emergency situation. By applying spring force directly on the wheel flanges, they minimize the amount of stress and strain otherwise placed on sill beams and truck assemblies of a crane.

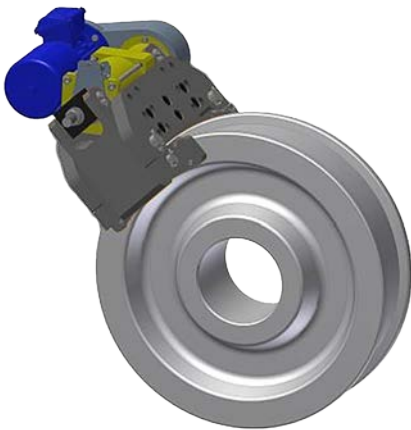

### Applications

- Ship to Shore Cranes
- Automated Stacking Cranes
- Wide Span Cranes
- Rail Mounted Gantry Cranes
- Log Handling Cranes
- Ship loaders

### Benefits

- Spring Set – patented fully Electric Release
- No hydraulic components, so no environmental or fire liabilities
- High efficiency actuator for spring applied braking devices utilize an electromechanical release and hold system
- Actuator holding brake in sealed enclosure and with low power consumption, keeps wheel brake pads released until power is cut-off or lost
- Setting time can be adjusted by a mechanical regulator for setting time delay from 3 to 30 seconds
- The regulator does not use friction and is free from wear
- Brake release monitored by proximity switch
- Equipped with shoe alignment device
- Maximum pad wear is 6mm per side

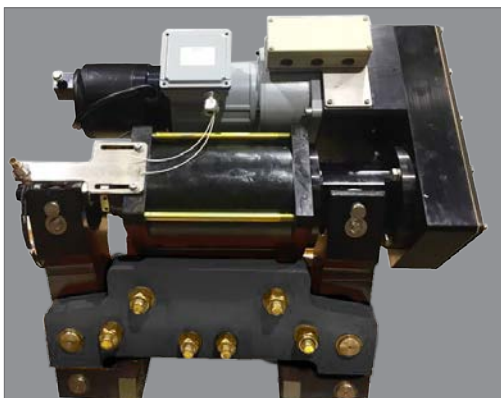

### TECHNICAL DATA

- Fabricated from high quality structural steel.
- Brake shoes easily removed and replaced
- Min Paint Thickness DFT: 200-275  $\mu\text{m}$

Supplied with linear actuator:

- High efficiency actuators
- Supplied with release nut for mechanical brake release
- Electric drive components easily accessible and removable
- Electric actuator drive easy to understand and service

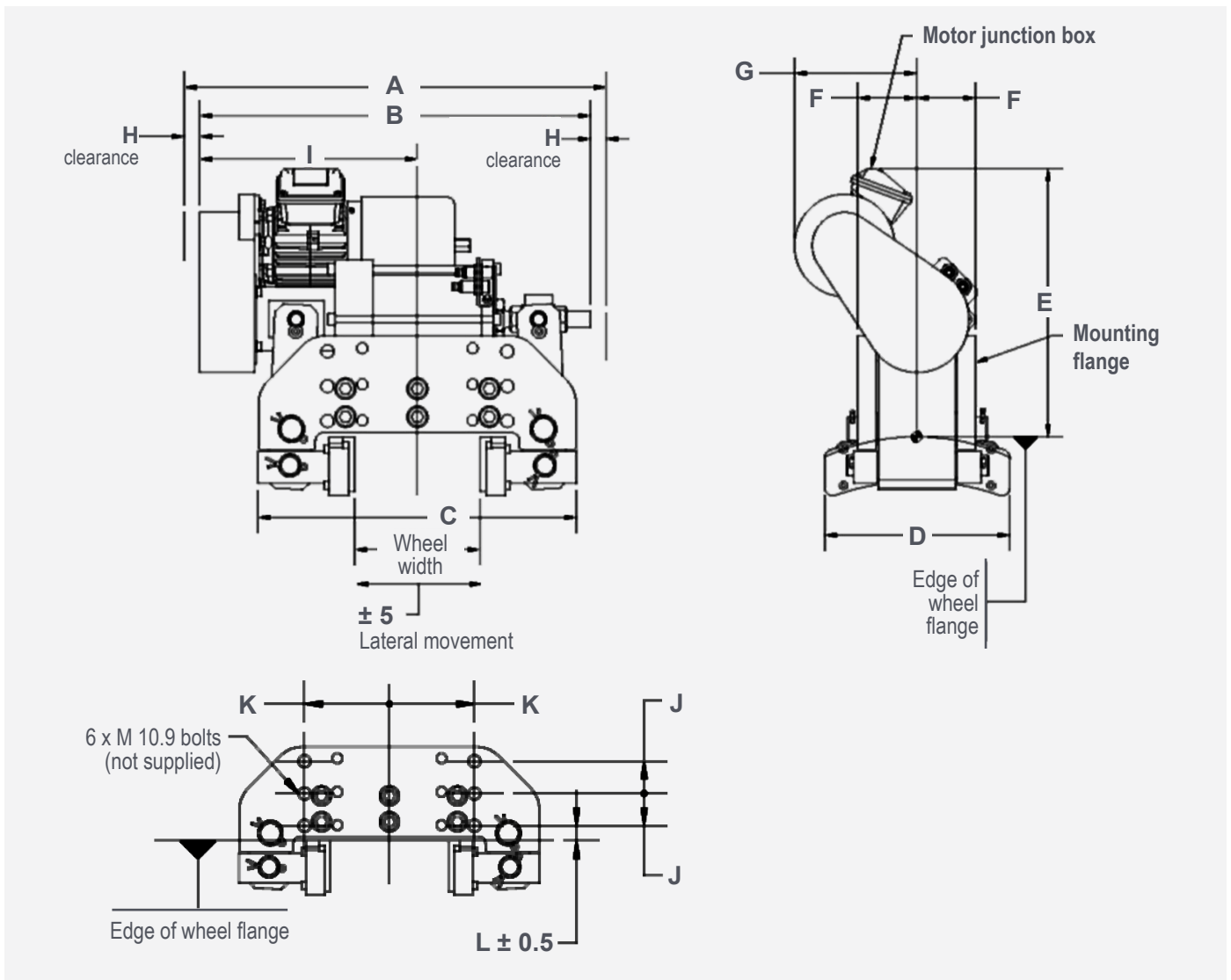

MODEL	HOLDING CAPACITY (kN)	A	B	C	D	E	F	G	H	I	J	K	L	M
WBES-30-A	50	735	675	500	315	475	75	250	30	380	50	125	25	M20
WBES-30-B											57	89	26	M20
WBES-60-A	60	735	675	500	315	475	75	250	30	380	50	125	25	M20
WBES-60-B											57	89	26	M20
WBES-90-A	90	735	675	550	315	508	110	250	30	361	55	145	30	M24
WBES-90-B											57	89	26	M20
WBES-120-A	120	735	675	550	315	508	110	250	30	361	55	145	30	M24
WBES-120-B											57	89	26	M20

## Storm Brakes

# WBHS WHEEL BRAKES HYDRAULIC

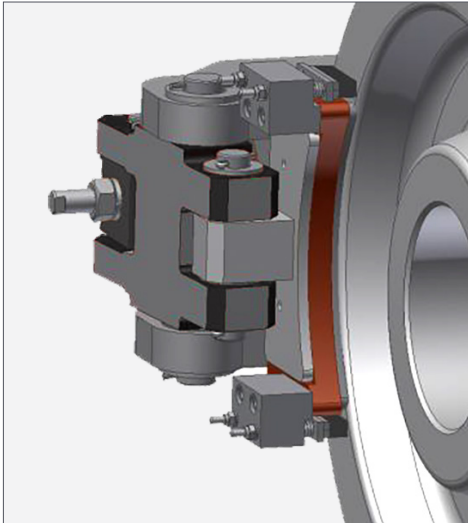

## WBHS Wheel Brakes are parking and safety devices that can be used as dynamic brakes in case of emergency

**WBHS** Wheel Brakes apply force generated by springs on both sides of the crane wheels. Oversized brake shoes with bonded friction material apply on the side flanges of idler wheels, providing the friction forces, and thus, braking capacity.

Designed as parking brakes to be applied when equipment comes to a full stop, **WBHS** wheel brakes can be also used as dynamic brakes in an emergency situation. By applying spring force directly on the wheel flanges, they minimize the amount of stress and strain otherwise placed on sill beams and truck assemblies of a crane.



### Applications

- Ship to Shore Cranes
- Automated Stacking Cranes
- Wide Span Cranes
- Rail Mounted Gantry Cranes
- Log Handling Cranes
- Ship loaders

### Benefits

- Spring Set – Hydraulic Release
- Flow control valve installed on the brake for the controlled setting time 3 to 30 seconds
- Self-lubricating bushings and stainless steel pins on all pivot points
- Proximity switch for release indication signal
- Brake shoes easily removed and replaced
- Made with high quality structural steel
- Nominal retracted clearance 1mm per side. Recommended maximum clearance 2mm per side
- Equipped with shoe alignment device
- Supplied with release nut for mechanical brake release
- Operated and released by Hydraulic Power Unit HPU

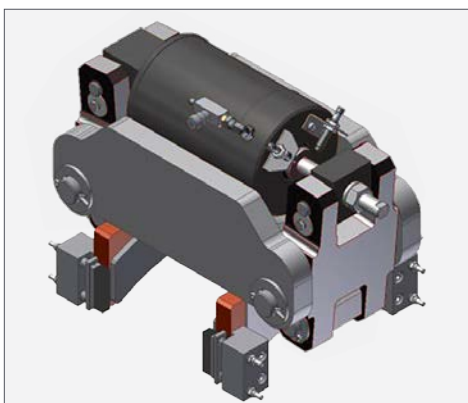



### TECHNICAL DATA

- Fabricated from high quality structural steel.
- Brake shoes easily removed and replaced
- Min Paint Thickness DFT: 200-275  $\mu\text{m}$

#### Supplied with Hydraulic Power Unit:

- Prewired junction box
- Hand pump for manual release
- Solenoid valve with manual override
- Solenoid coil with LED indicator

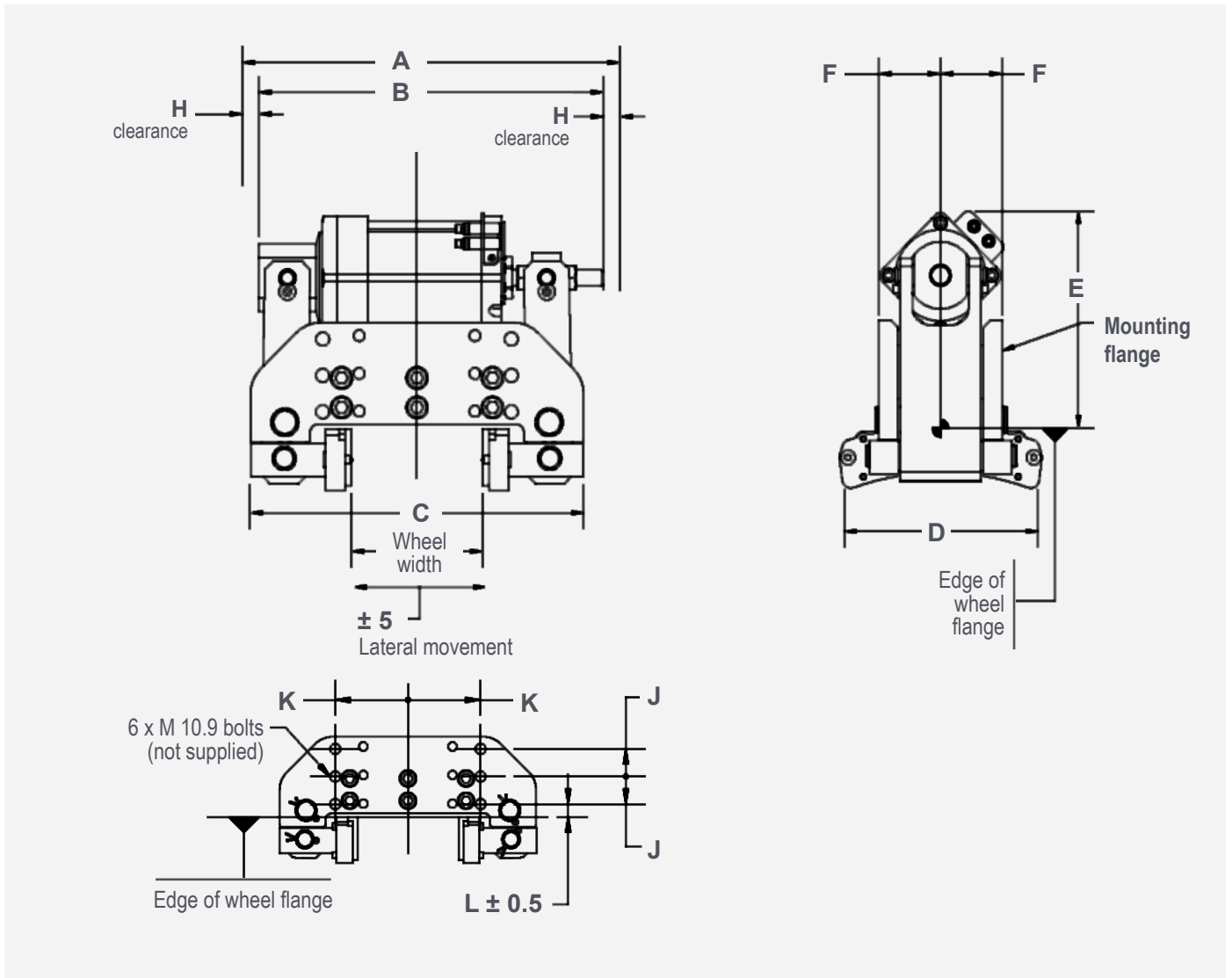

MODEL	HOLDING CAPACITY (kN)	A	B	C	D	E	F	H	J	K	L	M
WBHS-30-A	50	600	535	500	315	330	75	30	50	125	25	M20
WBHS-30-B									57	89	26	M20
WBHS-60-A	60	600	535	500	315	330	75	30	50	125	25	M20
WBHS-60-B									57	89	26	M20
WBHS-90-A	90	600	535	550	315	330	110	30	55	145	30	M24
WBHS-90-B									57	89	26	M20
WBHS-120-A	120	600	535	550	315	330	110	30	55	145	30	M24
WBHS-120-B									57	89	26	M20



# Premier Industrial Company Leading Brands

## OTHER PRODUCT SOLUTIONS FROM **ALTRA MOTION**

Our comprehensive product offerings include various types of clutches and brakes, overrunning clutches, engineered bearing assemblies, gearing and gear motors along with linear motion products, belted drives, couplings, limit switches, precision motors, drives & controls, miniature motors and engine braking systems. With thousands of product solutions available, Altra provides true single source convenience while meeting specific customer requirements. Many major OEMs and end users prefer Altra products as their No. 1 choice for performance and reliability.

**WWW.ALTRAMOTION.COM**



### **Electric Clutches & Brakes**

Inertia Dynamics  
Matrix  
Stromag  
Warner Electric



### **Precision Motors & Automation**

Kollmorgen



### **Heavy Duty Clutches & Brakes**

Industrial Clutch  
Stromag  
Svendborg Brakes  
Twiflex  
Wichita Clutch



### **Miniature Motors**

Portescap



### **Overrunning Clutches**

Formsprag Clutch  
Marland Clutch  
Stieber



### **Linear Systems**

Thomson



### **Engineered Couplings & Universal Joints**

Ameridrives  
Bibby Turboflex  
Guardian Couplings  
Huco  
Lamiflex Couplings  
Stromag  
TB Wood's



### **Engine Braking Systems**

Jacobs Vehicle Systems



### **Gear Drives & Gear Motors**

Bauer Gear Motor  
Boston Gear  
Delroyd Worm Gear  
Nuttall Gear



### **Specialty Components**

Kilian  
Stromag  
TB Wood's

## Svendborg Brakes Facilities

### Europe

Jernbanevej 9  
DK-5882 Vejstrup - Denmark  
+45 63 255 255  
sb@svendborg-brakes.com  
*Industrial Brakes and  
Brake Systems*

### Global Representations

**Australia**  
Perth  
+61 (0) 8 94 160300  
sales@altramotion.com.au

Newcastle  
+61 (0) 8 94 160300  
sales@altramotion.com.au

Brisbane  
+61 (0) 8 94 160300  
sales@altramotion.com.au

**Brazil**  
+55 11 4615-6300 /  
+55 11 5679-6553  
altra.vendas@altramotion.com

**Chile**  
Coquimbo  
+56 23 203 9150  
sa@svendborg-brakes.com

Santiago  
+56 23 203 9150  
sa@svendborg-brakes.com

**China**  
+86 21 60580600  
sb@svendborg-brakes.com

**Czech Republic**  
+420 2 51 68 01 68  
jan.mikyska@svendborg-brakes.com

**Denmark**  
+45 63 255 255  
sb@svendborg-brakes.com

**Germany**  
+49 5422 9272 000  
sb@svendborg-brakes.com

**India**  
+91 83909 97970  
milind.sule@altramotion.com

**Korea**  
+82 10 9703 0979  
jong.lee@svendborg-brakes.com

**Perú**  
+51 959 224488 /  
+51 959 223653  
pe@svendborg-brakes.com

**Poland**  
+48 605 765 904  
biuro@vitech.pl

**South Africa**  
+27 83 382 2479  
sbsales@sintech.co.za

**Spain**  
+34 (975) 2336 55  
sb@svendborg-brakes.com

**USA**  
+1 (303) 285 1271  
na@svendborg-brakes.com

## The Brands of Altra Motion

### Couplings

**Ameridrives**  
www.ameridrives.com

**Bibby Turboflex**  
www.bibbyturboflex.com

**Guardian Couplings**  
www.guardiancouplings.com

**Huco**  
www.huco.com

**Lamiflex Couplings**  
www.lamiflexcouplings.com

**Stromag**  
www.stromag.com

**TB Wood's**  
www.tbwoods.com

### Linear Systems

**Thomson**  
www.thomsonlinear.com

### Geared Cam Limit Switches

**Stromag**  
www.stromag.com

### Engineered Bearing Assemblies

**Kilian**  
www.kilianbearings.com

### Electric Clutches & Brakes

**Matrix**  
www.matrix-international.com

**Stromag**  
www.stromag.com

**Warner Electric**  
www.warnerelectric.com

### Belted Drives

**TB Wood's**  
www.tbwoods.com

### Heavy Duty Clutches & Brakes

**Twiflex**  
www.twiflex.com

**Stromag**  
www.stromag.com

**Svendborg Brakes**  
www.svendborg-brakes.com

**Wichita Clutch**  
www.wichitaclutch.com

### Gearing & Specialty Components

**Bauer Gear Motor**  
www.bauergears.com

**Boston Gear**  
www.bostongear.com

**Delevan**  
www.delevan.com

**Delroyd Worm Gear**  
www.delroyd.com

**Nuttall Gear**  
www.nuttallgear.com

### Engine Braking Systems

**Jacobs Vehicle Systems**  
www.jacobsvehiclesystems.com

### Precision Motors & Automation

**Kollmorgen**  
www.kollmorgen.com

### Miniature Motors

**Portescap**  
www.portescap.com

### Overrunning Clutches

**Formsprag Clutch**  
www.formsprag.com

**Marland Clutch**  
www.marland.com

**Stieber**  
www.stieberclutch.com

Neither the accuracy nor completeness of the information contained in this publication is guaranteed by the company and may be subject to change in its sole discretion. The operating and performance characteristics of these products may vary depending on the application, installation, operating conditions and environmental factors. The company's terms and conditions of sale can be viewed at <http://www.altramotion.com/terms-and-conditions/sales-terms-and-conditions>. These terms and conditions apply to any person who may buy, acquire or use a product referred to herein, including any person who buys from a licensed distributor of these branded products.

©2021 by Svendborg Brakes LLC. All rights reserved. All trademarks in this publication are the sole and exclusive property of Svendborg Brakes LLC or one of its affiliated companies.