



U.S. Tsubaki, Inc.

Power Transmission Components Division

Roller Chain Couplings



- Connect quickly and easily
- Handle high torque
- Keep your profits turning

Roller Chain Couplings

The Quality Connection

Roller Chain Couplings from U.S. Tsubaki are your connection to better profits and productivity. We've combined the best in the business — high-quality Roller Chain with a pair of specially cut, hardened-tooth Sprockets — to create a powerful, flexible coupling that keeps your operation running at peak performance.

For clean areas and light loads, choose our Nylon Chain Couplings. Assembled couplings are also available upon request.

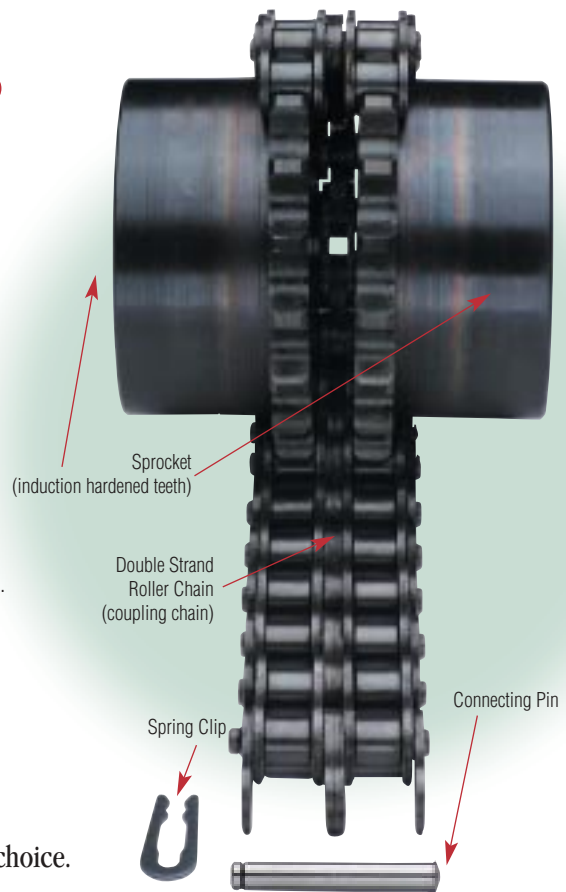

Make the Connection

Farming... mining... metal manufacturing...and more. When you need to connect two shafts, Roller Chain Couplings from U.S. Tsubaki are the right choice.

You can't make a better match!



- **Simple to Install**

Save valuable production time by getting your lines up and running fast. Simple construction makes our units easy to install, remove, and replace. Our unique, single-pin connection of the chain keeps downtime — and hassles — to a minimum. One clip is all it takes!

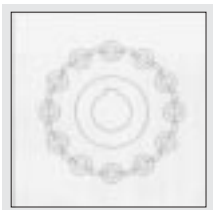

- **Compact and Powerful**

Remarkably efficient construction transmits torque easily by apportioning it over the entire strand of roller chain and all the sprocket teeth. You get the power you need to drive your business at an economical unit price.

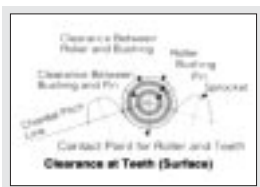

- **Flexible for Easy Alignment**

Clearances within the chain itself and between the chain and the sprocket teeth make our Roller Chain Couplings flexible and responsive. They align quickly and accurately and protect against overheating and abrasion caused by expansion or contraction of the shaft. You save time and money on adjustments and repairs.

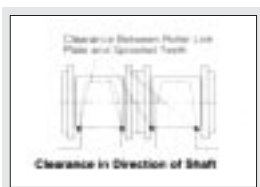

- **Built to Last**

Get the only flexible coupling on the market built to the quality standards of U.S. Tsubaki. Special double-strand roller chain with single-pin connector. Precision hardened sprockets with our standard dual set screw locking arrangement. The durability you need to handle high speed and torque, keeping maintenance and replacement costs low.

Coupling Covers Add Safety and Efficiency

Coupling Covers improve the safety, cleanliness, and overall performance of your system. Safe and smart, they protect the unit from outside elements and provide better workplace operation.

- Split-type construction provides easy installation and inspection.
- Continuous lubrication keeps lines running smoothly with minimum maintenance, extending service life.
- Smooth-surface design covers entire unit with no projecting bolts, providing a neat appearance and safe operation.

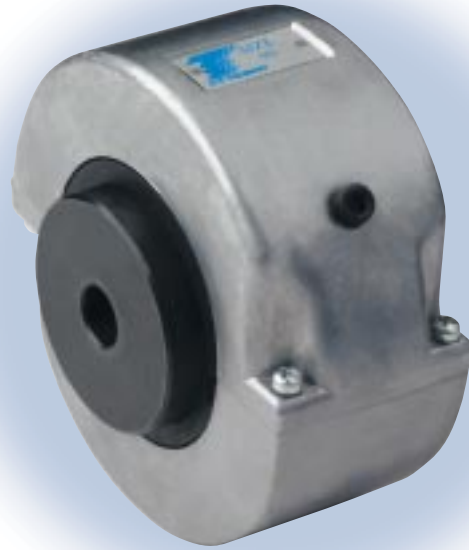

Reduce Your Hassles with a Single, Reliable Source

Partner with U.S. Tsubaki for savings and convenience. You benefit from the power of one:

- One call to get the highest quality power transmission products available
- One order to track
- One delivery to handle
- One invoice to process

Time is money. Reduce your processing time and increase your profits with a single call to U.S. Tsubaki.

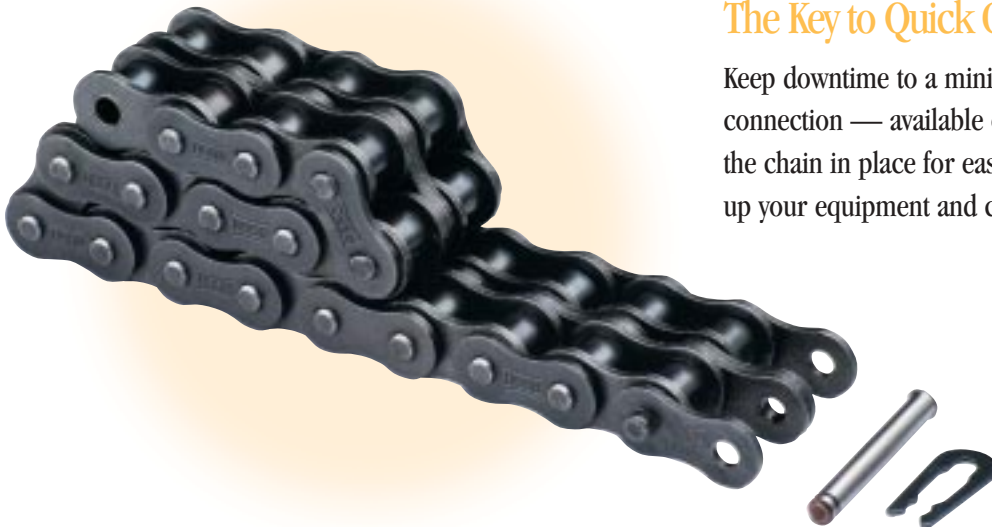

The Key to Quick Connections

Keep downtime to a minimum with our unique single-pin connection — available only from U.S. Tsubaki. A single pin holds the chain in place for easy installation. You spend less time setting up your equipment and can quickly get production rolling.

Selection Guidelines

Required Information

1. Number of hours of daily operation
2. Classification of load and prime mover
3. Horsepower or required torque to be transmitted and shaft speed in revolutions/minute
4. Diameter of both shafts



Method for Selection

1. Based on the operating conditions, determine the Service Factor, using Table 1.
2. Obtain the design horsepower by multiplying the horsepower to be transmitted by the Service Factor.
3. With the required rpm, choose the coupling that satisfies the horsepower from the Horsepower Rating, shown in Table 2.
4. When the required shaft diameter exceeds the maximum bore diameter of the coupling you have chosen, use a coupling that is one size larger.
5. In the low-speed range, the shearing pressure might be too great when using a standard key. In this case, calculate the key shearing pressure to determine if it is necessary to use a special key or spline bore.
6. Note the lubrication system required and select the coupling cover as necessary. In all applications, use of a coupling cover will provide quieter running, longer life, and safer operation.

Table 1. Service Factor

Load Classification	Source of Power		
	Electric motors or steam turbines	Reciprocating engines 4 or more cylinders	Reciprocating engines less than 4 cylinders
Uniform load, little shock, low starting torque, no reversing	1.0	1.5	2.0
Moderate fluctuation of load, moderate shock, no reversing (for most common applications)	1.5	2.0	2.5
Large fluctuations of load, heavy shock, reversal under load, full load starting	2.0	2.5	3.0

Note: Additional service factor for Roller Chain Coupling by operating hours (at 50 r/min and more)
 8 hours to 16 hours/day - 0.5
 16 hours or more/day - 1.0

Table 2. HP Rating Table

Cplg No.	Max Allowable Transmissible Torque at Below 50 rpm (in lbs.)	Speed of rotation (rpm)																								
		1	5	10	25	50	100	200	300	400	500	600	800	1000	1200	1500	1800	2000	2500	3000	3600	4000	4800			
4012	1921	0.03	.015	0.30	0.78	1.54	2.32	3.53	4.64	5.57	6.65	7.60	9.40	11.44	12.98	15.56	18.37	19.85	24.00	27.76	32.32	35.32	41.30			
4016	3416	0.05	0.28	0.55	1.38	2.76	4.14	6.29	8.27	9.94	11.87	13.54	6.76	20.52	23.20	28.16	32.72	35.27	42.78	49.62	57.66	62.89	73.62			
5016	6505	0.11	0.52	1.05	2.61	5.24	7.86	11.96	15.69	18.91	22.52	25.75	31.92	38.76	44.12	53.51	62.22	67.05	81.27	94.41	109					
5018	8240	0.13	0.67	1.33	3.33	6.64	9.96	15.15	19.98	23.87	28.56	32.72	40.36	49.08	55.79	67.72	78.85	85.02	103	120						
6018	15489	0.24	1.25	2.51	6.26	12.51	18.77	28.56	37.55	45.06	53.77	61.55	76.17	92.66	105	128	149	161	194							
6020	17868	0.28	1.43	2.88	7.21	14.34	21.55	23.72	43.17	51.85	61.90	70.84	87.59	106.58	121	147	171	185	223							
8018	34341	0.55	2.78	5.55	13.81	27.76	41.57	63.30	83.28	99.91	119	135	169	205	233	283	330	355								
8020	41027	0.66	3.30	6.61	16.49	33.05	49.55	75.17	99.22	118.54	141.3	162	201	244	278	337	393	423								
10020	77710	1.25	6.25	12.51	31.25	62.49	93.87	142	188	225	268	307	380	463	526	638	743									
Lubrication System		1					2					3														

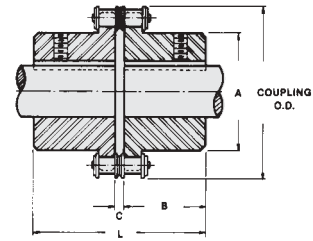

Standard RC Couplings Specification Table

Cplg No.	Std Finished Bores Incl. Std KW & 2 SS	Bore Dia.		A	B	C	L	Approx Cplg. OD.	Single Splt Wt. (lbs) Approx	Cplg Chain Wt. (lbs) Approx	Assembled Cplg Inertia (in lb sec ²)
		Min.	Max.								
4012	1/2, 5/8, 3/4	1/2	7/8	1 13/32	1 1/8	9/32	2 17/32	2 13/32	0.5	0.4	0.20 x 10 ⁻²
4016	5/8, 3/4, 7/8, 15/16 1, 1 1/8, 1 3/16*, 1 1/4*	1/2	15/16	1 31/32	1 1/8	9/32	2 17/32	3 1/32	1	0.6	0.60 x 10 ⁻²
5016	3/4, 7/8, 1, 1 1/8, 1 1 1/4, 1 3/8, 1 7/16, 1 1/2, 1 5/8*	5/8	1 1/16	2 1/2	1 7/16	3/8	3 1/4	3 25/32	2.2	1.2	1.89 x 10 ⁻²
5018	3/4, 7/8, 1, 1 1/8, 1 1 1/4, 1 3/8, 1 7/16, 1 1/2, 1 5/8, 1 3/4, 1 7/8*, 1 15/16*	5/8	2	2 31/32	1 11/16	3/8	3 3/4	4 3/16	3.5	1.4	3.39 x 10 ⁻²
6018	1, 1 1/8, 1 3/16, 1 1/4 1 7/16, 1 1/2, 1 5/8, 1 3/4, 1 7/8, 1 15/16, 2, 2 1/8, 2 3/16, 2 1/4, 2 3/8*, 2 7/16*	1	2 7/16	3 1/2	1 7/8	7/16	4 3/16	5	5	2.4	8.09 x 10 ⁻²
6020	1 1/8, 1 1/4, 1 1/2, 1 3/4 2 1/8, 2 3/8*, 2 7/16*, 2 5/8*	1	2 3/4	3 3/8	2	7/16	4 7/16	5 1/2	6.5	2.6	12.4 x 10 ⁻²
8018	1 1/8, 1 3/4, 1 15/16, 2 2 3/8, 2 7/16, 2 5/8, 2 7/8*, 2 15/16*	1 1/8	3 1/8	4 9/16	2 3/8	9/16	5 2 1/64	6 5/8	11	5.5	31.9 x 10 ⁻²
8020	1 1/2, 2 3/16, 2 7/16, 2 2 15/16, 3 1/8, 3 3/8*, 3 7/16*	1 1/8	3 9/16	5 3/8	2 5/8	9/16	5 1/2	7 9/32	16.3	6.1	53.8 x 10 ⁻²
10020	2, 3 3/8, 3 7/16, 3 15/16	1 1/2	4 5/8	6 23/32	3 1/8	23/32	6 31/32	9 1/8	31.8	10.8	158 x 10 ⁻²

Notes: The dimensions marked with an asterisk indicates set screws at 90 deg. from keyway.

Covers

Covers allow excellent lubrication, and their use is suggested on all applications to increase both product life and safety.

Cover Part No.	For Sizes	D	W	Wt. Lbs.	Cplg. Cover Inertia (in lb. sec ²)
40 Cover	4012 - 4016	4	2	.85	0.69 x 10 ⁻²
50 Cover	5016 - 5018	5 1/8	2 3/8	1.45	2.00 x 10 ⁻²
60 Cover	6018 - 6020	6 3/8	2 15/16	2.55	5.40 x 10 ⁻²
80 Cover	8018 - 8020	8 3/16	4	5.05	18.9 x 10 ⁻²
10020 Cover	10020	10 1/8	5 1/4	12.55	55.8 x 10 ⁻²

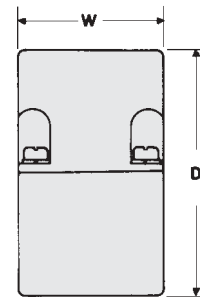

Aluminum covers are supplied with seals to cover the listed sizes.

Covers have a rounded exterior in order to offer protection to screw heads.



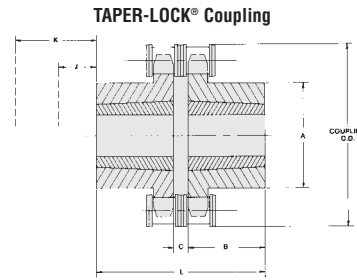
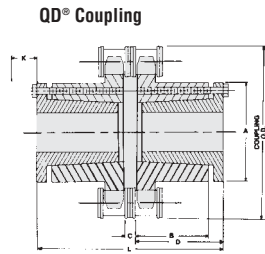

• QD® Couplings

Coupling Number	Bushing	Max. Torque (in lbs. unit)	Max. Bore*	A	B	C	D	L	Coupling O.D.	K**	Wt. Lbs.***
4016JA	JA	1000	1	2	7/8	9/32	1 1/16	2 23/32	3 3/32	1 1/4	.90
5018SH	SH	3500	1 3/8	2 3/32	1	3/8	1 1/2	3 3/8	4 1/16	1 3/4	1.30
6020SK	SK	7000	2 1/2	3 3/8	1 1/4	7/16	1 7/8	4 1/16	5 1/2	2 1/4	2.50
8018SF	SF	11,000	2 5/16	4 1/16	1 3/4	37/64	2 3/8	5 21/64	6 21/32	2 1/4	5.30

*Maximum bore indicated is the maximum bore suggested with standard keyway.
 **K dimension reflects the minimum clearance to remove the coupling half by using the screws as jack screws.
 ***Approximate weight of coupling half with bushing.

• TAPER-LOCK® Couplings

Type "TLH" Coupling Number	Type "TLF" Coupling Number	Max. Torque (in lbs. unit)	Bushing Used	Bushing Data Max. Bore	Min. Bore	A	B	C	J*	K**	L	Coupling O.D.	Wt. Lbs.***
4016TLH	4016TLF	1300	1108	1 1/8	1/2	1 31/32	7/8	9/32	5/8	3/4	2 1/32	3 1/32	.90
5018TLH	5018TLF	4300	1610	1 3/8	1/2	2 31/32	1	3/8	1 1/16	1 1/16	2 3/8	4 1/16	1.10
6020TLH	6020TLF	7150	2012	2	1/2	3 3/8	1 1/4	7/16	1 1/16	1 1/8	2 15/16	5 1/2	2.70
8020TLH	8020TLF	24,000	3020	3	1 1/16	5 3/8	2	37/64	1 1/16	2 1/16	4 37/64	7 19/64	6.10
10020TLH	10020TLF	44,800	3535	3 1/2	1 1/16	6 23/32	3 1/2	2 3/32	2	2 1/2	7 23/32	9 1/8	19.00

NOTE:
 For H type TAPER-LOCK bushing installs from the hub side of the flange.
 For F type TAPER-LOCK bushing installs from the face side.
 *Space required to tighten bushing with shortened hex key. Space is also required to loosen screws to permit the removal of the hub by the puller.
 **Space required to loosen bushing with shortened hex key using screws as jack screws. No puller is required.
 ***Approximate weight of coupling half with bushing.

QD® is a registered trademark of and is used under license from Emerson Electric Company.
 TAPER-LOCK® is a registered trademark of Reliance Electric Company.

Lubrication

Choose one of the following lubrication systems when using Roller Chain Couplings. The choice depends upon the operating speed. (Refer to the Horsepower Ratings, Table 2, pg.3.) Use NLGI grade 1 or 2 grease.

Lubrication System 1	Lubrication System 2	Lubrication System 3
Apply grease regularly once per month.	Apply grease regularly once a week, or install a coupling cover filled with grease.	Install a coupling cover filled with grease. Change the grease according to Table 4.

The amount of grease to apply is shown in Table 3. If these amounts are followed, there will be a slight amount of leakage at the beginning of the operation, but this will soon stop.

For System 3, it is especially important to use high-grade grease. Because of centrifugal force, there is a tendency for the grease to stick to the inner surface of the cover, resulting in inadequate lubrication.

Table 3. Amount of Grease to Apply

Coupling Cover Size	Amount (lb)
40 Cover	.16
50 Cover	.32
60 Cover	.71
80 Cover	1.41
100 Cover	3.00

Table 4. Grease Change Interval for use with Coupling Cover

Operating Conditions	First change	Interval after first change
More than 1/2 max. speed	1,000 hours	2,000 hours
Less than 1/2 max. speed	2,000 hours	4,000 hours

Installation

1. Place the oil seals for the cover on the sprocket halves.

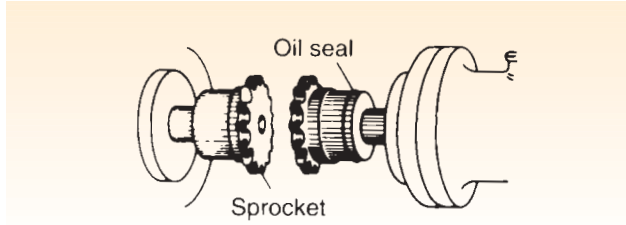

2. Bring the sprocket faces close together and correct the angular and offset misalignment.

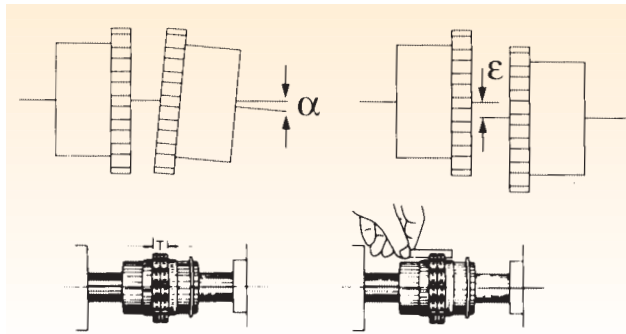

Adjust the angular misalignment (alpha symbol) so that the width of the tooth surface T is the same around the circumference of the sprockets. The allowable angular misalignment α is 1° .

Place a straight edge at the bottom of corresponding teeth of the two sprockets and adjust so that the offset misalignment is minimized. The allowable offset misalignment ϵ is 2% of the chain pitch.

When the sprocket speed is $1/3$ or more of the maximum speed (i.e., it lies on the right side of the dark line in the Horsepower Rating table, pg.3), the allowable angular and offset misalignments are 0.5° and 1% of the chain pitch.

3. Measure the distance "C" between the sprocket faces and firmly fasten the set bolt (refer to Specifications table, pg.4).
4. Lubricate the chain with grease, then wrap the chain around both sprockets and fix with the connecting pin.
5. Fill the required quantity of grease into both sides of case and fasten them firmly. Do not forget to use gaskets.

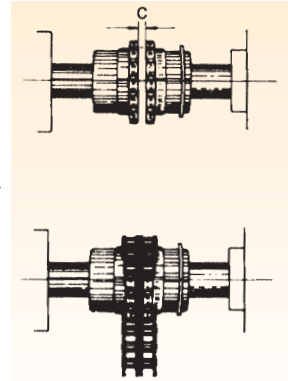

- Notes:**
1. During high-speed operations or conditions of large vibration, please use locking cement when fastening the bolts.
 2. Install a cover when there is a risk of chain breakage.
 3. Ambient temperature range is 14° to 140°F . If you will use the coupling outside this temperature range, please consult with U.S. Tsubaki.



U.S. Tsubaki— Roller Chain Coupling



- Connect quickly and easily
- Handle high torque
- Keep your profits turning



U.S. Tsubaki, Inc.
Headquarters
301 E. Marquardt Drive
Wheeling, IL 60090
Tel: (800) 323-7790
Tel: (847) 459-9500
Fax: (847) 459-9515
Web Site: www.ustsubaki.com

Service Centers

Atlanta, GA
U.S. Tsubaki, Inc.
675 Wesleyan Drive, S.W.
Atlanta, GA 30336
Tel: (800) 443-8212
Tel: (404) 349-7973
Fax: (404) 349-7975

Charlotte, NC
B.C. & H. Company
11010 Monroe Road
Matthews, NC 28105
Tel: (704) 847-9131
Fax: (704) 847-3651

Chicago, IL
U.S. Tsubaki, Inc.
301 E. Marquardt Drive
Wheeling, IL 60090
Tel: (800) 323-7790
Tel: (847) 459-9500
Fax: (847) 459-9515

Dallas, TX
Robco, Inc.
1523 Crescent Drive
Carrollton, TX 75006
Tel: (972) 242-3300
Fax: (972) 245-2328

Los Angeles, CA
U.S. Tsubaki, Inc.
18031 Cortney Court
City of Industry, CA 91748
Tel: (800) 352-4315
Tel: (626) 913-1344
Fax: (626) 913-5042

Philadelphia, PA
U.S. Tsubaki, Inc.
2321 N. Penn Road
Hatfield, PA 19440
Tel: (800) 258-3847
Tel: (215) 997-9170
Fax: (215) 997-9179

Portland, OR
U.S. Tsubaki, Inc.
14157 N.E. Airport Way
Portland, OR 97230
Tel: (800) 352-4315
Fax: (626) 913-5042

Manufacturing Facilities

Bennington, VT
Sprocket Division
222 Bowen Road
Bennington, VT 05201
Tel: (800) 451-4441
Tel: (802) 447-7561
Fax: (802) 447-0755

Holyoke, MA
Roller Chain Division
821 Main Street
Holyoke, MA 01040
Tel: (800) 628-9037
Tel: (413) 536-1576
Fax: (413) 534-8239

Sandusky, OH
Engineering Chain Division
1010 Edgewater Drive
Sandusky, OH 44870
Tel: (800) 537-6140
Tel: (419) 626-4560
Fax: (419) 626-5194

Mississauga, ON
Tsubaki of Canada Limited.
1630 Drew Road
Mississauga, ON
Canada L5S 1J6
Tel: (800) 263-7088
Tel: (905) 676-0400
Fax: (905) 676-0904

Distributed by:

NOTE: IN ACCORDANCE WITH THE POLICY OF U.S. TSUBAKI, INC., TO CONSISTENTLY IMPROVE ITS PRODUCTS, THE SPECIFICATIONS IN THIS BROCHURE ARE SUBJECT TO CHANGE WITHOUT NOTICE. **FOR CURRENT TERMS AND CONDITIONS OF SALE, SEE OUR CURRENT PRICE LIST.**