

# **TSUBAKI**<sup>®</sup>

DIVISIONAL PRODUCT GUIDE



ANSI



Large & Small Pitch



Heavy, Super & Ultra



Double Pitch



Leaf

Attachment



Carbon Steel & Stainless Steel



Hollow Pin

Lube-Free



LAMBDA®

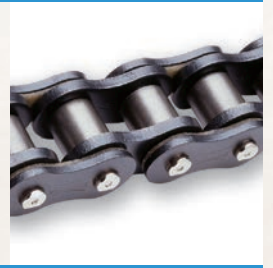

Xceeder® (Felt Seal)

Corrosion Resistant



Stainless Steel



Nickel-Plated



Neptune®

Plastic



Industrial Plastic  
Poly Steel

Specialty



British Standard



Energy Series® (Oil & Gas)



Thermoformer



Vacuum Wrapper &  
Gripper



Pin Oven

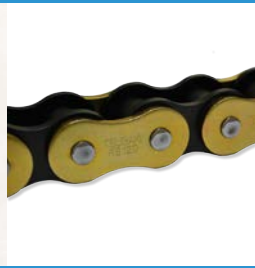

Titan™



Free-Flow



Made-to-Order



Drive



Straight Sidebars & Offset Sidebars

Roller Conveyor



Roller Conveyors



Extended Pins & High Sidebars



A and K Attachments



G Attachments



M Attachments

Apron Conveyor

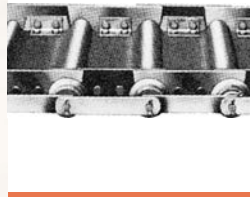

Style A and B

Bar & Pin



Linear Fixed & Double Flex

Welded Steel



Welded Steel

Steel Bushed



Steel Bushed



Bucket Elevator

Sealed



Patented Sealed Joint

Drop Forged Rivetless



Drop Forged Rivetless



Barloop



Caterpillar Drive

Specialty



Bi-Planar



Flanged Rollers and Cottered Pins



Forged Continuous & Straight Pull Miner



Outboard Roller

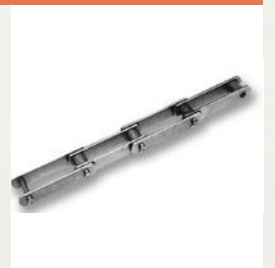

Water Screen

SPROCKETS



Roller Chain

Stainless Steel

Engineering Class

Made-To-Order



Double Single

Double Pitch

Multi-Strand

Idler

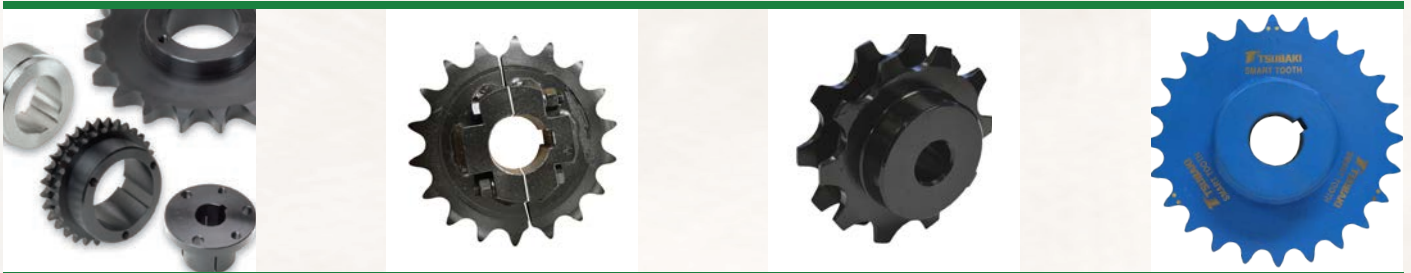

Split Taper

Steel Split

Double Plus®

SMART TOOTH™ with patented Wear Indicators

PT COMPONENTS



Overrunning Clutches & Backstops

Power Cylinder (Electric Actuator)

POWER-LOCK®

Couplings



Gear Motor

Shock Relay/Overload Protection

Torque Shield & Torque Limiter

Linear Shield



## MONO - Molded Plastic



Micro-Sized



EASYTRAX



QUICKTRAX



UNIFLEX Advanced

## VARIO - Customizable Basic, Modular & Hybrid



K Series



MC Series



MK Series



XL Series

## Tube - Enclosed



TKA Series



MT Series



S Series



CONDUFLEX

## Steel - Heavy Duty



LS Series



S/SX Series



Super-Duty

## Long Travel

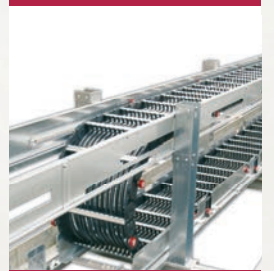

RCC - Rolling Carriage

## 3D Motion

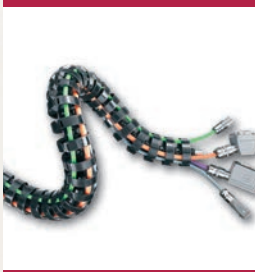

ROBOTRAX

## Turn-Key



MC Series

## Cables



Continuous-Flex

## Accessories

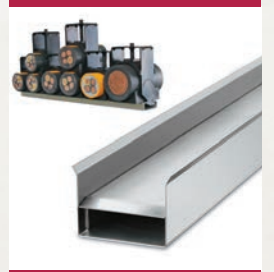

Guide Channels

# U.S. Tsubaki now offers an extensive inventory of Overrunning and Indexing Clutches and Backstops

Tsubaki is bringing over 50 years of global experience in the design and manufacture of clutch products to the Americas. The product variations shown below feature a series of unique cam designs to maximize the torque rating, achieve low speed lift-off to minimize wear in the overrunning condition and provide long maintenance free service. Simple and cost effective, Tsubaki clutches transmit the load in one direction (freewheel) and stop and hold any reversing loads to prevent damage.

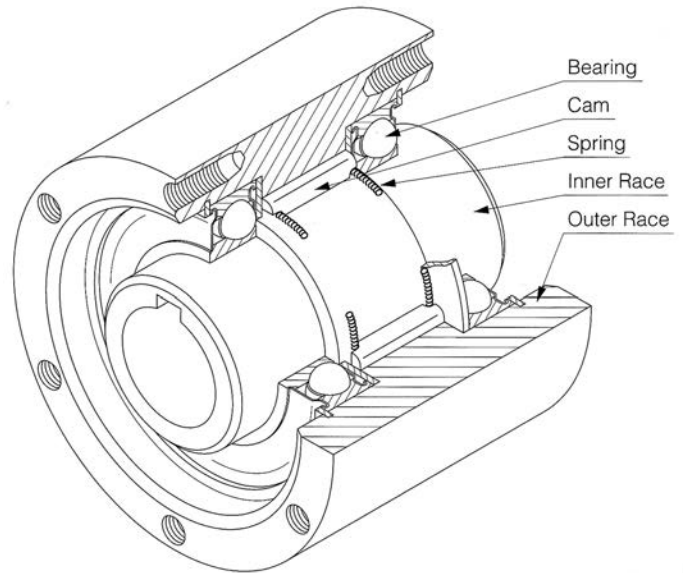

## Backstopping



**BS/BS-HS**



**BSEU**

## High Speed Backstopping



**BR-HT**

## Long-Life Modular Design



**BREU**

## Indexing



**MIUS**



**MZEU**

## One-Way Bearing

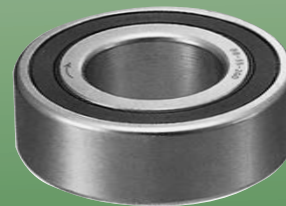

**BB**

For more information on our clutch product offerings, pricing or to request a catalog, please contact us:  
**800-323-7790** or visit [www.ustsubaki.com](http://www.ustsubaki.com)



# Unmatched Quality, Dependability, Service & Support



SMART TOOTH™  
Sprockets



Sealed Joint  
Chain Options



Steel Cable  
Carriers



Backstops &  
Overrunning  
Clutches



Lube-Free  
Lambda® Chain





Continuous-Flex  
Cables

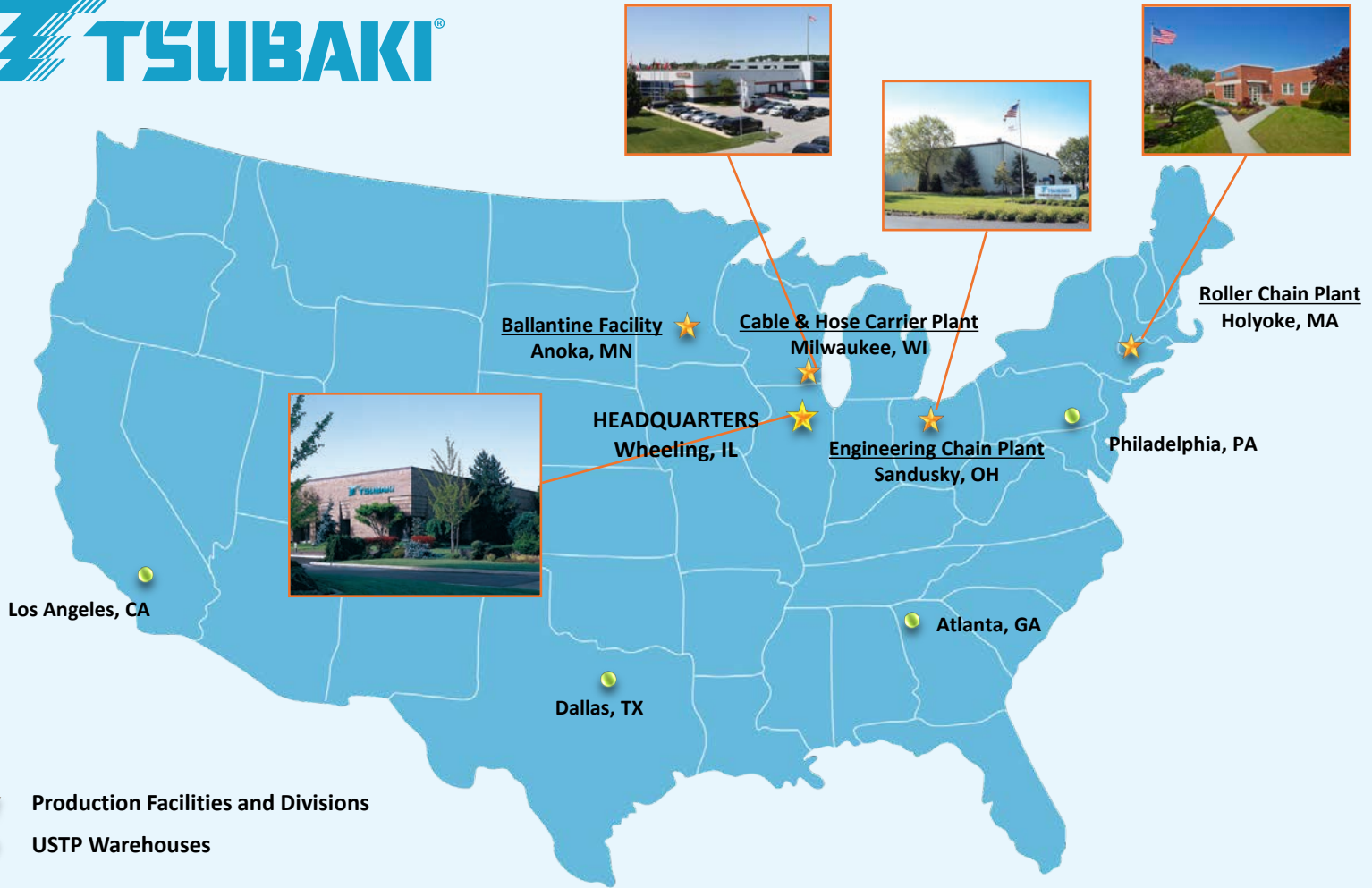

Here are just some of Tsubaki's  
Premium Problem Solving Products

# U.S. Tsubaki Power Transmission Footprint



-  **Production Facilities and Divisions**
-  **USTP Warehouses**

## Additional Manufacturing Facilities



World Headquarters  
Kyotanabe City, Japan  
*Most Advanced Chain Facility in the World*



Sprocket Manufacturing  
Mississauga, Ontario Canada  
*Specialized Made-to-Order Sprocket Capabilities*

## Contact Information

**U.S. Tsubaki Power Transmission, LLC.**  
**Corporate Headquarters**  
301 E. Marquardt Drive  
Wheeling, IL 60090  
Tel: (800) 323-7790  
Fax: (847) 459-9515  
www.ustsubaki.com

Roller Chain Division  
821 Main Street  
Holyoke, MA 01040  
Tel: (800) 323-7790

Conveyor & Construction  
Chain Division  
1010 Edgewater Drive  
Sandusky, OH 44870  
Tel: (800) 537-6140  
Fax: (419) 626-5194

Cable & Hose Carrier Division  
7100 W. Marcia Rd.  
Milwaukee, WI 53223  
Tel: (800) 443-4216  
Fax: (414) 354-1900