

Operating Manual

V-Drive Advanced / Value / Basic VT⁺, VH⁺, VS⁺ / NVH, NVS / CVH, CVS



WITTENSTEIN alpha GmbH

Walter-Wittenstein-Straße 1
D-97999 Igersheim
Germany



Motor-mounting video

Customer Service department

		✉)
Deutschland	WITTENSTEIN alpha GmbH	service@wittenstein-alpha.de	+49 7931 493-12900
Benelux	WITTENSTEIN BVBA	service@wittenstein.biz	+32 9 326 73 80
Brasil	WITTENSTEIN do Brasil	vendas@wittenstein.com.br	+55 15 3411 6454
中国	威騰斯坦（杭州）实业有限公司	service@wittenstein.cn	+86 571 8869 5856
Österreich	WITTENSTEIN GmbH	office@wittenstein.at	+43 2256 65632-0
Danmark	WITTENSTEIN AB	info@wittenstein.dk	+45 4027 4151
France	WITTENSTEIN sarl	info@wittenstein.fr	+33 134 17 90 95
Great Britain	WITTENSTEIN Ltd.	sales.uk@wittenstein.co.uk	+44 1782 286 427
Italia	WITTENSTEIN S.P.A.	info@wittenstein.it	+39 02 241357-1
日本	ヴァイツェンシュタイン株式会社	sales@wittenstein.jp	+81-3-6680-2835
North America	WITTENSTEIN holding Corp.	technicalsupport@wittenstein-us.com	+1 630-540-5300
España	WITTENSTEIN S.L.U.	info@wittenstein.es	+34 93 479 1305
Sverige	WITTENSTEIN AB	info@wittenstein.se	+46 40-26 50 10
Schweiz	WITTENSTEIN AG Schweiz	sales@wittenstein.ch	+41 81 300 10 30
台湾	威騰斯坦有限公司	info@wittenstein.tw	+886 3 287 0191
Türkiye	WITTENSTEIN Güç Aktarma Sistemleri Tic. Ltd. Şti.	info@wittenstein.com.tr	+90 216 709 21 23

© WITTENSTEIN alpha GmbH 2020

Subject to technical and content changes without notice.

Table of Contents

1	About this manual	3
1.1	Information symbols and cross references	3
1.2	Scope of delivery	3
2	Safety	4
2.1	EC/EU Directive	4
2.1.1	Machinery Directive	4
2.2	Personnel	4
2.3	Intended use	4
2.4	Reasonably foreseeable misuse	5
2.5	General safety instructions	5
2.6	Structure of warning instructions.....	6
2.6.1	Safety symbols	6
2.6.2	Signal words.....	7
3	Description of the gearbox	8
3.1	Overview of gearbox components	8
3.1.1	Version with through-holes	8
3.1.2	Version with threaded bores.....	8
3.2	Name plate.....	9
3.3	Ordering code	9
3.4	Dimensions and performance data	10
3.5	Information about the lubricant	10
3.6	Notes regarding the IP protection class	10
4	Transport and storage	11
4.1	Packaging	11
4.2	Transport.....	11
4.2.1	Transport of gearboxes up to size 063	11
4.2.2	Transport of gearboxes size 080 and up	12
4.3	Storage	12
5	Assembly	13
5.1	Preparations.....	13
5.2	Mounting the motor to the gearbox	14
5.3	Mounting the gearbox on a machine.....	16
5.3.1	Mounting with through-holes	16
5.3.2	Mounting with slotted holes.....	17
5.3.3	Mounting with threaded bores	18
5.4	Components mounted to the output side	18
5.4.1	Mounting with shrink disk	19
6	Startup and operation	20
7	Maintenance and disposal	21
7.1	Maintenance schedule	21
7.2	Maintenance work	21
7.2.1	Visual inspection	21
7.2.2	Checking the tightening torques	21
7.3	Startup after maintenance work	21
7.4	Disposal	21

8 Malfunctions	22
9 Appendix	23
9.1 Specifications for mounting to a motor	23
9.2 Specifications for mounting to a machine.....	24
9.2.1 Specifications for mounting with threaded holes	24
9.2.2 Specifications for mounting with through-holes	25
9.3 Specifications for mounting to the output side.....	25
9.3.1 Mounting on the keyed hollow shaft	26
9.4 Specifications for startup and operation	26
9.4.1 Mounting position.....	27
9.4.2 Continuous operation.....	28
9.5 Tightening torques for common thread sizes in general mechanical engineering	28

1 About this manual

This operating manual contains necessary information to safely operate the gearbox.

If this manual is supplied with an amendment (e.g. for special applications), then the information in the amendment is valid. Contradictory specifications in this manual thereby become void.

The operator must ensure that all persons assigned to install, operate, or maintain the gearbox have read and understood these instructions in full.

Store these instructions within reach of the gearbox.

Inform colleagues who work in the area around the machine about the **safety and warning notices** to avoid injuries.

The original instructions were prepared in German; all other language versions are translations of these instructions.

1.1 Information symbols and cross references

The following information symbols are used:

- Indicates an action to be performed
- ➔ Indicates the results of an action
- ① Provides additional information about the action

A cross reference refers to the chapter number and the header of the target section (e. g. 2.3 "Intended use").

A cross reference on a table refers to the table number (e. g. Table "Tbl-15").

1.2 Scope of delivery

- Check the completeness of the delivery against the delivery note.
 - ① Missing parts or damage must be notified immediately in writing to the carrier, the insurance company, or **WITTENSTEIN alpha GmbH**.

2 Safety

These instructions, especially the safety and warning notices and the rules and regulations valid for the operating site, must be observed by all persons working with the gearbox.

The following, especially, must be strictly adhered to:

- Observe the instructions for transport and storage.
- Use the gearbox only in accordance with its intended use.
- Carry out maintenance and repair work appropriately and professionally in conformity with the specified intervals.
- Always mount, dismantle, and operate the gearbox properly (e.g. even test run only with secure mounting).
- The manufacturer of the higher-level machine shall, in accordance with its risk assessment, install protective devices and equipment as appropriate to protect the user from the residual hazards of the gearbox. Only operate the gearbox with intact and active protective devices and equipment.
- Only operate the gearbox with the correct lubricant (type and amount).
- Prevent the gearbox from becoming extremely soiled.
- Only carry out modifications or reconstructions when these are approved in writing by the **WITTENSTEIN alpha GmbH**.

Personal injuries or material damage, or other claims arising from non-observance of these minimum requirements, are the sole responsibility of the operator.

In addition to the safety-related information in this manual, also observe any legal and otherwise applicable rules and regulations, particularly for accident prevention (e.g. personal safety equipment) and environmental protection.

2.1 EC/EU Directive

2.1.1 Machinery Directive

The gearbox is considered a "machine component" and is therefore not subject to the EC Machinery Directive 2006/42/EC.

Startup is prohibited within the scope of the EC directive until it has been determined that the machine in which this gearbox is installed corresponds to the regulations within this directive.

2.2 Personnel

Only technicians who have read and understood this operating manual may perform work on the gearbox. Based on their training and experience, technicians must be able to evaluate the tasks assigned to them, in order to recognize and avoid risks.

2.3 Intended use

The gearbox serves to convert torques and speeds. It is suitable for all industrial applications.

The gearbox may not be operated in areas with potentially explosive atmosphere.

In food processing / pharmaceutical / cosmetics, the gearbox may only be used next to or under the product area. Product-specific deviation regarding the positioning and mounting position are described in Chapter 3 "Description of the gearbox".

The gearbox has been constructed according to current technological standards and accepted safety regulations.

- To avoid danger to the operator or damage to the machine, apply the gearbox only for its intended use and in a technically flawless and safe state.
- If you notice any altered operating behavior, check the gearbox in accordance with Chapter 8 "Malfunctions".
- Read the general safety instructions before beginning to work (see Chapter 2.5 "General safety instructions").

The gearbox is intended for installation on motors that:

- correspond to the design B5 (in the event of deviations, consult our Customer Service department [Technical Customer Service department]).
- have a radial and axial runout tolerance according to DIN EN 50347.
- have a cylindrical shaft end with tolerance class h6 to k6.
 - ① For motor shaft diameter 55 mm and up, m6 is also permissible.

Screw connections between gearbox and attached component such as motors have to be calculated, dimensioned, mounted, and tested according to current technological standards. Use the VDI directives VDI 2862 sheet 2 and VDI 2230 for example.

- ① The tightening torques recommended by us can be found in Chapter 9 "Appendix".

Deviating from the recommendations in Chapter 5 "Assembly", washers may be used if the material of the screw surface features a too low interface pressure.

- ① The hardness of the washer needs to match the property class of the screw.
- ① Take into account the washer for the screw calculation (joint, additional compression set, surface pressure under screw head and under washer).

2.4 Reasonably foreseeable misuse

Any use is prohibited if

- it contradicts the requirements of chapter 2.3 "Intended use",
- it exceeds the permissible technical data, e.g. speed, force and torque load, temperature, service life (see also chapter 3.4 "Dimensions and performance data").

2.5 General safety instructions

The operation of the gearbox involves residual risks even when adhering to the intended use.

Rotating components can cause serious injuries:

- Before startup, remove objects, loose components (e.g. feather keys), and tools from the gearbox, in order to avoid danger from thrown parts.
- Keep a sufficient distance to moving machine components when the gearbox is running.
- Secure the higher-level machine against restarting and unintentional movements during assembly and maintenance work (e.g. uncontrolled lowering of lifting axes).

A **hot gearbox** can cause serious burns:

- Touch the hot gearbox only with protective gloves.

The **noise emissions** can cause hearing damage. The continuous noise pressure level may vary according to product type and gearbox size:

- ① Information about your gearbox is available in the customized performance data (X093-D...), in the catalog under www.wittenstein-alpha.de, or from our Customer Service / Sales department.
- For noise protection measures, observe the total noise pressure level of the machine.

Loose or overloaded screw connections can cause damage to the gearbox:

- Use a calibrated torque wrench to tighten and check all screw connections for which tightening torques have been specified.

Solvents and lubricants are flammable, can cause skin irritation, and can pollute soil and water:

- In case of fire: Do not use a jet of water to extinguish.
 - ① Suitable extinguishing agents are powder, foam, water mist and carbon dioxide. Observe the safety instructions of the lubricant manufacturer (see Chapter 3.5 "Information about the lubricant").
- Use protective gloves to avoid direct skin contact with solvents and lubricants.
- Use and dispose of cleaning solvents and lubricants properly.

A **damaged gearbox** can cause accidents and injury:

- Immediately shut down a gearbox that has been overloaded due to misuse or a machine crash (see Chapter 2.4 "Reasonably foreseeable misuse").
- Replace the damaged gearbox, even if no external damage is visible.

2.6 Structure of warning instructions

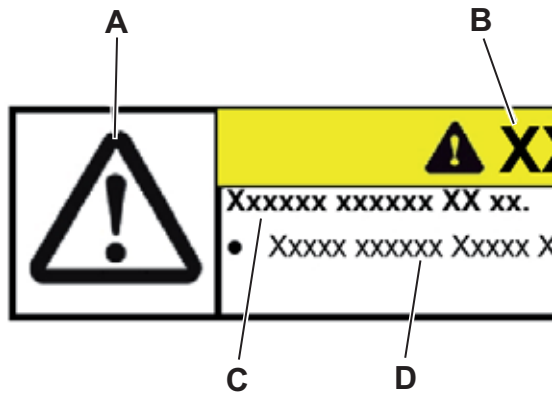

Warning instructions are situation-specific. They will be precisely where tasks are described in which dangers can arise.

The warning instructions in this manual are designed according to the following pattern:

A = Safety symbol (see Chapter 2.6.1 "Safety symbols")

B = Signal word (see Chapter 2.6.2 "Signal words")

C = type and consequence of danger

D = avoiding danger

2.6.1 Safety symbols

The following safety symbols are used to indicate possible hazards, prohibitions, and important information:



General hazard



Hot surface



Suspended loads



Entanglement



Environmental protection



Information

2.6.2 Signal words

The following signal words are used to indicate possible hazards, prohibitions, and important information:

	<p style="text-align: center;">⚠ DANGER</p> <p>This signal word indicates an imminent danger that will cause serious injuries or even death.</p>
	<p style="text-align: center;">⚠ WARNING</p> <p>This signal word indicates a potential hazard that could cause serious injuries and even death.</p>
	<p style="text-align: center;">⚠ CAUTION</p> <p>This signal word indicates a potential hazard that could cause minor or serious injuries.</p>
	<p style="text-align: center;">NOTICE</p> <p>This signal word indicates a potential hazard that could lead to material damage.</p>
	<p>A note without a signal word indicates application hints or especially important information for handling the gearbox.</p>

3 Description of the gearbox

The gearbox is a single- or multi-stage low-backlash servo worm gearbox.

The gearbox must only be operated in mounting position as specified in the order.

Various types of motors can be accommodated using an adapter plate and, where necessary, a bushing.

The gearbox is equipped with an integrated linear length compensation to compensate for the expansion of the motor shaft when heated up.

3.1 Overview of gearbox components

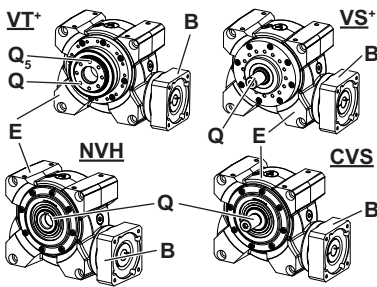
		Gearbox components	
	E	Gear housing	
	Q	Output shaft / Output flange	
	Q ₅	For an indexing pin for mechanically zeroing the gearbox/the application.	
	B	Adapter plate	

Tbl-1: Overview of gearbox components VT⁺ / VS⁺ / NVH / CVS

3.1.1 Version with through-holes

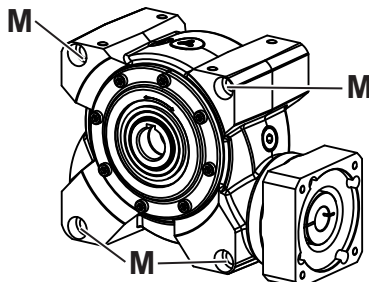
		Gearbox components	
	M	Through-holes (see Chapter 5.3.1 "Mounting with through-holes")	

Tbl-2: Version with through-holes

3.1.2 Version with threaded bores

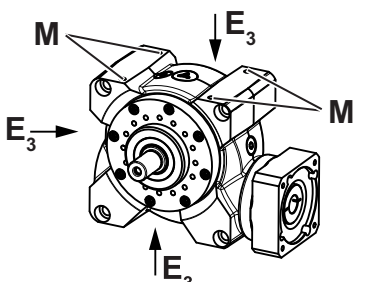
		Gearbox components	
	E ₃	Housing surface (Gear housing)	
	M	Threaded holes (see Chapter 5.3.3 "Mounting with threaded bores")	

Tbl-3: Version with threaded bores

		Gearbox components VT ⁺ / VS ⁺
	M	Threaded holes (see Chapter 5.3.3 "Mounting with threaded bores")

Tbl-4: Version with threaded bores

3.2 Name plate

The identification plate is attached to the gear housing or the input flange.

		Designation
	A	Ordering code (see Chapter 3.3 "Ordering code")
	B	Ratio i
	C	Customer material number (optional)
	D	Serial number
	E	Lubricant
	F	Production date
	G	Data matrix code (optional)

Tbl-5: Identification plate (sample values)

3.3 Ordering code

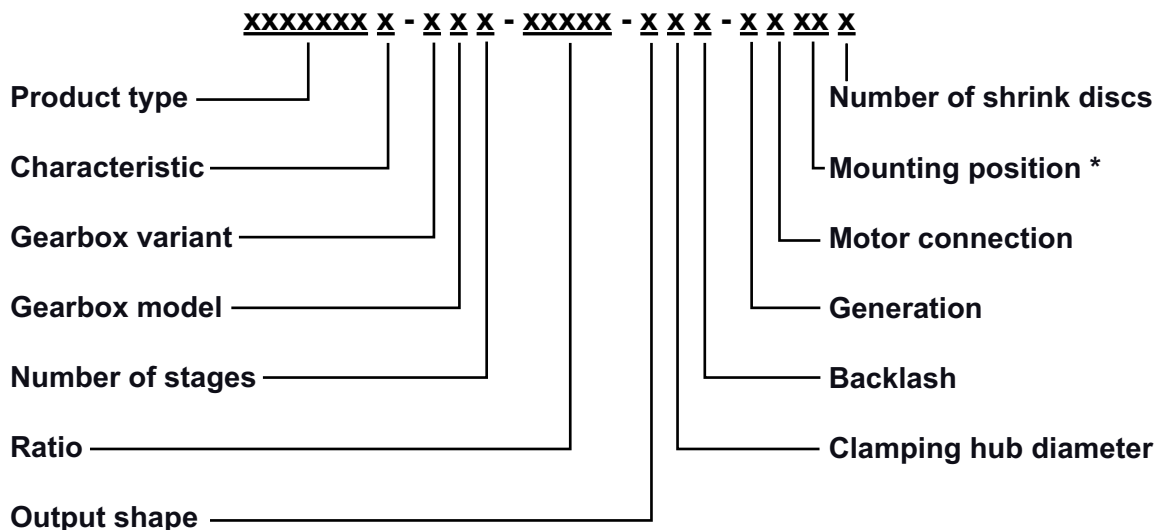

* For further information on the mounting position, please refer to Chapter 9.4.1 "Mounting position". More information is available in our catalog or at www.wittenstein-alpha.de.

3.4 Dimensions and performance data

The dimensions, the maximum permissible speeds and torques, and information on the service life can be found

- in our catalog,
- at www.wittenstein-alpha.de,
- in the specification software **cymex**[®],
- in the respective customized performance data (X093–D...).

① Consult our Customer Service department if the gearbox is older than a year. The user will then receive the valid performance data.

3.5 Information about the lubricant

	All gearboxes are permanently lubricated by the manufacturer with synthetic gear oil (polyglycols) or with a high-performance grease (see identification plate). All bearings are lubricated for life at the factory.
---	--

3.6 Notes regarding the IP protection class

	The products comply with the protection class according to the catalog in accordance with EN 60529. Except for special versions, they are not corrosion-protected and must be operated in a clean, dust-free and dry environment. Moisture penetration in the area of the drive is inadmissible. In this connection, we recommend additional protection measures or alternative products.
--	--



4 Transport and storage

4.1 Packaging

The gearbox is delivered packed in foil and cardboard boxes.

- Dispose of the packaging materials at the recycling sites intended for this purpose. Observe the applicable national regulations concerning disposal.

4.2 Transport

	⚠ WARNING
	<p>Suspended loads can fall and can cause serious injuries and even death.</p> <ul style="list-style-type: none"> • Do not stand under suspended loads. • Secure the gearbox before transport with suitable fasteners (e.g. belts).
	NOTICE
	<p>Impacts, for instance from falling or hard dropping, may damage the gearbox.</p> <ul style="list-style-type: none"> • Only use hoisting equipment and lifting accessories with sufficient capacity. • Never exceed the maximum permissible load for hoisting equipment. • Lower the gearbox slowly. <p>Applies only to gearboxes VT*:</p> <p>The hollow shaft is not suitable for the transmission of force. Deformations or leakages can occur.</p> <ul style="list-style-type: none"> • Only attach the lifting accessories (e.g. loops) to the outer side of the housing. • Never lift the gearbox by reaching into the openings of the hollow shaft.

The table "Tbl-6" specifies the maximum gearbox weights. Depending on the version, the actual weight can be considerably less.

Gearbox size V...	040	050	063	080	100
Maximum weight [kg]	5.6	9.7	16.7	35.5	64.6
Gearbox size NV... / CV...	040	050	063	080	100
Maximum weight [kg]	5.6	8.7	13.7	-	-

Tbl-6: Maximum weight [kg]

4.2.1 Transport of gearboxes up to size 063

No special method is specified for transporting the gearbox.

4.2.2 Transport of gearboxes size 080 and up

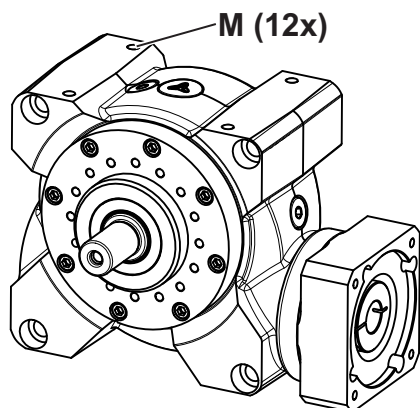

For gearboxes size 080 and up, we recommend the use of hoisting equipment.

You can screw in eye bolts (e.g. acc. to DIN 580) into the threaded bores [M] in the housing. The eye bolts (at least 2) are used for attaching the gearbox securely to the hoisting equipment.

① For specifications on the threaded bores, refer to Chapter 9.2 "Specifications for mounting to a machine".

4.3 Storage

Store the gearbox in horizontal position and dry surroundings at a temperature of 0 °C to +40 °C in the original packaging. Store the gearbox for a maximum of 2 years. Consult our Customer Service department if the conditions are different.

For storage logistics, we recommend the "first in - first out" method.

5 Assembly

- Read the general safety instructions before beginning to work (see Chapter 2.5 "General safety instructions").
- If you have questions about correct mounting, consult our Customer Service department.

5.1 Preparations

	NOTICE
	<p>Pressurized air can damage the gearbox seals.</p> <ul style="list-style-type: none"> • Do not use pressurized air to clean the gearbox.
	<p>Directly sprayed cleaning agents can alter the frictional values of the clamping hub.</p> <ul style="list-style-type: none"> • Only spray cleaning agents onto a cloth for wiping off the clamping hub.
	<p>Operation without an adapter plate might lead to damage.</p> <ul style="list-style-type: none"> • Only install your own adapter plate or replace an adapter plate according to the specifications of WITTENSTEIN alpha GmbH. Our Customer Service department will provide you with disassembly instructions for this purpose. • Operation without an adapter plate is prohibited.
	<p>In rare cases, a grease lubricated gearbox may show a small leak at the input (sweating).</p> <p>To prevent seeping, we recommend to seal the surfaces between</p> <ul style="list-style-type: none"> - adapter plate and drive housing (gearbox), as well as between - adapter plate and motor, <p>using a surface sealing adhesive (e.g. Loctite® 573 or 574).</p>

- Make sure that motor meets the requirements in Chapter 2.3 "Intended use".
- Select the screws for fastening the motor to the adapter plate according to the motor manufacturer's specifications. Observe the minimum screw-in depth in relation to the property class (see Table "Tbl-7").

Property class of screws for fastening the motor	8.8	10.9	Ax-70	Ax-80
Minimum screw-in depth	1.5 x d	1.8 x d	1.5 x d (*)	
d = Screw diameter				
(*) Only use a tool that is suitable for working with stainless steel.				

Tbl-7: Minimum screw-in depth of screws for fastening the motor to the adapter plate

- Clean/degrease and dry the following components using a clean and lint-free cloth, and a grease-dissolving, non-aggressive cleaning agent:
 - All fitting surfaces to neighboring components
 - Centering
 - Motor shaft
 - Inner diameter of clamping hub
 - Bushing, inside and out
- Dry all fitting surfaces to neighboring components in order to achieve the proper friction values of the screw connections.
- In addition, check the fitting surfaces for damage and impurities.

5.2 Mounting the motor to the gearbox

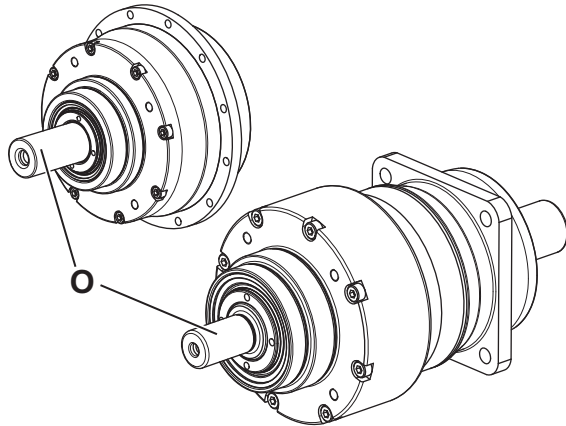

① **Only** the “self-contained version” gearbox variant with a drive shaft [O] is **not** intended for motor mounting. It is possible to drive the gearbox directly via the drive shaft, e.g. by means of a belt pulley.

For all gearboxes **with** motor-mounting, the following information applies:

	<ul style="list-style-type: none"> ● Observe the specifications and safety instructions of the motor manufacturer. ● Observe the safety and processing instructions for the threadlocker to be used. <p>Valid only for corrosion resistant gearboxes and gearboxes in Hygienic Design:</p> <ul style="list-style-type: none"> ● Align the geometry of the seal surfaces before mounting the motor. ● For corrosion resistant gearboxes, use sealing adhesives (e. g. Loctite® 573) to avoid leaks. ● Place an appropriate sealing ring between adapter plate and motor for gearboxes in Hygienic Design to avoid leaks. <p>① In addition, WITTENSTEIN alpha GmbH offers a suitable sealing plate.</p>
--	--

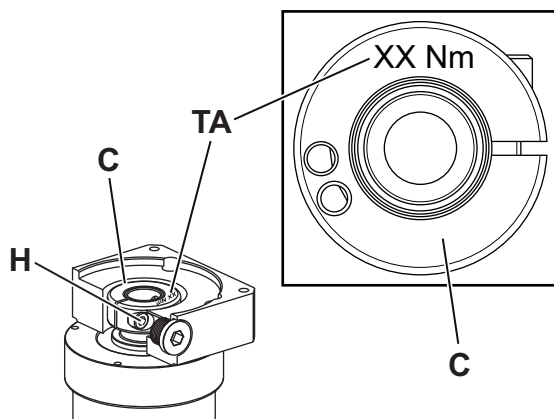

The tightening torque value [TA] of the clamping bolt [H] can be found on the clamping hub [C].

① The value for the tightening torque can also be found in Chapter 9.1 "Specifications for mounting to a motor".

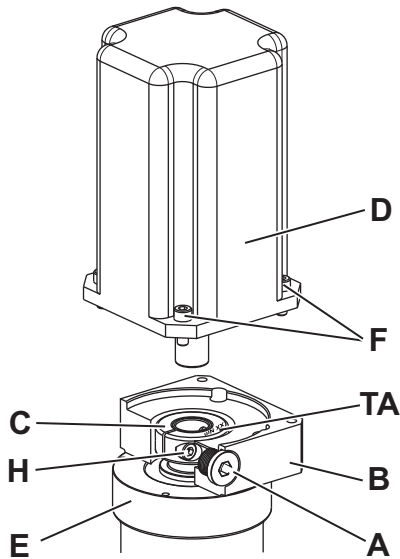

- Preferably, the motor should be mounted in a vertical orientation.
 - Remove the locking screw / stopper plug [A] from the mounting bore in the adapter plate [B].
 - Rotate the clamping hub [C] until the clamping bolt [H] can be reached via the mounting bore.
 - Loosen the clamping bolt [H] of the clamping hub [C] by one revolution.
 - Slide the motor shaft into the clamping hub of the gearbox [E].
- ① The motor shaft should slide in easily. If this is not the case, the clamping bolt needs to be loosened some more.

- ① If the clamping bolt [H₁] is loosened too far or removed, the clamping ring [I] can rotate on the clamping hub. Align it so that the clamping bolt [H₁] is in the keyway of the clamping hub (see table "Tbl-8").
- ① For certain motor shaft diameters and applications, a slotted bushing needs to be installed in addition.
- ① For the version with **clamping bolt, eccentric [H₁]**:
 The slot of the bushing (if present) and the clamping hub must be flush with the groove (if present) of the motor shaft; see Table "Tbl-8".
- For the version with **clamping bolt, central [H₂]**:
 The slots of the bushing (if present) and clamping hub have to be aligned with the keyway (if present) of the motor shaft and rotated 90° from the clamping bolt, see Table "Tbl-8".
- ① No gap is permitted between the motor [D] and the adapter plate [B].

		Designation
	H ₁	Clamping bolt, eccentric
	H ₂	Clamping bolt, central
	I	Clamping ring
	J	Bushing
	K	Keyed motor shaft
	L	Motor shaft with shaft key
	L ₁	Shaft key

Tbl-8: Arrangement of motor shaft, clamping bolt and bushing

- Apply threadlocker (e. g. Loctite® 243) to the four screws [F].
- Fasten the motor [D] onto the adapter plate [B] with the four screws. Evenly tighten the screws crosswise with increasing torque.
- Tighten the clamping bolt [H] of the clamping hub [C].
 - ① The value for the tightening torque can also be found in Chapter 9.1 "Specifications for mounting to a motor".
- For the version with a **stopper plug [A]**, push the plug into the adapter plate [B] all the way to the stop.

For the version with a **locking screw [A]**, turn the screw into the adapter plate [B].

① For screw size and specified tightening torque, see Table "Tbl-9".

Width across flats [mm]	5	8	10	12
Tightening torque [Nm]	10	35	50	70

Tbl-9: Tightening torques for the locking screw

5.3 Mounting the gearbox on a machine

	<ul style="list-style-type: none"> ● Observe the safety and processing instructions for the threadlocker to be used.
--	---

- Center the gearbox in the machine bed.
- Apply threadlocker (e. g. Loctite® 243) to the fastening screws.
- ① Mount the gearbox so that the identification plate can still be read.
- ① The specified screw sizes and tightening torques can be found in Chapter 9.2 "Specifications for mounting to a machine".
- ① If your gearbox is equipped with a liquid-cooled adapter plate, the separate manual "Cooled adapter plate" (doc. no. 2022–D063351) applies for this. The manual will be provided by our Sales / Customer Service department on request. Please always provide the serial number.
- ① **WITTENSTEIN alpha GmbH** offers corresponding mounting kits for gearboxes in **Hygienic Design**. The separate instructions "Hygienic Design Instruction Sheet, Mounting Kit" (Doc. no. 2022–D062618) are valid for this. The manual will be provided by our Sales / Customer Service department on request. Please always provide the serial number.

5.3.1 Mounting with through-holes

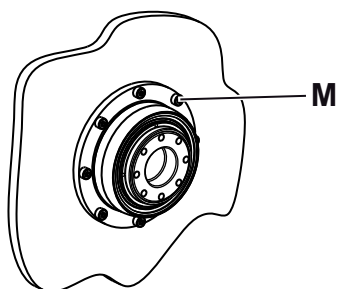

① If your gearbox is equipped with reverse centering for motor-side installation [M] on a machine, you will find more information in the separate manual "Reverse centering device for motor-side installation" (doc. no. 2022–D063062). The manual will be provided by our Sales / Customer Service department on request. Please always provide the serial number.

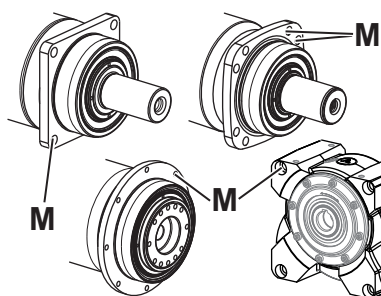

- ① We recommend doing without washers as long as the material of the screw surface features sufficient interface pressure.
- Fasten the gearbox on the machine with the fastening screws through the through-holes [M].

5.3.2 Mounting with slotted holes

- Use only the washers included with the delivery for fastening the gearbox to the machine (see Chapter 9.2 "Specifications for mounting to a machine").

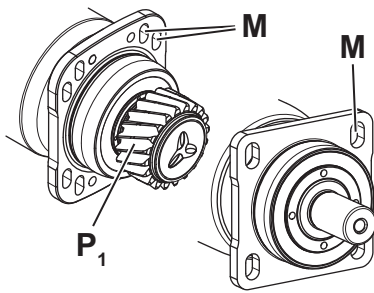

The gearbox can be optionally equipped with an output pinion [P₁]. The gearing backlash between output pinion and toothed rack/counter-wheel can be adjusted using the slotted holes [M] and the lateral guides. An additional adjustment mechanism is no longer necessary.

- ① Detailed information on the design of the gearbox interface is available on request.
- ① For the proper setting of the gearing backlash, you will find further information in the "alpha rack and pinion system" manual (doc. no. 2022-D001333). The manual will be provided by our Sales / Customer Service department on request. Please always provide the serial number.

Operating the gearbox without a motor (e.g. using a hand wheel) is permitted for setting / aligning the output pinion on the toothed rack.

- When doing so, ensure **never** to tilt / bend the clamping hub.

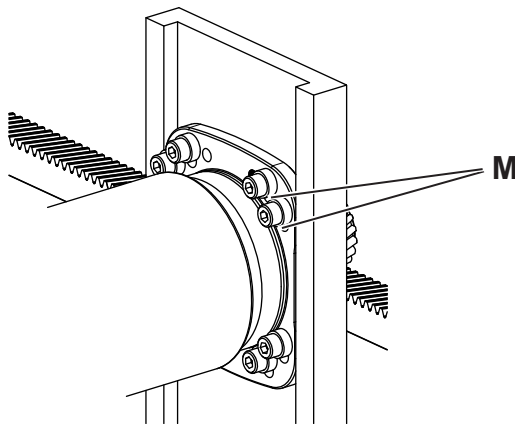

- Slide the washers onto the fastening screws.
- Fasten the gearbox to the machine with the fastening screws through the slotted holes [M].

Pinning the mounted and aligned gearbox (optional)

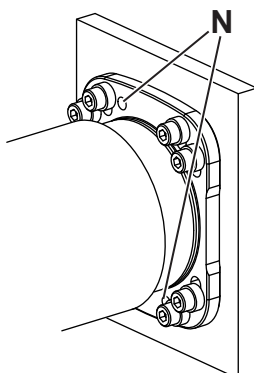

Optionally, there are two bore holes [N] on the gear housing for pinning the gearbox to the machine. You can fasten the gearbox to the machine with cylinder pins.

- Drill pin holes into the machine bed according to the bores [N] of the gear housing.
- Ream the bores to the corresponding fit size for the cylinder pins.
 - ① For specifications on the cylinder pins, refer to Chapter 9.2 "Specifications for mounting to a machine".
- Fasten the gearbox with the cylinder pins.

5.3.3 Mounting with threaded bores

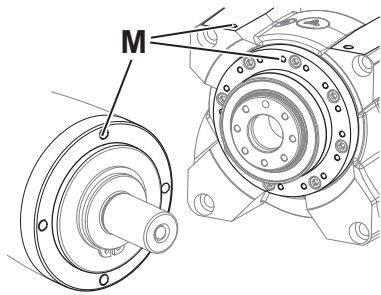

- ① We recommend doing without washers as long as the material of the screw surface features sufficient interface pressure.
- Fasten the gearbox to the machine with the fastening screws through the threaded bores [M].

5.4 Components mounted to the output side

The output side has different shapes depending on the product type:

- Smooth shaft
- Shaft with key
- Splined shaft (DIN 5480)
- Slip-on shaft / hollow shaft / hollow shaft interface / flange hollow shaft
- Flange
- with mounted output pinion
- For details on how to mount the **slip-on shaft / hollow shaft / hollow shaft interface**, refer to the instructions in Chapter 5.4.1 "Mounting with shrink disk".
- For details on how to fasten the **flange / flange hollow shaft / keyed hollow shaft**, refer to the instructions in Chapter 9.3 "Specifications for mounting to the output side".

	NOTICE
	<p>Tension during assembly may damage the gearbox.</p> <ul style="list-style-type: none"> ● Mount the mounting parts onto the output shaft / output flange without using force. ● Never attempt to assemble by force or hammering! ● Only use suitable tools and devices for assembly. ● Make sure not to exceed the maximum permissible static axial forces on the output bearing (see Chapter 9.3 "Specifications for mounting to the output side") when pulling or shrink-fitting a mounting part onto the output side.

- ① **WITTENSTEIN alpha GmbH** offers corresponding mounting kits for gearboxes in **Hygienic Design**. The separate instructions "Hygienic Design Instruction Sheet, Mounting Kit" (Doc. no. 2022–D062618) are valid for this. The manual will be provided by our Sales / Customer Service department on request. Please always provide the serial number.

5.4.1 Mounting with shrink disk

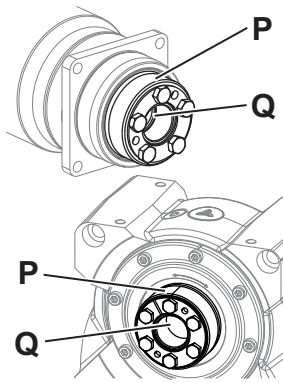

The slip-on shaft / hollow shaft / hollow shaft interface [Q] is axially secured to the load shaft by means of a shrink disk connection. If a gearbox with shrink disk [P] was ordered, then it is already mounted.

- If a different shrink disk is used, observe the instructions of the manufacturer.
- ① With the recommended fit size h6 for the load shaft, it must be possible to push the disk on without exerting force, but without a noticeable fit tolerance. The required dimensions for the slip-on shaft / hollow shaft / hollow shaft interface are found in the catalog (see also Chapter 3.4 "Dimensions and performance data").
- ① Further important instructions on how to handle the shrink disk are found in the separate manual "Shrink disk" (doc. no. 2022-D063039). The manual will be provided by our Sales / Customer Service department on request. Please always provide the serial number.

6 Startup and operation

- Read the general safety instructions before beginning to work (see Chapter 2.5 "General safety instructions").

Improper use can cause damage to the gearbox.

- Ensure that
 - the **ambient temperature** is in the permissible range (see Chapter 9.4 "Specifications for startup and operation") and
 - the **operating temperature** does not exceed +90 °C.
- Avoid freezing, which can damage the seals.
- Use the gearbox only in a clean, dust-free, and dry environment. Moisture penetration in the area of the drive in particular is inadmissible. In this connection, we recommend additional protection measures or alternative products.
- Only use the gearbox up to its maximum limit values, see Chapter 3.4 "Dimensions and performance data". For other conditions of use, consult our Customer Service department.

The following only applies to gearboxes with **food-grade lubricant**:

- The maximum permissible torques ($T_{2\alpha}$, T_{2B} , T_{2N}) may be reduced in comparison with standard gearboxes depending on the product type.
- For the maximum permissible torques observe the further information in Chapter 9.4 "Specifications for startup and operation".

The following only applies for **corrosion-resistant** gearboxes:

- The maximum permissible torques ($T_{2\alpha}$, T_{2B} , T_{2N}) may be reduced in comparison with standard gearboxes depending on the product type.
 - For the maximum permissible torques observe the further information in Chapter 9.4 "Specifications for startup and operation".
- The pump effect of a running gearbox can suck cleaning agents into the gearbox. The gearbox may only be cleaned when it is at standstill.
- To avoid corrosion, use only conventional cleaning agents that are grease-dissolving but not aggressive.
- High-pressured water jets can damage the gearbox seals and thus lead to leakage.
 - Never aim the water jet directly at the seals.
 - Attach a deflector in front of the seals if necessary.

Valid only for gearboxes in **Hygienic Design**:

- The pump effect of a running gearbox can suck cleaning agents into the gearbox. The gearbox may only be cleaned when it is at standstill.
- High-pressured water jets can damage the gearbox seals and thus lead to leakage.
 - Use a water jet with a **maximum** pressure of 28 bar.
- When a surface is roughened it cannot be cleaned without leaving traces.
 - Take care not to scratch the gearbox.
- Remove applied media from the sealing of the gearbox within 30 minutes.
- Use only cleaning processes as described in Chapter 9.4 "Specifications for startup and operation".

The following only applies to **servo worm gearboxes**:

- When using the gearbox in **continuous operation**, observe the further instructions given in Chapter 9.4 "Specifications for startup and operation".

7 Maintenance and disposal

- Read the general safety instructions before beginning to work (see Chapter 2.5 "General safety instructions").

7.1 Maintenance schedule

Maintenance work	At startup	For the first time after 500 operating hours or 3 months	Every 3 months
Visual inspection	X	X	X
Checking the tightening torques	X		

Tbl-10: Maintenance schedule

7.2 Maintenance work

7.2.1 Visual inspection

- Check the entire gearbox for exterior damage.
- Seals are subject to wear. Therefore also check the gearbox for leakage during each visual inspection.
 - ① Check the mounting position to ensure that no foreign medium (e.g. oil) has collected on the output shaft.
- The following only applies for **corrosion-resistant** gearboxes: Check the lacquer layer and the nickel-plated surfaces for damages and corrosion.

7.2.2 Checking the tightening torques

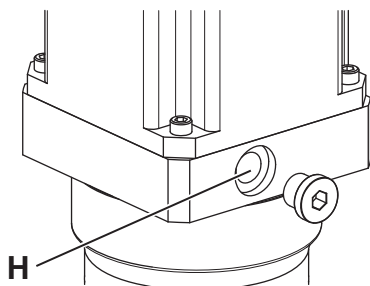

- Check the tightening torque of the clamping bolt [H] on the motor mounting. If, while checking the tightening torque, you discover that the clamping bolt can be turned further, tighten it to the prescribed tightening torque.
 - ① The value for the tightening torque can also be found in Chapter 9.1 "Specifications for mounting to a motor".

Screw connections between gearbox and attached component such as motors have to be calculated, dimensioned, mounted, and tested according to current technological standards. Use the VDI directives VDI 2862 sheet 2 and VDI 2230 for example.

- ① The tightening torques recommended by us can be found in Chapter 9 "Appendix".

Deviating from the recommendations in Chapter 5 "Assembly", washers may be used if the material of the screw surface features a too low interface pressure.

- ① The hardness of the washer needs to match the property class of the screw.
- ① Take into account the washer for the screw calculation (joint, additional compression set, surface pressure under screw head and under washer).

7.3 Startup after maintenance work

- Clean the outside of the gearbox.
- Attach all safety devices.
- Do a trial run before releasing the gearbox again for operation.

7.4 Disposal

Consult our Customer Service department for supplementary information on disassembly and disposal of the gearbox.

- Dispose of the gearbox at the recycling sites intended for this purpose.
 - ① Observe the applicable national regulations concerning disposal.

8 Malfunctions

	NOTICE
	<p>Changed operational behavior can be an indication of existing damage to the gearbox or can cause damage to the gearbox.</p> <ul style="list-style-type: none"> Do not put the gearbox back into operation until the cause of the malfunction has been rectified.

	<p>Rectifying of malfunctions may only be done by specially trained technicians.</p>
---	---

Fault	Possible cause	Solution
Increased operating temperature	The gearbox is not suited for the task.	Check the technical data.
	Motor is heating the gearbox.	Check the wiring of the motor.
		Ensure adequate cooling.
	Change the motor.	
	Ambient temperature too high.	Ensure adequate cooling.
Increased operating noises	Tension in motor mounting	Consult our Customer Service department.
	Damaged bearings	
	Damaged gear teeth	
Loss of lubricant	Excessive amount of lubricant	Wipe off discharged lubricant and continue to watch the gearbox. Lubricant discharge should stop after a short time.
	Only in the case of grease lubrication: "Seeping" at the output	in accordance with Chapter 5.1 "Preparations"
	Seals not tight	Consult our Customer Service department.

Tbl-11: Malfunctions

9 Appendix

9.1 Specifications for mounting to a motor

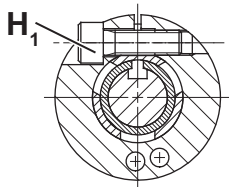
		Designation
	H ₁	Clamping bolt, eccentric

Tbl-12: Arrangement of motor shaft, clamping bolt and bushing

Tightening torque for clamping bolt (H ₁)					
Ordering code: xxxxxxxx-xxx-xxxxx-x(.)*x-xx (see Chapter 3.2 "Name plate")					
Clamping hub Ø ¹⁾ [mm]	(.) [*] Code letter	Width across flats [mm]	Tightening torque [Nm]		
			Coaxial	Angle	
				Coupling "K" ²⁾	Clamping hub socket "S" ²⁾
8	Z	2.5	2	—	—
9	A	2.5	2	—	—
11	B	3	4.1	—	4.1
14	C	4	9.5	8.5	9.5
16	D	5	14	14	—
19	E	5	14	14	14
24	G	6	35	35	35
28 ³⁾	H	5	14	—	—
28 ⁴⁾	H	6	—	35	—
32	I	8	79	69	—
38	K	8	79	69	79
48	M	10	135	86	135
55	N	10	135	—	—
60	O	14	330	—	—

¹⁾ The availability of particular clamping hub diameters can be found in the catalog.
²⁾ Ordering code:xxxx-xxx-xxxxx-xxx-x(.); Motor connection
³⁾ only applies for coaxial gearboxes
⁴⁾ only applies for angular gearboxes

Tbl-13: Specifications for clamping bolt, eccentric [H₁]

9.2 Specifications for mounting to a machine

The gearbox must only be operated in mounting position as specified in the order.

For further information on the mounting position, please refer to Chapter 9.4.1 "Mounting position".

9.2.1 Specifications for mounting with threaded holes

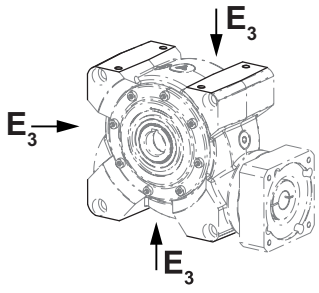
Gearbox size V-Drive	Quantity x thread x screw depth [] x [mm] x [mm]	Tightening torque [Nm] Property class 8.8	
	040	4 x M6 x 11.0	9.0
	050	4 x M8 x 13.5	21.5
	063	4 x M10 x 17.0	42.5
	080	4 x M12 x 19.5	73.5
	100	4 x M12 x 19.5	73.5
All threaded holes of a housing surface [E ₃] must be used for fastening at a machine.			

Tbl-14: Specifications for mounting to a machine

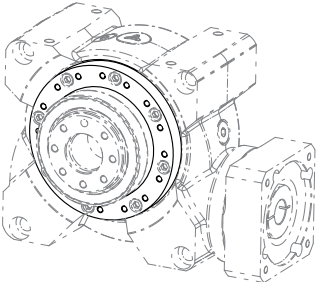
Gearbox size VT ⁺	Quantity x thread x screw depth [] x [mm] x [mm]	Tightening torque [Nm] Property class 10.9	
	050	16 x M5 x 8.5	7.6
	063	16 x M5 x 8.5	7.6
	080	24 x M6 x 12.0	13.2
	100	24 x M8 x 15.5	32.0

Tbl-15: Specifications for mounting to a machine VT⁺

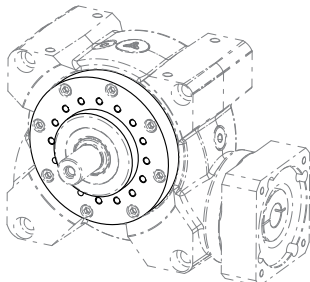
Gearbox size VS ⁺	Quantity x thread x screw depth [] x [mm] x [mm]	Tightening torque [Nm] Property class 10.9	
	050	16 x M6 x 10.0	13.2
	063	16 x M8 x 13.0	32.0
	080	24 x M10 x 15.0	62.5
	100	24 x M12 x 23.0	108

Tbl-16: Specifications for mounting to a machine VS⁺

9.2.2 Specifications for mounting with through-holes

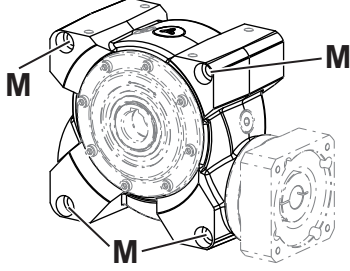
Gearbox size V-Drive		Screw size / Property class	Tightening torque [Nm]
	040	M8 / 8.8	21.5
	050	M10 / 8.8	42.5
	063	M10 / 8.8	42.5
	080	M10 / 8.8	42.5
	100	M12 / 8.8	73.5

Tbl-17: Specifications for mounting to a machine

9.3 Specifications for mounting to the output side

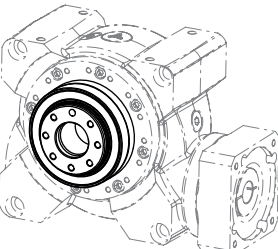
Gearbox size VT ⁺	Hole circle Ø [mm]	Quantity x thread x screw depth [] x [mm] x [mm]	Tightening torque [Nm] Property class 10.9	Indexing bore Ø *
	050	7 x M6 x 10	14	6 H 7
	063	11 x M6 x 12	14	6 H 7
	080	11 x M8 x 15	34	8 H 7
	100	11 x M10 x 20	67	10 H 7

The hollow shaft is **not** suitable for the transmission of force. Deformations or leakages can occur.

① Cables and rigid components may be routed through the hollow shaft but must not touch the inner diameter.

* For an indexing pin for mechanically zeroing the gearbox/the application.

Tbl-18: Thread in output flange VT⁺

Maximum permitted axial forces; $F_{a \max}$						
Product type / Ordering code		Gearbox size				
		040	050	063	80	100
VS⁺		–	10750	18500	31250	49750
NVS		6500	10750	18500	–	–
CVS	CVSxxxx-xFx-xxx-xxx-xx-xxx	2400	3000	4000	–	–
	CVSxxxx-xTx-xxx-xxx-xx-xxx	6500	10750	18500	–	–
Maximum permissible static axial forces at static structural safety (s_0) = 1.8 and radial force (RF) = 0						

Tbl-19: Maximum permitted axial forces

Further important instructions on how to handle the shrink disk are found in the separate manual "Shrink disk" (doc. no. 2022–D063039). The manual will be provided by our Sales / Customer Service department on request. Please always provide the serial number.

9.3.1 Mounting on the keyed hollow shaft

The shaft end (load shaft) of the machine must be equipped with a DIN 6885 Part 1, Form A shaft key and must have a DIN 332 Form DS centering (with thread) on the front side.

	NOTICE
	<p>Incorrectly aligned shafts can lead to damage.</p> <ul style="list-style-type: none"> • Check the hollow and load shafts for damaged edges or poor fit. Re-machine the components if necessary. • Ensure that the hollow shaft is aligned with the load shaft. • Mount the hollow shaft onto the load shaft without using force. • Never attempt to assemble by hammering or applying pressure.
	<p>Dirt can inhibit transmission of the torque.</p> <ul style="list-style-type: none"> • Clean/degrease the load shaft and the hollow shaft leaving no residual traces.
<ul style="list-style-type: none"> • Observe the safety and processing instructions of the lubricant used. 	

① Protect the cleaned fitting surfaces against fretting corrosion with a suitable lubricant (e.g. ALTEMP Q paste of Klüber Lubrication Deutschland SE & Co. KG).

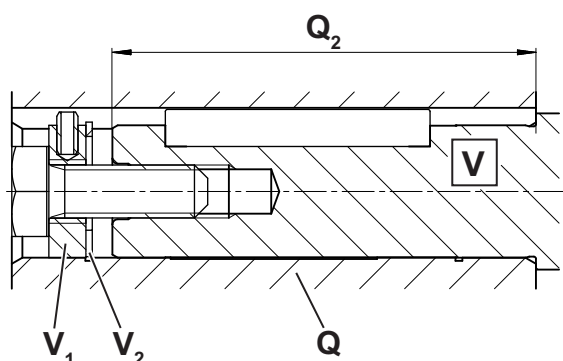

① The axial securing of the gearbox to the load shaft [V] can be made with an end washer [V₁] and a retaining ring [V₂].

① If the end washer is to be used for dismantling as a forcing washer, the load shaft [v] must not exceed a certain insertion length [Q₂] in the hollow shaft [Q]. For maximum insertion length see Table "Tbl-20".

Gearbox size VH ⁺ , NVH, CVH	040	050	063	080	100
maximum insertion length Q ₂ [mm]	64	77	89	119	159

Tbl-20: maximum insertion length load shaft

9.4 Specifications for startup and operation

Ambient temperature		
Product type	Minimum temperature [°C]	Maximum temperature [°C]
V-Drive	-15	+40

Tbl-21: Ambient temperature

<p>Ordering code: xxxxxxxF-xxx-xxxx-xxx-xx; Food-grade lubrication</p> <p>Ordering code: xxxxxxxW-xxx-xxxx-xxx-xx; Corrosion-resistant</p>
<p>With these gearboxes, the maximum permissible torques are not reduced.</p>

Tbl-22: Reduced torques

9.4.1 Mounting position

The gearbox must only be operated in mounting position as specified in the order.

① The mounting position can be found on the name plate (see Chapter 3.2 "Name plate").

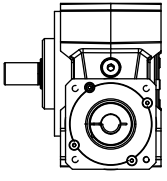
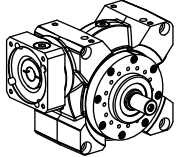
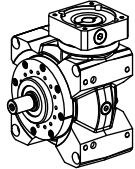
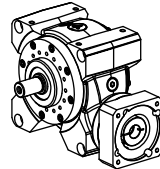
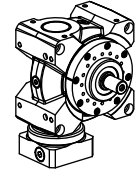
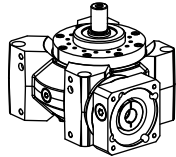
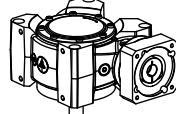
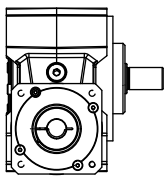
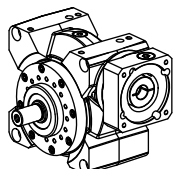
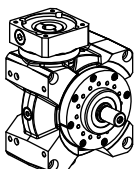
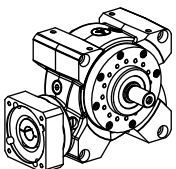
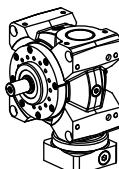
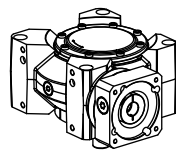
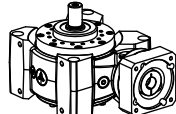
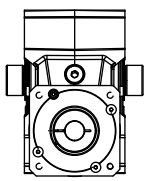
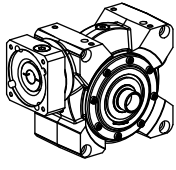
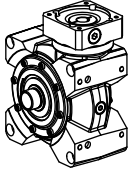
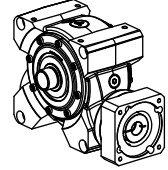
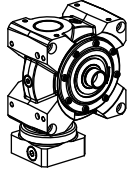
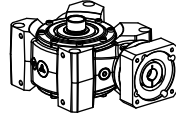
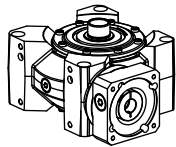
Output side	Ordering code: xxxxxxxx-xxx-xxx-xxx-xx-AXx				
A	AC	AF	AD	AG	AE
View of the motor connection, output left 					 
Output side	Ordering code: xxxxxxxx-xxx-xxx-xxx-xx-BXx				
B	BC	BF	BD	BG	BE
View of the motor connection, output right 					 
Output side	Ordering code: xxxxxxxx-xxx-xxx-xxx-xx-0Xx				
0 (A + B)	0C	0F	0D	0G	0E
with output shaft on both sides 					 

Tbl-23: Mounting position

9.4.2 Continuous operation

	<p>When using the gearbox in continuous operation (S1 operation), we recommend the use of a bleed screw.</p> <p>① The bleed screw is not included in the scope of delivery. WITTENSTEIN alpha GmbH offers suitable bleed screws to this end (see Table "Tbl-24"). If you would like to order a bleed screw, contact our sales department.</p>
--	--

Gearbox size V-Drive	040				050	063	080	100
Material number for bleed screw	20070677	20071468 (only with ordering code xxx040x-xxx-xxx-xx-XDx)			20070677			
Thread size	G1/4"	G3/8"			G1/4"			

Tbl-24: Bleed screw

9.5 Tightening torques for common thread sizes in general mechanical engineering

The specified tightening torques for headless screws and nuts are calculated values and are based on the following conditions:

- Calculation according to VDI 2230 (edition 11/2015)
- Friction value for thread and contact surfaces $\mu=0.10$
- Utilization of the yield stress 90%
- Torque tools type II classes A and D in accordance with ISO 6789

The settings are values rounded to usual commercial scale gradations or settings.

- Use the **exact** values in this table to set your tools.

Property class screw/nut	Tightening torque [Nm] with thread												
	M3	M4	M5	M6	M8	M10	M12	M14	M16	M18	M20	M22	M24
8.8 / 8	1.15	2.64	5.2	9.0	21.5	42.5	73.5	118	180	258	362	495	625
10.9 / 10	1.68	3.88	7.6	13.2	32.0	62.5	108	173	264	368	520	700	890
12.9 / 12	1.97	4.55	9.0	15.4	37.5	73.5	126	202	310	430	605	820	1040

Tbl-25: Tightening torques for set screws and nuts

Revision history

Revision	Date	Comment	Chapter
01	22.03.17	New version	All
02	02.05.17	Bleed screw	6
03	15.11.17	Bleed screw material number	6
04	06.12.17	Tightening torques	9.1
05	08.01.20	Layout	All



WITTENSTEIN alpha GmbH · Walter-Wittenstein-Straße 1 · 97999 Igersheim · Germany
Tel. +49 7931 493-0 · info@wittenstein.de

WITTENSTEIN – one with the future

www.wittenstein-alpha.de